



PARTS AND SERVICE MANUAL



V21 TRADE TABLE OF CONTENTS

SAFETY SECTION	Pages S-1 - S-16
A COMMITMENT TO SAFETY.....	Page S-2
VENDOR INSTALLATION.....	Pages S-3 - S-6
ELECTRICAL HAZARDS.....	Pages S-7 - S-8
MECHANICAL HAZARDS.....	Page S-9
REFRIGERATION HAZARDS.....	Page S-10
SUBSTITUTIONS AND MODIFICATIONS.....	Pages S-11 - S-12
CONSUMER SAFETY WARNING.....	Page S-13
PARTS, SALES, AND SERVICE CENTERS OF VENDO/SANDEN CO.....	Pages S-14 - S-15
GENERAL INFORMATION	Pages G1 - G12
GENERAL INFORMATION.....	Page G-2
INITIAL SET-UP.....	Pages G-3 - G-4
LABEL INSTALLATION.....	Page G-5
ALIGNMENT CHECKS.....	Page G-6
LOADING INSTRUCTIONS.....	Page G-6 - G-7
VEND MECHANISM PARTS DESCRIPTION.....	Pages G-8 - G-9
VEND CYCLE.....	Pages G-10 - G-11
PROGRAMMING SECTION	Pages PC-1 - PC-17
12.1 PROGRAMMING.....	Pages PC-2 - PC-3
SET-UP AND CODE DESCRIPTION.....	Pages PC-4 - PC-14
12.1 WIRING DIAGRAMS.....	Pages PC-15 - PC-16
TRADE CABINET SECTION	Pages C-1 - C-17
READING A PARTS LIST.....	Page C-2
HARDWARE LIST.....	Pages C-4 - C-5
CABINET ASSEMBLY.....	Pages C-6 - C-7
STACK ASSEMBLY.....	Pages C-8 - C-9
MECH PLATE ASSEMBLY.....	Pages C-10 - C-11
REFRIGERATION ASSEMBLY.....	Pages C-12 - C-13
POWER BOX ASSEMBLY.....	Pages C-14 - C-15
HARNESS QUICK REFERENCE GUIDE.....	Pages C-16
TRADE DOOR SECTION	Pages TD-1 - TD-14
OUTER DOOR.....	Pages TD-2 - TD-7
LOCK ASSEMBLY.....	Pages TD-8 - TD-9
SELECTION PANEL.....	Pages TD-10 - TD-11
INNER DOOR ASSEMBLY.....	Pages TD-12 - TD-13
MAINTENANCE	Pages M-1 - M-10
PREVENTATIVE MAINTENANCE SUGGESTIONS.....	Page M-2
LUBRICATION GUIDE.....	Page M-2
CARE AND CLEANING.....	Page M-3
REFRIGERATION OPERATION.....	Pages M-4 - M-6
REFRIGERATION PARTS DESCRIPTION.....	Pages M-7 - M-9



TROUBLESHOOTING	Pages T-1 - T-12
VENDO WARRANTY	Pages T-2
PARTS RETURN PROCEDURE	Page T-3
TROUBLESHOOTING GUIDE	Pages T-4 - T-11



SAFETY SECTION



A COMMITMENT TO SAFETY

The Vendo Company is committed to safety in every aspect of our product design. Vendo is committed to alerting every user to the possible dangers involved in improper handling or maintenance of our equipment. The servicing of any electrical or mechanical device involves **potential hazards**, both to those servicing the equipment and to users of the equipment. These hazards can arise because of improper maintenance techniques. The purpose of this manual is to alert everyone servicing Vendo equipment of potentially hazardous areas, and to provide **basic safety guidelines** for proper maintenance.

This manual contains various **warnings** that should be carefully read to minimize the risk of personal injury to service personnel. This manual also contains service information to insure that proper methods are followed to avoid damaging the vendor or making it unsafe. It is also important to understand these **warnings** are not exhaustive. Vendo could not possibly know, evaluate, or advise of all of the conceivable ways in which service might be done. Nor can Vendo predict all of the possible hazardous results. The safety precautions outlined in this manual provide the basis for an effective safety program. Use these precautions, along with the service manual, when installing or servicing the vendor.

We strongly recommend a similar commitment to safety by every servicing organization. Only **properly-trained personnel should have access to the interior of the machine**. This will minimize the potential hazards that are inherent in electrical and mechanical devices. Vendo has no control over the machine once it leaves the premises. It is the owner or lessor's responsibility to maintain the vendor in a safe condition. See Section I of this manual for proper installation procedures and refer to the appropriate service manual for recommended maintenance procedures. If you have any questions, please contact the Technical Services Department of the Vendo office nearest you.

SAFETY RULES

- Read the Safety Manual before installation or service.
- Test for proper grounding before installing to reduce the risk of electrical shock and fire.
- Turn off power switch or disconnect power cord from wall outlet before servicing or clearing product jams. The vending mechanism can trap and pinch hands.
- Use only fully-trained service technicians for Power-On servicing.
- Remove any product prior to moving a vendor.
- Use adequate equipment when moving a vendor.
- Always wear eye protection, and protect your hands, face, and body when working near the refrigeration system.
- Use only authorized replacement parts.
- Be aware of inherent dangers in rocking or tipping a vending machine.
- Always turn power off before plugging or unplugging vendor to wall outlet.



SECTION I: VENDOR INSTALLATION

- A. Vendors are large, bulky machines of significant size and weight. Improper handling can result in injury. When moving a vendor, carefully plan the route to be taken and the people and equipment required to accomplish the task safely.
- B. Remove all tape, shipping sealant, and Styrofoam from the vendor. Loosen any shipping devices used to secure interior parts during shipping. Remove the wooden shipping base attached to the vendor base by the vendor leveling screws. Make certain the leveling screws are in place and functional.
- C. Position the vendor three to four inches (7.6 cm to 10.2 cm) from a well-constructed wall (of a building or otherwise) on a flat, smooth surface.

IMPORTANT: *The vendor requires three inches (7.6 cm) of air space from the wall to ensure proper air circulation to cool the refrigeration unit.*

- D. Adjust the leveling screws to compensate for any irregularities on the floor surface. Ideally, no adjustment will be necessary and the leveling legs will be flush with the bottom of the vendor. A spirit level is a useful aid to level the vendor. When the outer door is open, it will remain stationary if the vendor is properly leveled. Vendors must be level to ensure proper operation and to maintain stability characteristics. Do not add legs to the vendor. **The leveling legs shall not raise the vendor more than 1 1/8 inch above the ground.**
- E. Check the manufacturer's nameplate on the left or right side of the vendor's outer door to verify the main power supply requirements of the vendor. Be sure the main power supply matches the requirements of the vendor. To ensure safe operation, plug the vendor only into a properly grounded outlet.
DO NOT USE EXTENSION CORDS.
- F. Recommended voltage specs = volts required + amps of circuit.

NOTE: Any power supply variance more than $\pm 10\%$ may cause the vendor to malfunction.

- * Power outlets must be properly **grounded**.
- * Power outlets must be properly **polarized**, where applicable.

Test the outlets using the following information.
(Refer to Figure 1 on Page S-4.)

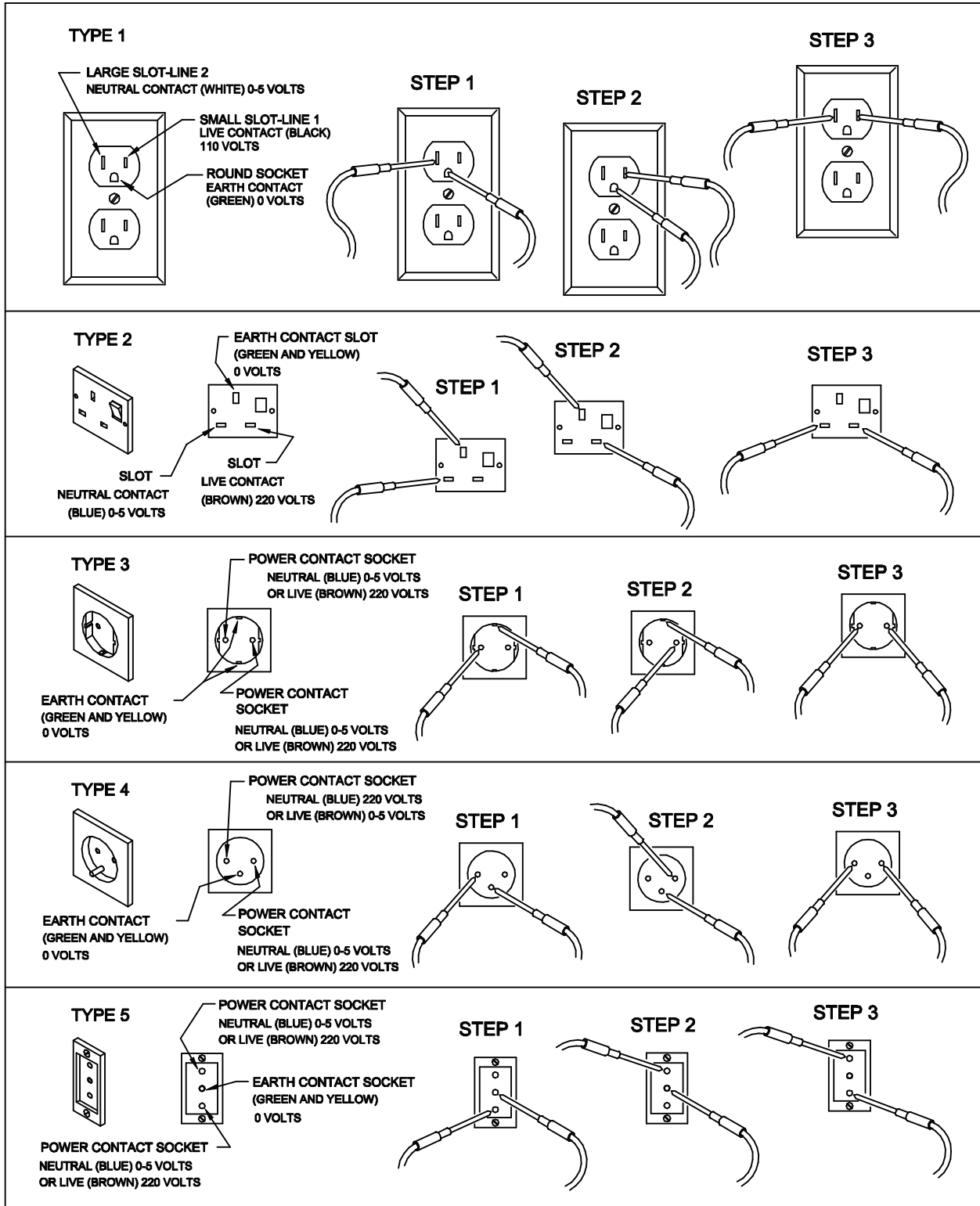



SECTION I: VENDOR INSTALLATION (CONTINUED)

For Type 1 and Type 2 outlets, test for Grounding and Polarization as follows:

1. With a test device (volt meter or test light), connect one probe to the receptacle's neutral contact and the other to the live contact. The test device should show a reaction.
2. Connect one probe to the receptacle's earth contact and the other to the live contact. The test device should show a reaction.

For Type 3 through Type 5 outlets, test for Grounding as follows:

1. With a test device (volt meter or test light), determine which of the receptacle's power contacts is the live contact.
 - A. Connect one probe to the receptacle's earth contact.
 - B. Connect the second probe to the left (or upper) power contact. If a reaction occurs, this is the live power contact. If a reaction does not occur, move the second probe to the right (or lower) contact. A reaction should occur, indicating that this is the live power contact.
2. Connect one probe to the receptacle's live power contact (as determined in step 1). Connect the second probe to the other power contact (neutral). The test device should show a reaction.

IF THE ABOVE CONDITIONS ARE NOT MET FOR THE GIVEN OUTLET TYPE, CONTACT A LICENSED ELECTRICIAN AND HAVE THE NECESSARY CORRECTIONS MADE.



SECTION I: VENDOR INSTALLATION (CONTINUED)

G. Door Support (Figure 2)

The door support is to ensure that the outer door closes squarely to the cabinet. Raising the door can also ensure proper alignment of the door latch.

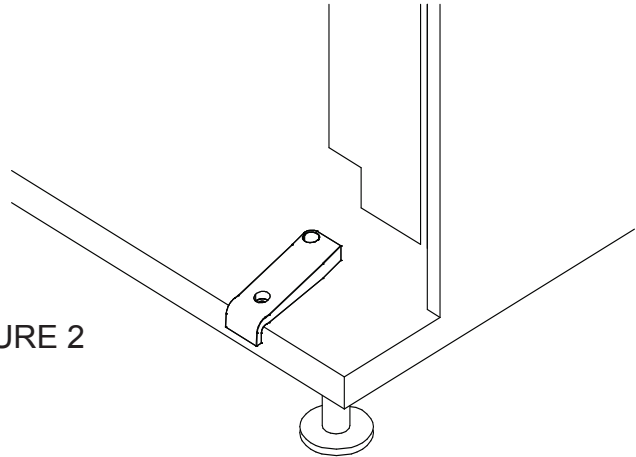

FIGURE 2

H. Door Latch Alignment (Figure 3)

After any door adjustment, the floating quicker lock assembly should align itself automatically. The latch assembly is adjustable. To adjust, loosen the latch bracket mounting screws, raise or lower the latch assembly into position, then tighten the mounting screws.

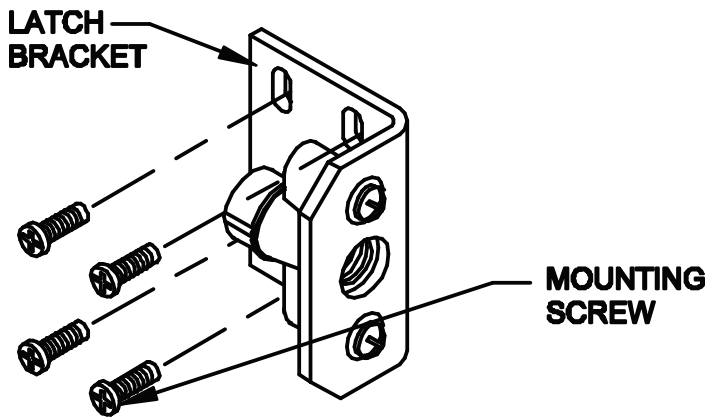
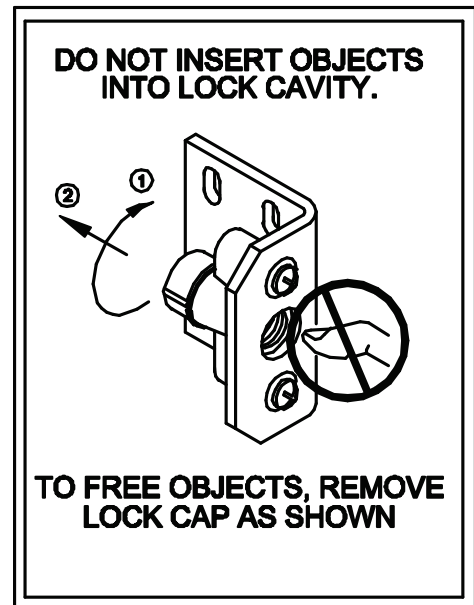

FIGURE 3



WARNING:
KEEP FINGERS AND OTHER OBJECTS OUT OF LOCK CAVITY

NOTE: Refer to the appropriate parts and service manual for detailed instructions, operating principles, and recommended maintenance intervals and procedures.



SECTION II: ELECTRICAL HAZARDS

GENERAL

Vendo vending machines are provided with the appropriate power supply setting for your area. Some models are equipped with step-down transformers, as required. This enables the vending machine to operate on different main voltages. Refer to Section I. E. for information to determine the main power requirements. Refer to the appropriate service manual for details of step-down transformer operations.

The power sources just mentioned are standard for both household and commercial lighting and appliances. However, careless or improper handling of electrical circuits can result in injury or death. Anyone installing, repairing, loading, opening, or otherwise servicing a vending machine should be alerted to this point. Apply all of the normal precautions observed in handling electrical circuits, such as:

- Refrigeration servicing to be performed by qualified personnel only.
- Unplug the vendor or move power switch to off position before servicing or clearing product jams.
- Replace electrical cords if there is any evidence of fraying or other damage.
- Keep all protective covers and ground wires in place.
- Plug equipment into outlets that are properly grounded and polarized (where applicable), and protected with fuses or circuit breakers.
- All electrical connections must be dry and free of moisture before applying power.

A. Grounding Systems

Vendo vending machines are provided with the appropriate service cord for the power supply in your area. The service cord will connect to the matching electrical outlet. Always ensure that the outlet to be used is properly grounded before plugging in the vendor. (See pages S-3 through S-5.)

WARNING:
**ALWAYS TEST TO VERIFY PROPER GROUNDING PRIOR TO
INSTALLATION TO REDUCE THE RISK OF ELECTRICAL
SHOCK AND FIRE**

The electrical grounding system also includes the bonding of all metal components within the vendor. This involves a system of bonding wires identified by green or green and yellow marking. The system uses serrated head screws, lock washers, and star washers to ensure the electrical connection between parts. Maintenance of vending equipment may involve disassembly. Include the above items when reassembling, even if the vending machine may appear to function normally without them. Omitting any of these items can compromise a link in the grounding system. See the appropriate service manual or kit instructions for components and assembly instructions.



SECTION II: ELECTRICAL HAZARDS (CONTINUED)

B. Servicing with “Power Off”

For maximum safety, unplug the service cord from the wall outlet before opening the vendor door. This will remove power from the equipment and avoid electrical and mechanical hazards. Service personnel should remain aware of possible hazards from hot components even though electrical power is off. See the appropriate sections of this manual for further information.

C. Servicing with “Power On”

Some service situations may require access with the power on. Power on servicing should be performed **only by fully-qualified service technicians**. Particular caution is required in servicing assemblies that combine electrical power and mechanical movement. Sudden movement (to escape mechanical action) can result in contact with live circuits and vice versa. It is therefore doubly important to maintain maximum clearances from both moving parts and live circuits when servicing.

WARNING:
“POWER ON” SERVICING SHOULD BE ACCOMPLISHED ONLY BY FULLY-TRAINED PERSONNEL. SUCH SERVICE BY UNQUALIFIED INDIVIDUALS CAN BE DANGEROUS.

Power to lighting and refrigeration system is shut off automatically by the electronic controller when the outer door is opened.

NOTE: For power-on servicing of the vendor’s lighting system, turn lighting power on by accessing the Lights test function of the electronic controller (see programming on inner door).

For power-on servicing of the vendor’s refrigeration system, turn refrigeration power on by accessing the Compressor test function of the electronic controller (see programming on inner door).



SECTION III: MECHANICAL HAZARDS

A. Servicing of Moving Parts and Assemblies

When servicing assemblies involving moving parts, **use extreme caution!!** Keep fingers, hands, loose clothing, hair, tools, or any foreign material clear of entrapment.

As noted before under the electrical hazards section, Power On servicing should **only** be performed by qualified personnel. Refer to and heed the warnings noted in the electrical hazards section. These warnings refer to the potential hazards associated with electrical power and moving parts. Always maintain maximum clearances from electrical and moving parts.

Always install protective covers and guards when reassembling equipment.

WARNING:
THIS VENDING MACHINE INCLUDES MECHANICAL EQUIPMENT WHICH CAN BE HAZARDOUS IF IMPROPERLY HANDLED OR SERVICED. USE CAUTION AND CONSULT THE VENDO SAFETY MANUAL AND VENDO SERVICE MANUAL FOR ADDITIONAL SAFETY INFORMATION.





SECTION IV: REFRIGERATION HAZARDS

GENERAL

Refrigeration systems involve both electrical power and mechanical action. These systems may present any of the potential dangers shown in the sections on electrical and mechanical hazards contained in this manual. See Sections II and III for further information.

A. Compressed Refrigerant

Refrigeration systems involve the compression and evaporation of gases. The pressures contained represent a potential hazard if suddenly released in confined areas. Caution is required when performing maintenance tests or repairs. All testing of sealed refrigeration systems must be done by trained personnel who are familiar with the systems and pressures involved.

B. Physical Protection

The accidental release of refrigerant gases can result in physical injuries. Always wear protective glasses and protect your hands, face, and body when working near the refrigeration system.

WARNING:
**ALWAYS WEAR EYE PROTECTION AND PROTECT YOUR HANDS,
FACE, AND BODY WHEN WORKING NEAR THE REFRIGERATION
SYSTEM**

SECTION V: TEMPERATURE HAZARDS

GENERAL

Maintenance personnel should be alerted to the potential hazards from hot metal surfaces. High temperatures may be present throughout the refrigeration system even though electrical power has been removed.



SECTION V: SUBSTITUTIONS AND MODIFICATIONS

GENERAL

Unauthorized changes or the substitution of unauthorized parts can compromise the equipment designs. This can result in unsafe conditions for either the service personnel or the equipment users. Always refer to the appropriate parts and service manual for replacement parts and maintenance instructions. If questions arise, contact the Technical Services Department of the Vendo office in your area.

When servicing the vending machine, always reassemble all components to their original location and position. Maintain the correct routing for tubing, electrical wiring, etc.. Replace all clamps, brackets, and guides to their original locations. Replace all tubing, sleeving, insulating material, and protective covers to their original condition

WARNING:

VENDO EQUIPMENT HAS BEEN PROVIDED WITH APPROPRIATE PROTECTIVE DEVICES TO PROTECT AGAINST THE POSSIBILITY OF OVERHEATING AND FIRE AS A RESULT OF EQUIPMENT OR COMPONENT FAILURES. SUBSTITUTION, MODIFICATION, OR BYPASSING OF SUCH PROTECTIVE DEVICES CAN CREATE DANGEROUS CONDITIONS. PROTECTIVE CIRCUITS SHOULD NEVER BE BYPASSED, AND FAILED PROTECTIVE DEVICES MUST BE REPLACED ONLY WITH FACTORY-AUTHORIZED PARTS.

A. Service Cord Replacement

Vendo vending machines are furnished with unique power supply cords. If replacement becomes necessary, consult the appropriate parts and service manual and order the correct replacement cord for the model of vending machine in question. Do not use substitute replacement cords. Only authorized service personnel with appropriate training should replace the vending machine service cord. If a question should arise concerning which service cord to order, contact the Technical Services Department of the Vendo office in your area.



SECTION V: SUBSTITUTIONS AND MODIFICATIONS (CONTINUED)

WARNING:
THIS APPLIANCE MUST BE EARTHED.
IMPORTANT!

The wires in the main leads are colored in accordance with the following code:

110v/120v	220v/240v	
Green	Green and Yellow	Earth
White	Blue	Neutral
Black	Brown.....	Live



SECTION VI: CONSUMER SAFETY WARNING

WARNING:
VENDOR CAN BE OVERTURNED IF SUFFICIENT FORCE IS APPLIED AND MAY RESULT IN SERIOUS INJURY OR DEATH.

GENERAL

There have been incidents, including fatalities, when vending machines have been vandalized by being pulled over in an attempt to obtain free product or money.

To warn of the danger involved in tipping, shaking, or rocking the vending machine, a decal has been designed to be affixed to vending machines. (One such decal is applied on the vending machine.) Vendo will supply sufficient decals to be placed on all machines, on request. If you have any questions, contact the Technical Services Department of the Vendo office in your area.

THE FOLLOWING DECAL SHOULD BE PLACED IN A POSITION ON THE VENDOR CONTROL PANEL AT EYE LEVEL

⚠ WARNING



Never rock or tilt. Machine can fall over and cause serious injury or death.

Vending machine will not dispense free product.

389611

ENGLISH

⚠ MISE EN GARDE



Ne jamais secouer ou incliner. Le distributeur peut se renverser et causer des blessures graves ou la mort. Cette machine ne distribue pas de produits gratuitement.

389611-1

FRENCH

⚠ AVISO



Nunca inclinar o balancear la máquina. La máquina puede caer y causar serios daños, incluso muerte. Esta máquina no dispensa producto gratis.

389611-2

SPANISH



AREA	ADDRESS	PHONE NUMBERS
United States, Canada	The Vendo Company 7209 N. Ingram Fresno, CA 93650 U.S.A.	Tel: (559) 439-1770 Fax: (559) 439-2083
Japan	Sanden International Corporation 31-7 Taito 1-Chome Taito-ku Tokyo 110, Japan	Tel: (81) 3-3835-1321 Fax: (81) 3-3833-7096
Europe, Mid-East Africa, Mid-Asia	Vendo GMBH Spangerstr. 22, P.O. Box 130940 40599 Dusseldorf Germany	Tel: (49) 211-74-039-0 Fax: (49) 211-7488541
Australia, New Zealand	Sanden International Pty. Ltd. 54 Allingham St., Condell Park N.S.W. 2200 Australia	Tel: 61-2-9791-0999 Fax: 61-2-9791-9029
Singapore, Hong Kong, Indonesia, Phillippines, India	Sanden International (Singapore) Pte., Ltd. Sanden House, 25, Ang Mo Kio St. 65 Singapore 569062 The Republic of Singapore	Tel: 65-482-5500 Fax: 65-482-1697
Taiwan	Sanden International Taiwan Corp. No, 21-6, Sec 1 Tun Hwa S. Rd., Taipei, Taiwan Taiwan, ROC	Tel: 886-2-570-6106 Fax: 886-2-577-1959
Belgium	N.V. Vendo Benelux, S.A. Industrial Research Park N.O.H. 13 Font St. Landry 1120 Brussels Belgium	Tel: 32-2-268-2595 Fax: 32-2-268-2862
England	Vendhall, Ltd. Unit 17, The Basingstoke Enterprise Centre Westham Lane, Worting Rd, Basingstoke, Hants RG22, 6NQ Great Britain	Tel: 44-1256-479309 Fax: 44-1256-844469
Italy	Vendo Italy S.p.A. Casella Postale 9 1-15033 Casale Monferrato Italy	Tel: 39-142-335111 Fax: 39-142-5623-48
Spain	Vendo Iberia, S.A. C/ Sant Ferran No. 92 Poligono Industrial la Almeda, Sector P-1 08940 Cornellà, (Barcelona), Spain	Tel: 343-474-1555 Fax: 343-474-1842



AREA	ADDRESS	PHONE NUMBERS
Mexico	Vendo de Mexico Camino Real de Toluca No. 154 Col. Bellavista 01140 Mexico D.F. Mexico	Tel: (525) 515-9745 Fax: (525) 277-0111
Central America	The Vendo Company 7209 N. Ingram Fresno, CA 93650 U.S.A.	Tel: (559) 439-1770 Fax: (559) 439-2083
Chile	Pelp Internacional, S.A. 4560 El Rosal Huechuraba, Santiago, Chile	Tel: (562) 243-9710 Fax: (562) 740-0504
Brazil	Cimaq Industria e Comercio de Maq, Ltda. Estrada Uniao e Industria, 9.120 Itaipava 25730-730 Petropolis Rio de Janeiro, Brazil	Tel: (55242) 22-2666 Fax: (55242) 22-3244
South America	The Vendo Company 7209 N. Ingram Ave. Fresno, CA 93650 U.S.A.	Tel: (559) 439-1770 Fax: (559) 439-2083



NOTES



GENERAL INFORMATION SECTION



GENERAL INFORMATION

This manual contains programming, operation, and complete parts and electrical wiring diagrams.

The V21 controller is a microprocessor which will permit pricing per selection from 0.00 to 99.99. This machine also has space-to-sales programming as well as energy savings modes.

MODEL		V21 621	V21 721	V21 821
SELECTIONS		7-8	9-10	9-10
DIMENSIONS (HEIGHT X WIDTH X DEPTH)				
CURVED DOOR		72" x 32 1/2" x 34 3/4"	72" x 39 1/2" x 35"	79" x 39 1/2" x 35"
SINGLE COLUMNS		7-8	9-10	9-10
CAPACITY PER COLUMN	12 oz. CAN***	68	68	80
	16 oz. GLASS	28	28	34
	20 oz. **	30	30	36
SHIPPING WEIGHT		640 lbs	685 lbs	750 lbs
OPERATION VOTAGE		115V 60Hz.	115V 60Hz.	115V 60Hz.
AMP. RATING		10	10	10
REFRIGERATION VOLTAGE		115V 60Hz.	115V 60Hz.	115V 60Hz.

*Dimensions and shipping weight will vary slightly due to manufacturing tolerances, shipping boards and whether or not coinage is installed.

** 20 oz. PET capacity may vary based on the shape and size of the bottle.

***12 oz. can capacities are listed using a 4-deep set up.



INITIAL SET-UP

A. UNPACKING

Remove all plastic film, cardboard and tape from the outside of the vendor. Loosen any shipping devices used to secure interior parts during shipment (backspacer, shims or spacers).

To remove shipping boards from base, raise vendor on a well-stabilized lifting device. Remove the leveling bolts which hold the boards in place and remove the boards. Replace bolts to equal heights in the threaded holes. Another method to remove shipping boards is to split the boards apart. Using a pinch bar or a heavy screwdriver and hammer, insert tool into the slots and force the boards apart. **The leveling legs shall not raise the vendor more than 1 1/8 inch above the ground.**

B. POSITIONING

IMPORTANT: PLACE THE VENDOR IN DESIRED LOCATION AT LEAST THREE TO FOUR INCHES (7.6CM TO 10.2CM) AWAY FROM ANY REAR OBSTRUCTION. This is for proper air flow through the refrigeration compartment. The refrigeration system requires rear to front air circulation for proper operation.

C. POWER SUPPLY CONNECTION

CAUTION: DO NOT USE AN EXTENSION CORD!

The vendor's power requirements will vary depending upon the country it was purchased for. To verify the power requirements of the vendor, check the serial plate located on the hinged side of the outer door (see Figure 4 on page G-4). The power requirements are listed on the serial plate.

To insure safe operation of the vendor, the vendor's power supply must be a properly grounded and polarized outlet. Before plugging the vendor into the outlet, test the outlet to confirm it will meet the vendor's power requirements. If the power supply of the outlet is different from the power requirements of the vendor, a transformer may be necessary.

If the power requirements are not properly met, contact a licensed electrician and have the necessary correction made.

Should you require additional information, contact the Technical Services Department of the Vendo office in your area.



APPROVED FOR OUTDOOR USE

MODEL **BASIC UNIT**

SERIAL NO.

CHARGE **OZ. R-134a**

DESIGN PRESSURE - PSig
LOW SIDE 90 HIGH SIDE 295

 **REFRIGERATED VENDING MACHINE 239L**

AMPS

VOLTS
 CYCLE
 PHASE

 **MFD IN U.S.A. BY THE VENDO CO., FRESNO, CA.**

POWER REQUIREMENTS 

FIGURE 1

NOTE: The **Model** number of the vending machine is located on the top, left hand corner of the serial plate. **Do Not use the "BASIC UNIT" number.** The BASIC UNIT number is the cabinet size, which is used on a number of different machines. A typical model number could read "721TDD00029". The 721 is the model number, TDD represents the product line of the vendor, and the remaining digits tell what options are included.

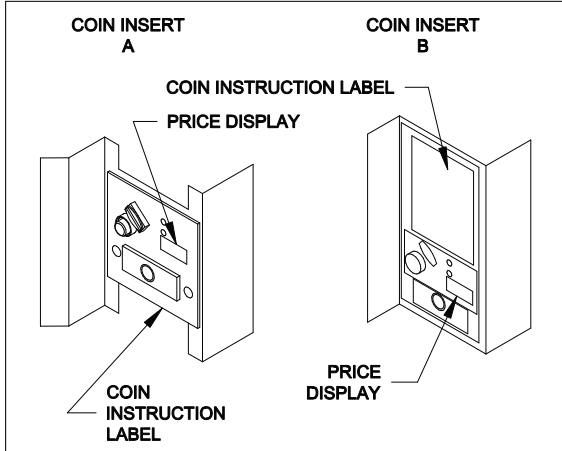

FIGURE 2

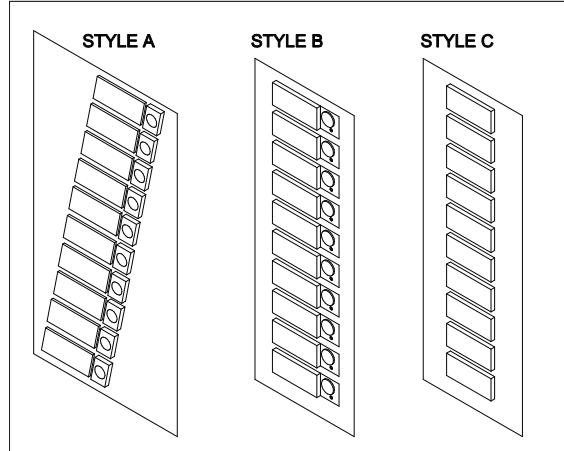

FIGURE 3

LABEL INSTALLATION

COIN INSTRUCTION LABEL & PRICE LABEL APPLICATION:

Apply labels to a clean and dry surface. Peel backing from label and apply with firm, even pressure.

INSTRUCTION LABEL

(Refer to Figure 2 for the following information.)

Coin insert “A” has a separate validator opening, and insert “B” shows the validator opening built into the coin insert. Apply instruction label to area shown (as needed by the vendor).

FLAVOR LABELS INSTALLATION:

In Figures 3 & 4, corresponding styles are indicated by A, B, C, D, or E notations.

Insert flavor labels to the side or top of selection window or button depending on the style. See Figure 3 for selection style. Rear views of windows and buttons are shown in Figure 4. Arrows point the direction to insert labels.

Selection window and selection button labels identify product contained in columns.

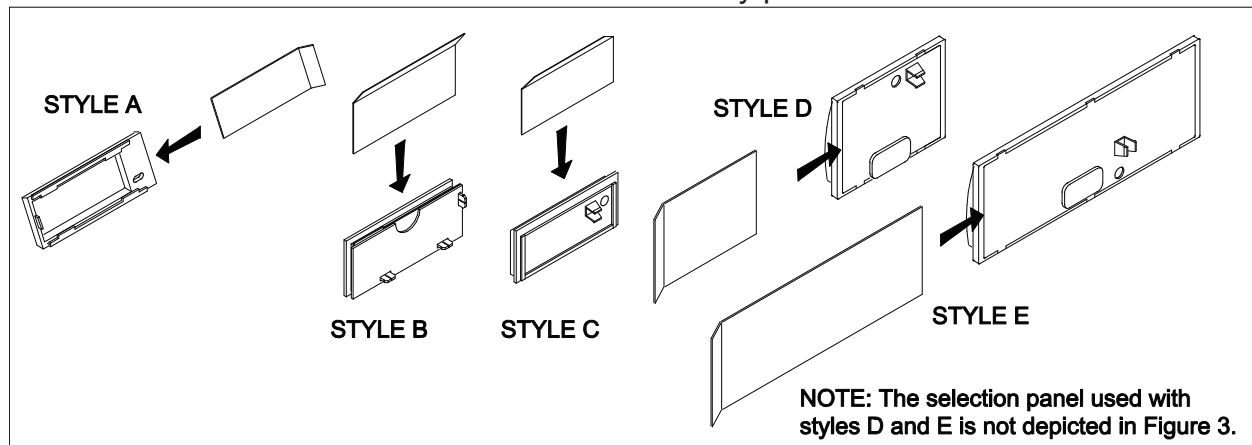

FIGURE 4

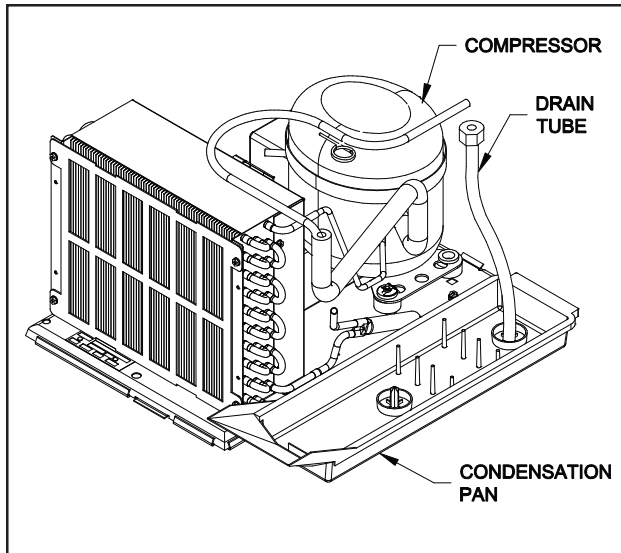

FIGURE 5

ALIGNMENT CHECKS

REFRIGERATION AREA CHECK:

Check the position of the condensation pan (see Figure 5). The correct position of the pan is on the right hand side of the vendor with the ramp of the pan just outside the right hand air dam. Be sure the drain tube is attached to the pan and is free of kinks. A water trap is installed into the condensation pan and will prevent warm, moist air from reaching the evaporator area.

LOADING INSTRUCTIONS

BASIC LOAD SET-UP (see Figure 6 on next page):

The V21 machine is capable of vending a variety of products. For specific information, refer to the product set-up label on the machine inner door or contact the Technical Services Department of the Vendo office in your area.

Load product evenly. Product is to be loaded differently depending on the type of product being vended. Use the directions in Figure 6 in the **PRODUCT LOADING** section to determine how to load a specific product.

To maintain the integrity of the stack, never move a vending machine when it is loaded.



V21 PRODUCT SETUP AND LOADING INSTRUCTIONS

FOLLOW THE 3 STEPS BELOW WHEN SETTING VENDOR UP FOR A PRODUCT

1

BACK SPACER

Adjust the back spacer to provide approx. 1/4" to 1/2" gap between the front spacer, product and back spacer.

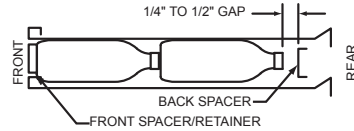

2

PRODUCT STEP

For short product vending, move the product step to the "FORWARD" position.
For tall product vending, move the product step to the "BACK" position.

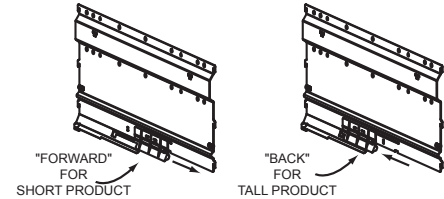

3

DEPTH SETTING (ELECTRONIC CONTROL MODE)

The "DEPTH SETTING" for each column must correspond to the number of products in the column. For example; the depth setting for a column vending double depth bottles must be set to "2", and a column set to vend quadruple depth cans must be set to "4".

Refer to the VEC 12 programming instructions for details on how to access and change the depth setting mode.

- 4 Deep: Cans between 4.50" and 4.85" tall.
- 3 Deep: Bottles or cans between 4.85" and 6.50" tall.
- 2 Deep: Bottles between 6.50" and 9.95" tall.
- 1 Deep: Bottles taller than 9.95".

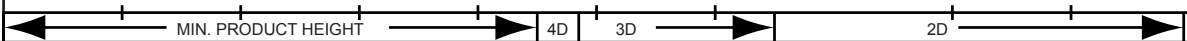

PRODUCT LOADING

- Single depth bottles should be loaded with cap toward the back.
- Double depth bottles may be loaded with caps toward the back, or butt to butt.
- Triple depth bottles must be loaded with caps toward the back.
- Quadruple depth cans may be loaded any direction.

FRONT
VENDOR

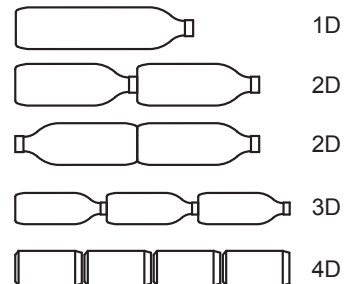

SMALL DIAMETER PRODUCT SETTING

- Small diameter products (less than 2.5" Ø) such as 500 ML water bottles require the use of side spacer PN 1122928.

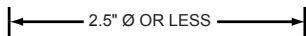

- Small diameter 250 ML energy drink cans (2.1" Ø) require the use of conversion kit PN 1121638.

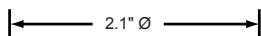

NOTES

- Side spacers **ARE NOT** required for 12 oz. can vending.
- Vend mechanism is self priming. No need to manually prime after initial load or reload.
- For questions regarding product settings, contact the Vendo Technical Services Department at 1-800-344-7216 ext.3368 (US/Canada) or 559-439-1770 ext.3368.

1124035

FIGURE 6



VEND MECHANISM PARTS DESCRIPTION

The parts listed below are part of the vend motor mechanism (refer to Figure 7 on page G-9). One mechanism is required per column. The parts are interchangeable. Setting will differ between single, double, triple, and quadruple depth.

VEND MOTOR ASSEMBLY: P/N 1122820

The motor is attached to the mech plate by two screws.

VEND BUCKET: P/N 1122815

The vend bucket holds the product(s) in a “ready to vend” position at the base of each column.

MOTOR COUPLING CAM: P/N 1122817

The coupling cam couples the motor to the bucket. It is located behind the motor, on the motor shaft. It is also a means to provide feedback to the controller to determine when the motor has reached maximum clockwise and counterclockwise positions.

GATE: P/N 1122871

The gate holds product above the vend bucket.

GATE LINK: P/N 1122819

The rotation of the coupling cam moves the gate link. This opens the gate, allowing one layer of product to drop into the bucket.

CAN STEP: P/N 1122856

The can step is located at the bottom of the stack partition. It is pulled forward when vending cans and is moved back for bottle vending.

REAR BUSHING: P/N 1122816

The rear bushing provides a low friction pivot for the rear of the bucket.

FRONT SPACER: P/N 1122814

The front spacer helps to guide product into the bucket.

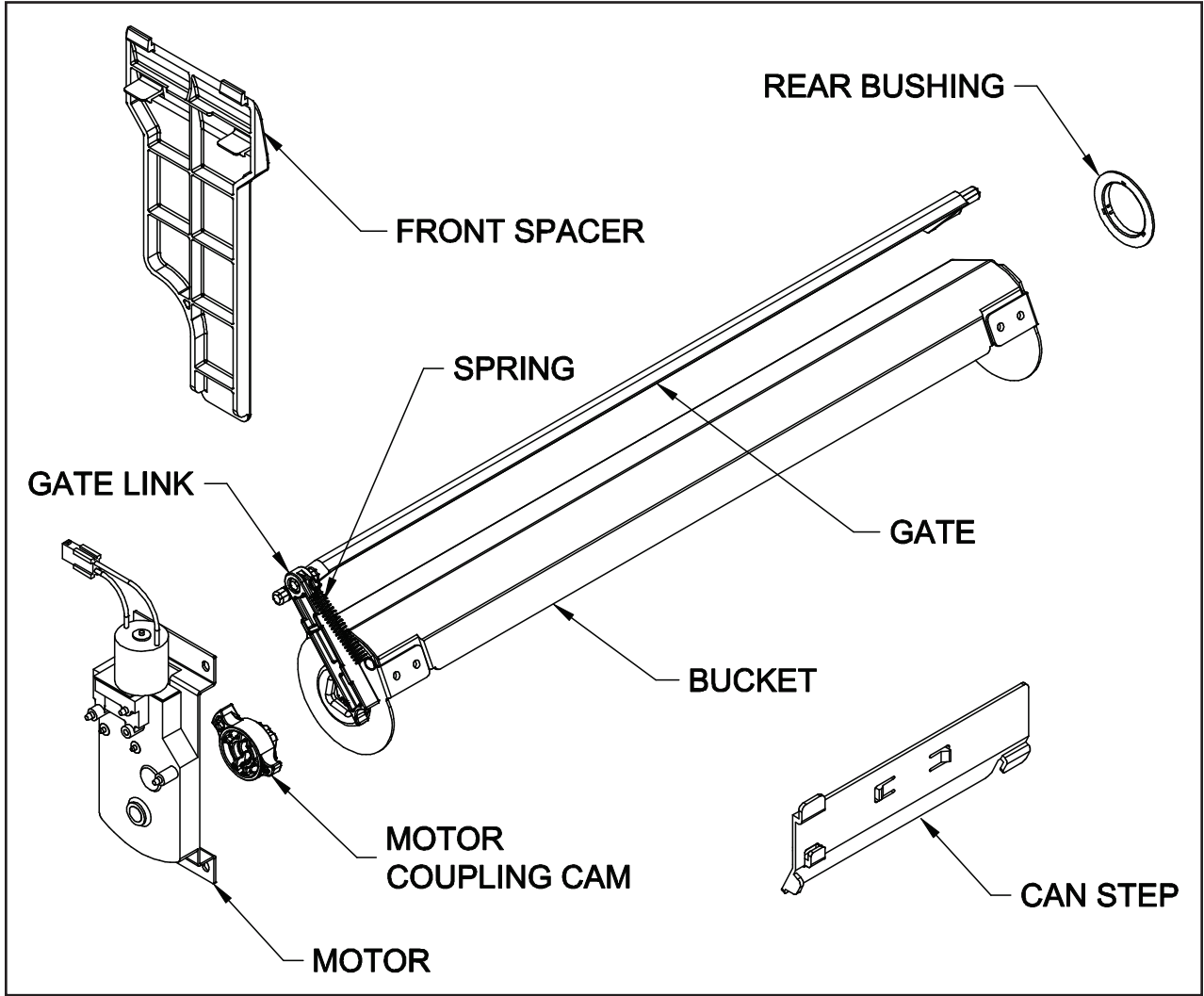

FIGURE 7



VEND CYCLE

Several operations take place during the vend cycle: When a selection is made, the coupler and bucket rotate, product is dispensed and the bucket is then reloaded. The sequence of these operations change slightly when the column's depth setting is changed. With the single depth setting, one purchase is made and the bucket is reloaded. With the double depth setting, two purchases are made before the bucket is reloaded. With the triple depth setting, three purchases are made before the bucket is reloaded. With the quadruple depth setting, four purchases are made before the bucket is reloaded. (See Figures 8 & 9)

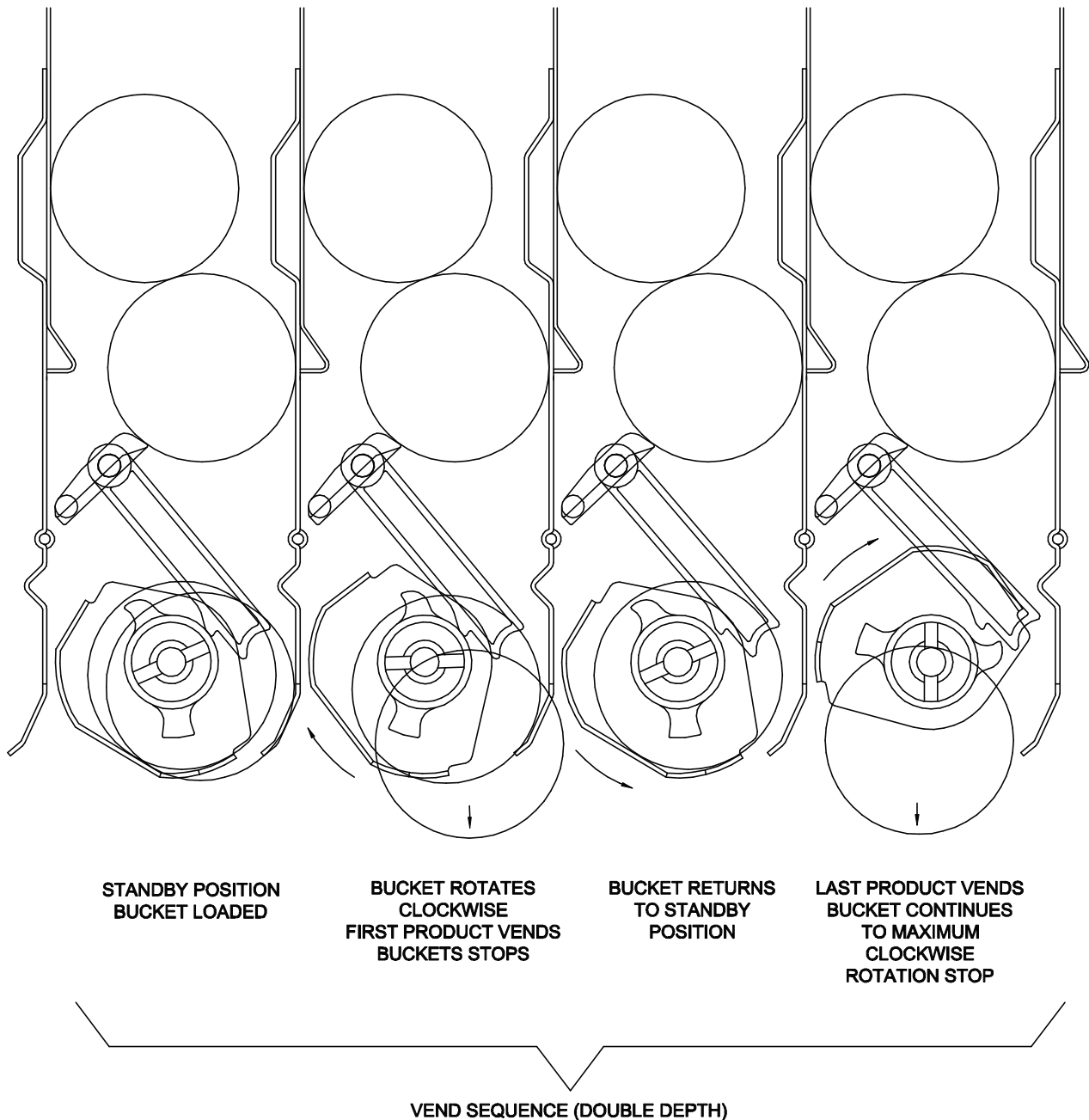
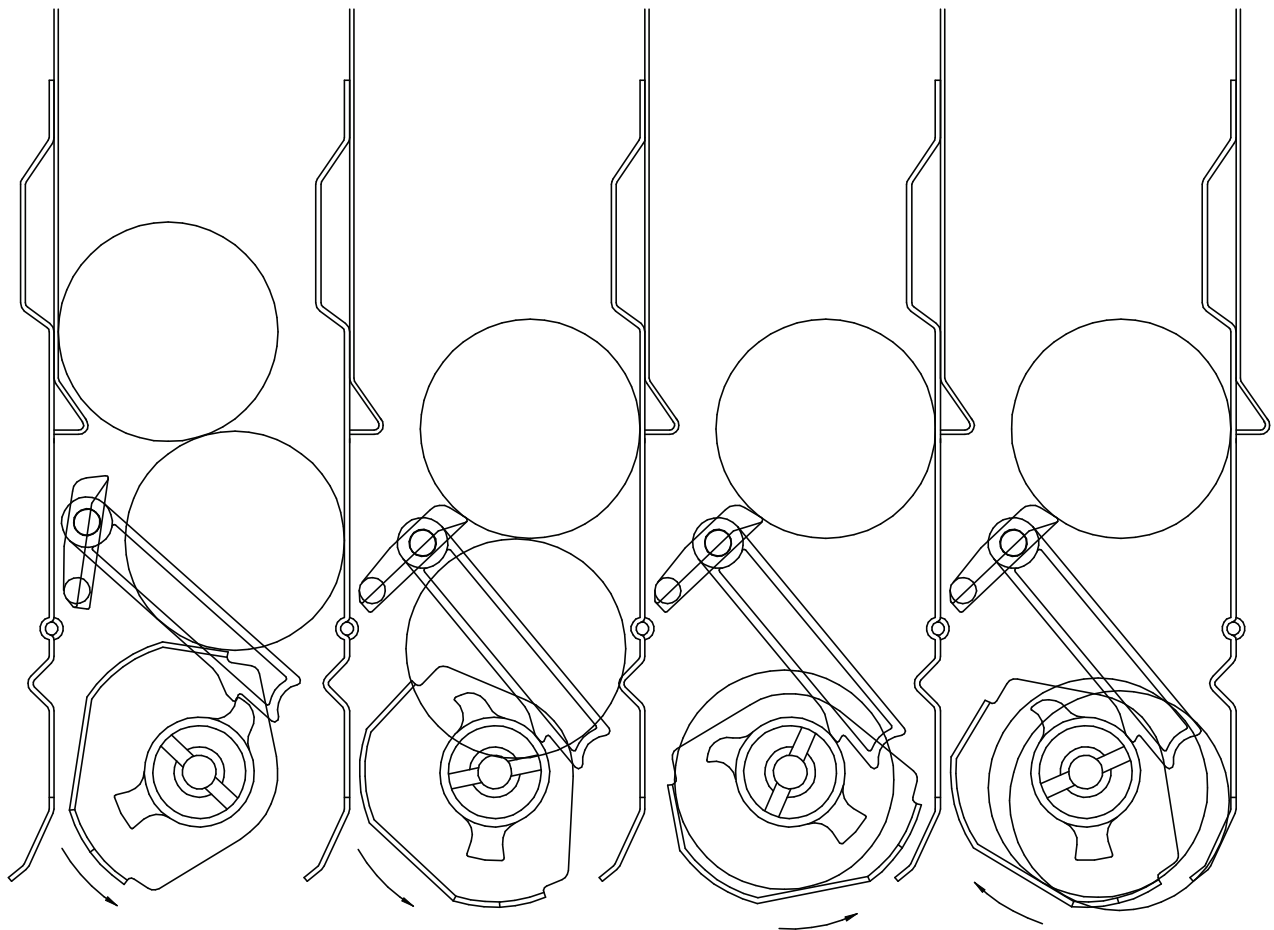

FIGURE 8



**BUCKET ROTATES
COUNTERCLOCKWISE
CAM PUSHES LINK
LINK OPENS GATE**

**BUCKET CONTINUES
COUNTERCLOCKWISE
GATE CLOSAS AS
PRODUCT LOWERS
INTO BUCKET**

**BUCKET REACHES
MAXIMUM
COUNTERCLOCKWISE
ROTATION STOP**

**BUCKET ROTATES
CLOCKWISE UNTIL IT
REACHES STANDBY
POSITION**

RELOAD SEQUENCE

FIGURE 9



NOTES



12.1 PROGRAMMING SECTION



All programming of the V21 is done in the service mode as indicated in the following steps below. The main service modes are indicated in white text and the sub-modes are indicated in black text.

Example:

time Time/Date Setting Mode

year

Year Setting

nth

Month Setting

date

Date Setting

hour

Hour Setting

dSt

Daylight Saving Time



THREE-BUTTON PROGRAMMING

All programming of the V21 control board is done in the service mode. To enter the service mode open the vendor door, find the service mode button located on the control board, then press and release the service mode button. To scroll through all the service modes, use selection button one.

The first three selection buttons are used to navigate through the programming as follows:

Button	Description	Usage
Selection Button 1	Up/Down	Increase/Decrease, Next/Previous
Selection Button 2	Enter	Go to sub-level, activate function
Selection Button 3	Exit	Return to previous level, exit, save

FIGURE 1

The controller will automatically return to the Open-Door Sales Mode if:

1. No information from the selection switches is received within approximately 30 seconds.
2. The service mode button is pressed a second time.
3. The (Exit) button is pressed.

When the programming is entered, any established credit is returned. When and if the door is closed, the controller will exit the service mode and return to the sales mode.

MIS Data

As soon as the outer door is opened, the non-resettable MIS data will be displayed if no errors exist. “**CASH XXX**” will flash for approximately 30 seconds, indicating the total number of units the machine has sold. After 30 seconds, “**CASH XX.XX**” will begin to scroll, indicating the total dollar amount the machine has accumulated. **NOTE:** Pressing selection button one will eliminate the 30-second wait time and advance you immediately to the “**CASH XX.XX**” scroll.

To access MIS data by individual selection, press selection button two during the “**CASH XXXX**” or “**CASH XX.XX**” scroll. Use selection button one to advance forward or backward through the selections. Please see page PG-7 to choose between count by selection or count by price.

NOTE: The MIS data that is displayed when the outer door is opened (“**CASH XXXX**” and “**CASH XX.XX**”) is non-resettable. This data is accumulated over the life of the control board and can only be changed by replacing the control board.



SET-UP AND CODE DESCRIPTION

Error Display Mode

If selection button two is pressed at the “Error” prompt, the controller will enter the Error Display Mode. If no errors have occurred, the display will show “000E”. If an error has been detected since the last error reset, the display will show the first error summary code that has occurred. If selection button three is pressed while displaying any summary code, the controller will return to the “Error” prompt.

Note: See the *Trouble Shooting* section for errors and how to clear them.

EXAMPLE: “CJ0” would indicate a column jam error in column 1.

Coin Pay Out/Tube Fill Mode

If selection button two is pressed at the “Coin” prompt, the controller will enter the Coin Pay Out Mode. Pressing selection one will scroll through the denominations and pressing selection button two will start the denomination flashing. The display will indicate the denomination along with the number of that coin stored in the coin mechanism. If selection button two is pressed, a pay out of the displayed value will be made. Coins will continue to pay out as long as that selection button is held down.

EXAMPLE: If selection button two is pressed while 5 cents is displayed it will pay out a nickel.

When the controller enters the “Coin” mode, the operator is allowed to deposit any coin into the coin changer’s acceptor when that coin’s tube is not full. The tube inventory level will be displayed after each coin is accepted.

Test Mode

If selection button two is pressed at the “Test” prompt, the controller will enter the Test Mode where you are able to test the motors, the display, the compressor, the lights, the evaporator fans and the heater.

Vend Testing

Pressing selection button two at the test mode will enter the controller into the vend test mode. Upon entry into the vend test mode the display will show the first summary test, “C01” (column 1). Pressing selection button one will scroll through the column selections. Pressing selection button two will test vend the displayed column. In order to exit the setting, press selection button three.



SET-UP AND CODE DESCRIPTION (CONTINUED)



Jogging the Column

Pressing selection button two at the “JOG” mode, will enter into the Jog test mode. Upon entry into the Jog test mode the display will show the first summary test, “COL” (column 1). Pressing selection button one will scroll through the column selections. Pressing selection button two will access FOR (forward) or REV (reverse). Pressing selection button two again will move the motor in the desired direction. To exit the setting, press selection button three.



Display Testing

Pressing selection button one at the Jog test mode will advance the controller to the Display test mode. Upon entry into the Display test mode the display will flash a series of lines and dashes if all characters in the display are operational. To exit the setting, press selection button three.



Relay Testing

Pressing selection button one at the display test mode will advance the controller into the Relay test mode which allows the user to test the lights, compressor, evaporator fans or the heater. Upon entry into the rely test mode the display will read “COMP” for the compressor test. To scroll through the components for testing, press selection button one. To activate the component, press selection button two and the “O” will begin to flash. Use selection button one to toggle between “O” (deactivate) and “I” (activate). Pressing selection button two will activate the component if the display reads “XXX1”. To exit the setting, press selection button three.

COMP/I – Compressor test

LIGHT/I – Light test

EVAP/I – Evaporator fan test

HEAT/I – Heater testing



MIS Data – Cash Mode

If selection button two is pressed at the “CASH” prompt, the display will show the non-resettable historical amount of money accepted by the machine. If selection button one is pressed, the display will show “\$:” (selection one) and the amount received for selection button one. Continue pressing selection button one to scroll through all of the selections. To exit the setting, press selection button three.



SET-UP AND CODE DESCRIPTION (CONTINUED)



MIS Data – Sales Mode

If selection button two is pressed at the “**SALE**” prompt, the display will show the non-resettable historical amount of units sold by the machine. If selection button one is pressed, the display will show “**SU 1**” (selection one) and the units sold for selection button one. Continue pressing selection button one to scroll through all of the selections. To exit the setting, press selection button three.



Cost Setting Mode

The purpose of this mode is to enable the controller to set the vend price for each of the selections. If selection button two is pressed at the “**COST**” prompt, the display will indicate “**SU 1**”. Pressing selection button one will scroll through all of the selections or “**ALL**” to have all the vend prices set at the same price. Pressing selection button two will enter into the displayed selection button. Pressing selection button one will change the displayed vend price. Pressing selection button two again will save the price and selection button three will exit the mode.



Discount Counter (Only shows when discounts are used)

The discount counter allows you to access the sales and cash data for vends that have been discounted. Press selection button #2 when the display reads **DC**. The display will change to read **CASH**. Press selection button #2 when the display reads **CASH**. The display will change to read **CASH** and XXXX.XX, where XXXX.XX is the value of all discounts towards paid sales. This total is non-resettable and begins when the discount feature is enabled. Pressing selection button #1 will scroll through all of the selection buttons and display the value of the discounts toward product sales. The amounts for the individual selections can be reset using the rules in the **OPTS** mode. To exit this mode, press selection button #3. The display will return to **CASH**. To advance to the sales information, press selection button #1. The display **CASH** will change to **SALE**. Press selection button #2 to access this information. The total number of discounted sales will be displayed. This total is non-resettable and begins when the discount feature is enabled. Pressing selection button #1 will scroll through all of the selection buttons and display each selection’s number of discounted sales. The amounts for the individual selections can be reset using the rules in the **OPTS** mode.



Free Counter (Only show if free vends during closed-door sales mode have been made)

The free counter allows you to access the sales and cash data (loss) for vends that have been free. Press selection button #2 when the display reads **FC**. The display will change to read XXXX.XX, where XXXX.XX is the value of all lost money based on the price value setting. This total is non-resettable and begins when the free vend override feature is enabled. Pressing selection button #1 will change to the second screen. The display will change to read **SALE** XXX.XX. It will display the total number of free vends that have occurred. This total is non-resettable and begins when the free vend override feature is enabled. Press selection button #3 to exit the mode.



SET-UP AND CODE DESCRIPTION (CONTINUED)



Depth Setting Mode

The purpose of this mode is to enable the controller to set the vending depth for each column. If selection button two is pressed at the “**DS**” prompt, the display will indicate “**0 X**”. Pressing selection button one will scroll through all of the columns. Pressing selection button two will enter into the displayed column. Pressing selection button one again will change the displayed depth settings from 1-4. Pressing selection button two will save the depth setting and selection button three will exit the mode.



Option Mode

If selection button two is pressed at the “**OPS**” prompt, the controller will enter the Option mode. The purpose of this mode is to allow the controller to select the configuration options desired.

Display	Description	Meaning
FS	Force Select	Force select enabled (y) or disabled (n)
BE	Bill Escrow	Bill Escrow enabled (y) or disabled (n)
SE	Error/Sold Out Indicator	Error/Sold Out indicator “ 0 ” enabled (y) or disabled (n)
SP	Single Price	Single Price enabled (y)/Multi-Price enabled (n)
ct	Count by Price/Count by Selection	y = count by price n = count by selection
CC	Correct Change Light	Correct Change Light enabled (y)/Correct Change Light disabled (n)
OP	Allow Overpay	Allow overpay enabled (y)/Allow overpay disabled (n)
SC	Save Credit	Credit will remain for 5 minutes (y)/ Credit will remain indefinitely (n)
nv	Multi Vend	Multi vend enabled, single vend disabled (y)/ Single vend enabled, multi vend disabled (n)
dl	Learning Mode*	Learning mode enabled (y)/Learning mode disabled (n)*
RR	Auto MIS reset	MIS data will reset with DEX read (y)/MIS data will not reset with DEX read (n)

FIGURE 2

* The learning mode uses self adaptive logic to “learn” what the depth setting of the column is, in the event that the control board depth setting isn’t programmed properly.



SET-UP AND CODE DESCRIPTION (CONTINUED)



Space-to-Sales Setting Mode

If selection button two is pressed at the “S&S” prompt, the controller will enter the Space-to-Sales option. Upon entry into this setting the display will show the current option setting. Pressing selection button one will scroll through the various space to sales options as listed below. Pressing selection button two will change the current option and selection button three will save the desired option. **For proper configuration settings refer to the label located on the inner door shear panel (See figure 3)**

SPACE-TO-SALES CONFIGURATIONS

SEL#	ST10	STS9	STS8	STS7	STS6	STS5	STS4	STS3	STS2	STS1
	COL	COL	COL	COL	COL	COL	COL	COL	COL	COL
1	1	1,2	1	1	1,2,3	1,2	1	1,2	ALL	NONE
2	2	1,2	2	2	1,2,3	1,2	1	1,2	ALL	NONE
3	3	3	3	3	1,2,3	3	2	3	ALL	NONE
4	4	4	4	4	4	4	2	4	ALL	NONE
5	5	5	5	5	5	5	3	5	ALL	NONE
6	6	6	6	6	6	6	4	6	ALL	NONE
7	7	7	7	7	7	7	5	7	ALL	NONE
8	8	8	8	~	8	8	6	8	ALL	NONE
9	9	9	~	~	9	~	7	9	ALL	NONE
10	10	10	~	~	10	~	8	9	ALL	NONE
11*	~	~	~	~	~	~	9	10	ALL	NONE
12*	~	~	~	~	~	~	10	10	ALL	NONE

FIGURE 3

* Where available

Note: If none of the space-to-sales configurations are suitable, the operator can use the Custom Space-to-Sales Setting Mode.



Custom Space-to-Sales Setting mode

If selection button two is pressed at the “CS&S” prompt, the controller will enter the Custom Space-to-Sales option. Upon entry into this setting the display will show the current selection setting followed by the columns connected to that selection button.

Programming Connection Option

If selection button two is pressed while “S X” is displayed, the display will change to “C :”. Pressing selection button one will increase or decrease the column number displayed. Pressing selection button two will actuate the changed connection status of the column number displayed. If the column number is flashing it is assigned to the selection that was entered. If the column number is steady, it is not assigned to the selection button. To exit this mode, press selection button three.



SET-UP AND CODE DESCRIPTION (CONTINUED)



Closed Door Data Retrieval Mode

If selection button two is pressed at the “CdDr” prompt, the controller will enter the Closed Door Data Retrieval Mode by displaying “XXXX” where “XXXX” is the password. Pressing selection button number one while the digits are flashing will change the current password. The available digits are 0-6. (**See note below.**) Pressing selection button two will save the change and advance to the next digit. In order to save the password and exit the mode, press selection button two while the last/fourth digit is flashing.

Note: If one of the digits in the password is “0” this feature will be disabled since selection button “0” does not exist.

Note: This feature is not available when the vend price is set to “0.00”.



Language Mode

If selection button two is pressed at the “Lang” prompt, the controller will enter the Language Mode by displaying the currently assigned language. The available languages are Eng – English, Frn – French, Ger – German, Itl – Italian, Port – Portuguese, and Esp – Spanish. Pressing selection button one will toggle through the language options. If selection button two is pressed, the display will save the language change and return the display to Lang.



Clock Setting Mode

If selection button two is pressed at the “Clock” prompt, the controller will enter the Clock Mode which allows you to set the clock on the control board. This field must be set in order to operate any modes associated with the time. Pressing selection button two while any of the options are displayed will enter you in to the clock setting options. Pressing selection button one will toggle you through the options. Pressing selection button three will exit this mode.

CLOCK SETTING OPTIONS	
Year	Current Year (Example: 2002)
Date	Current Date (month, day)
Hour	Current Time (hours, minutes)
DST	Daylight Savings Time
Ctrl	Clock Control



SET-UP AND CODE DESCRIPTION (CONTINUED)



Lighting Control Mode

If selection button two is pressed at the “**LiE**” prompt, the controller will enter the Lighting Control Mode which allows you to have the lights turned off and on during specific time periods to conserve energy. Pressing selection button two while any of the settings are displayed will enter you in to the light control settings. Pressing selection button one will toggle you through the options. Pressing selection button three will exit this mode.

LIGHTING CONTROL SETTINGS	
Enb	Lighting control enabled (1)/disabled (0)
Str1	Start Time – Time lights shut off
dR4	Days associated with start time
Hour	Hour associated with start time
End1	End Time – Time lights turn back on
dR4	Days associated with end time
Hour	Hour associated with end time
Str2	2 nd Start time – time lights shut off
dR4	Days associated with 2 nd start time
Hour	Hour associated with 2 nd start time
End2	2 nd End Time – Time lights turn back on
dR4	Days associated with 2 nd end time
Hour	Hour associated with 2 nd end time



Refrigeration Mode

If selection button two is pressed at the “**rfC**” prompt, the controller will enter the Refrigeration Control Mode by displaying “**SEtP**” for set point temperature. Pressing selection button two again enters the temperature settings from “hhhh”(warmest) to “cccc”(coldest). Pressing selection button one will toggle through the settings. If selection button two is pressed, the display will return to “**SEtP**”. Pressing selection button one will change the display to “**ENP**” for temperature. To view the temperature, press selection button two. To change the degree scale, press selection button two when the display reads “**FoFC**” for Fahrenheit or Celsius. To change the current degree scale, press selection button one to scroll between F and C. Pressing selection button two will return the display to “**FoFC**”.

Note: The displayed thermostat setting and the actual temperature sensor reading for refrigeration control are listed below in Figure 4:



SET-UP AND CODE DESCRIPTION (CONTINUED)

Thermostat Setting Displayed	cccc	ccc	cc	c	norn	h	hh	hhh	hhhh
Cut-in Temperature (F)	34°	35°	36°	37°	38°	39°	40°	41°	42°
Cut-out Temperature (F)	30°	31°	32°	33°	34°	35°	36°	37°	38°
Nominal Temperature (F)	32°	33°	34°	35°	36°	37°	38°	39°	40°
Nominal Temperature (C)	0	0.6	1.1	1.7	2.2	2.8	3.3	3.9	4.4

FIGURE 4

There are two submodes within the refrigeration mode that can be activated to achieve energy conservation

The first submode, **FRnX**, refers to an optional evaporator fan relay. When X =

- 0 - the fan mode is disabled and the evaporator will turn on/off with the activation of the compressor
- 1 - (Fan Mode 1) the evaporator fan will turn off 5 minutes after the compressor fan is turned off

The second submode, **DEFX**, refers to the Periodic Defrost mode. If X =

- 0 - the periodic defrost mode is disabled
- 1 - the machine will defrost every 6 hours for 30 minutes - used in high humidity environments .

Within the refrigeration mode, there is also a refrigeration conservation mode which raises the cabinet temperature 18° F or 10° C during specified periods of time. Pressing selection button two while any of the settings are displayed will enter you in to the refrigeration control settings. Pressing selection button one will toggle you through the options. Pressing selection button three will exit this mode.



SET-UP AND CODE DESCRIPTION (CONTINUED)

REFRIGERATION CONTROL SETTINGS	
ᄀᄀᄀ	Refrigeration control enabled (1)/disabled (0)
ᄀᄀᄀ	Start Time – Time temperature rises 18°F/10°C
ᄀᄀᄀ	Days associated with start time
ᄀᄀᄀ	Hour associated with start time
ᄀᄀᄀ	End Time – Time temperature returns
ᄀᄀᄀ	Days associated with end time
ᄀᄀᄀ	Hour associated with end time
ᄀᄀᄀ	2 nd Start time – Time temperature rises 18°F/10°C
ᄀᄀᄀ	Days associated with 2 nd start time
ᄀᄀᄀ	Hour associated with 2 nd start time
ᄀᄀᄀ	2 nd End Time – Time temperature returns
ᄀᄀᄀ	Days associated with 2 nd end time
ᄀᄀᄀ	Hour associated with 2 nd end time

“ᄀᄀᄀ” – Monday

“ᄀᄀᄀ” – Tuesday

“ᄀᄀᄀ” – Wednesday

“ᄀᄀᄀ” – Thursday

“ᄀᄀᄀ” – Friday

“ᄀᄀᄀ” – Saturday

“ᄀᄀᄀ” – Sunday

“ᄀᄀᄀ” – All Days



Block Selection Setting

This feature is used to choose a group of selections and the time when those selections will be blocked from vending product. If selection button two is pressed at the “ᄀᄀᄀ” or “ᄀᄀᄀ” prompt, the controller will enter the Selection Blocking Control Mode. Upon entry into this program, the display will show the first sub-mode “ᄀᄀᄀ” or “ᄀᄀᄀ” depending on which blocking mode you are using. Using selection button one will let the operator toggle between the following modes:



SET-UP AND CODE DESCRIPTION (CONTINUED)

BLOCK SELECTION OPTIONS	
On:	Controls blocking option
Sel:	Set selection buttons – (y) assigned/(n) not assigned
Sto:	Set time for machine to turn off
dAY	Set days for blocking to start
hour	Set hours for blocking to start
StoP:	Set time for machine to turn back on
dAY	Set days for blocking to stop
hour	Set hours for blocking to stop



Discount Setting Mode

This feature is used to choose a group of selections that will be discounted, the amount of discount, and the time when the discount will occur. If selection button two is pressed at the “d:SC” prompt, the controller will enter the Discount Setting Mode. Upon entry into this program the display will show “On:”. If selection button one is pressed it will toggle through the discount setting mode as listed below. Pressing selection button three will save the settings and return to the “d:SC” mode.

DISCOUNT SETTING OPTIONS	
On:	Turns the discount setting On/Off
SelSC	Set selection buttons – (y) assigned/(n) not assigned
StoP	Set time for discounting to begin
dAY	Set days to discount
Hour	Set time for discounting to begin
StoP	Set time for discounting to stop
dAY	Set days for discounting to stop
Hour	Set time to start (24 hours)
LESS	Set discount amount



SET-UP AND CODE DESCRIPTION (CONTINUED)



Over-Ride Mode (Units equipped with optional key switch)

This feature is used to allow you to manually over-ride (via a key switch) pricing, blocking, low energy operation and discounting. If selection button two is pressed at the “OUEr” prompt, the controller will enter the Over-Ride Mode. Upon entry into this program the display will show “FrEn”. If selection button one is pressed it will cycle through the over-ride setting options as listed below. Pressing selection button three will save the currently displayed setting and return the operator to the “OUEr” prompt.

OVER-RIDE SETTING OPTIONS	
FrEn	Enable/Disable free vend (Edit mode Y/N)
bLk	Selection blocking over-ride
LiG	Lighting over-ride
rFr	Refrigeration over-ride
dSc	Discounting over-ride



Over-Ride Free Vend

If selection button two is pressed at the “FrEn” prompt, the controller will enter the Free Vend Enable Option. Upon entry into this program the display will show the current setting “FrEn”. Press selection button two. Pressing selection button one will toggle between “y” for enabled and “n” for disable. Pressing selection button two will save the currently displayed setting. Pressing selection button three will return the operator to the “FrEn” prompt.

“Y” = Enable free vend.

“N” = Disable free vend.



Over-Ride Selection Blocking

If selection button two is pressed at the “bLk” prompt, the controller will enter the Selection Blocking Over-Ride Enable Option. Upon entry into this program the display will show the current setting “bLk”. Press selection button two. Pressing selection button one will toggle between “Y” for enable and “N” for disable. Pressing selection button two will save the currently displayed setting. Pressing selection button three will return the operator to the “bLk” prompt.

“Y” = Enable selection blocking.

“N” = Disable selection blocking



SET-UP AND CODE DESCRIPTION (CONTINUED)

A black square icon containing the word "Light" in a white, pixelated font.

Over-Ride Lighting

If selection button two is pressed at the “Light” prompt, the controller will enter the Lighting Over-Ride Option. Upon entry into this program the display will show the current setting “Light” for enable and “Light” for disable. Pressing selection button one will toggle between “y” for enabled and “n” for disable. Pressing selection button two will save the currently displayed setting. Pressing selection button three will return the operator to the “Light” prompt.

“Y” = Enable Over-Ride Lighting blocking.

“N” = Disable Over-Ride Lighting blocking

A black square icon containing the word "Refrigeration" in a white, pixelated font.

Over-Ride Refrigeration

If selection button two is pressed at the “Refrigeration” prompt, the controller will enter the Refrigeration Over-Ride Option. Upon entry into this program the display will show the current setting “Refrigeration” for enable and “Refrigeration” for disable. Pressing selection button one will toggle between “y” for enabled and “n” for disable. Pressing selection button two will save the currently displayed setting. Pressing selection button three will return the operator to the “Refrigeration” prompt.

“Y” = Enable refrigeration over-ride.

“N” = Disable refrigeration over-ride.

A black square icon containing the word "Discount" in a white, pixelated font.

Over-Ride Discount

If selection button two is pressed at the “Discount” prompt, the controller will enter the Discounting Over-Ride Enable Option. Upon entry into this program the display will show the current setting “Discount” for enable and “Discount” for disable. Pressing selection button one will toggle between “y” for enabled and “n” for disable. Pressing selection button three will save the currently displayed setting and return the operator to the “Discount” prompt.

“Y” = Enable discount over-ride.

“N” = Disable discount over-ride.



12.1 WIRING DIAGRAM

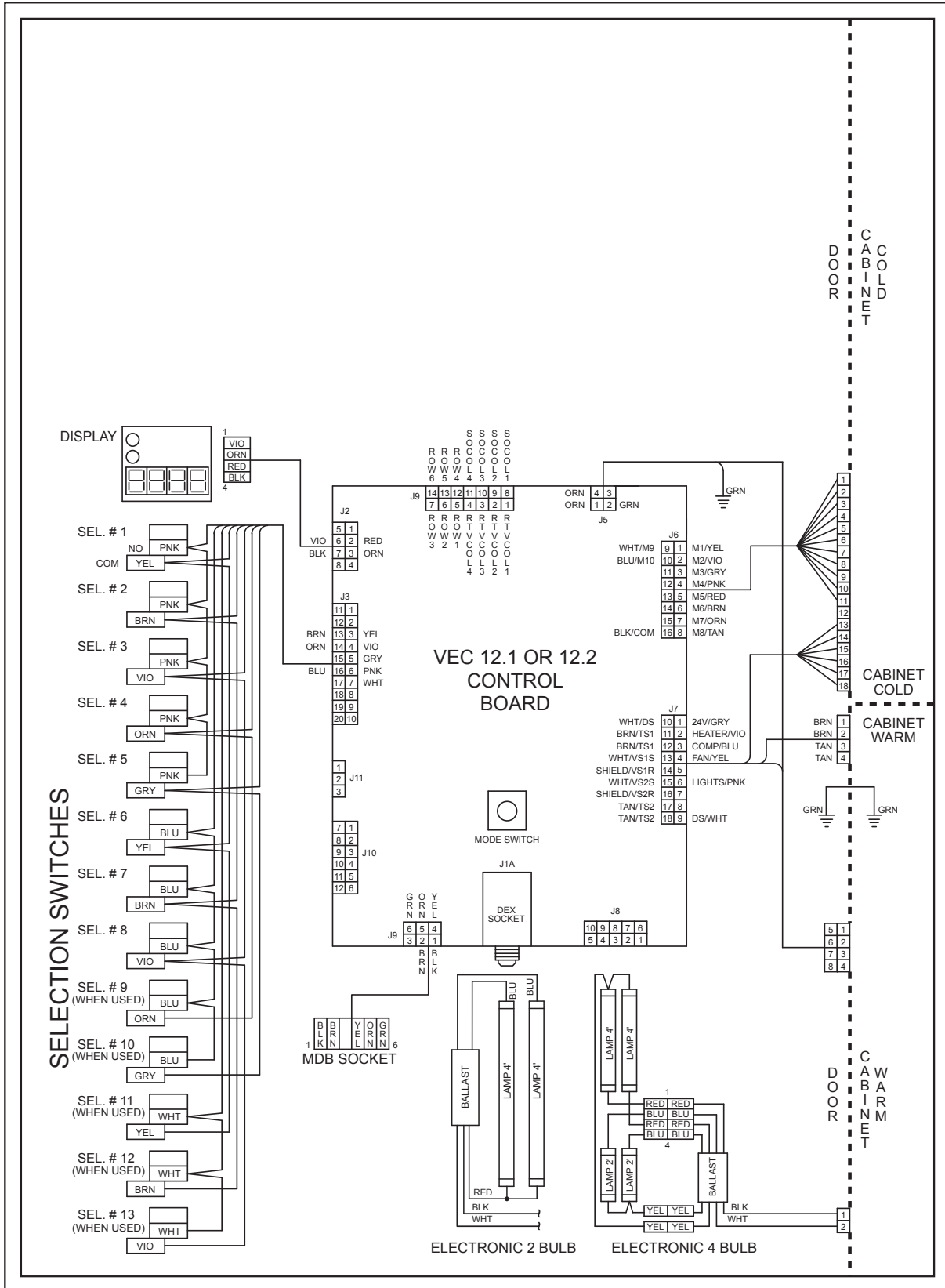



12.1 WIRING DIAGRAM (CONTINUED)

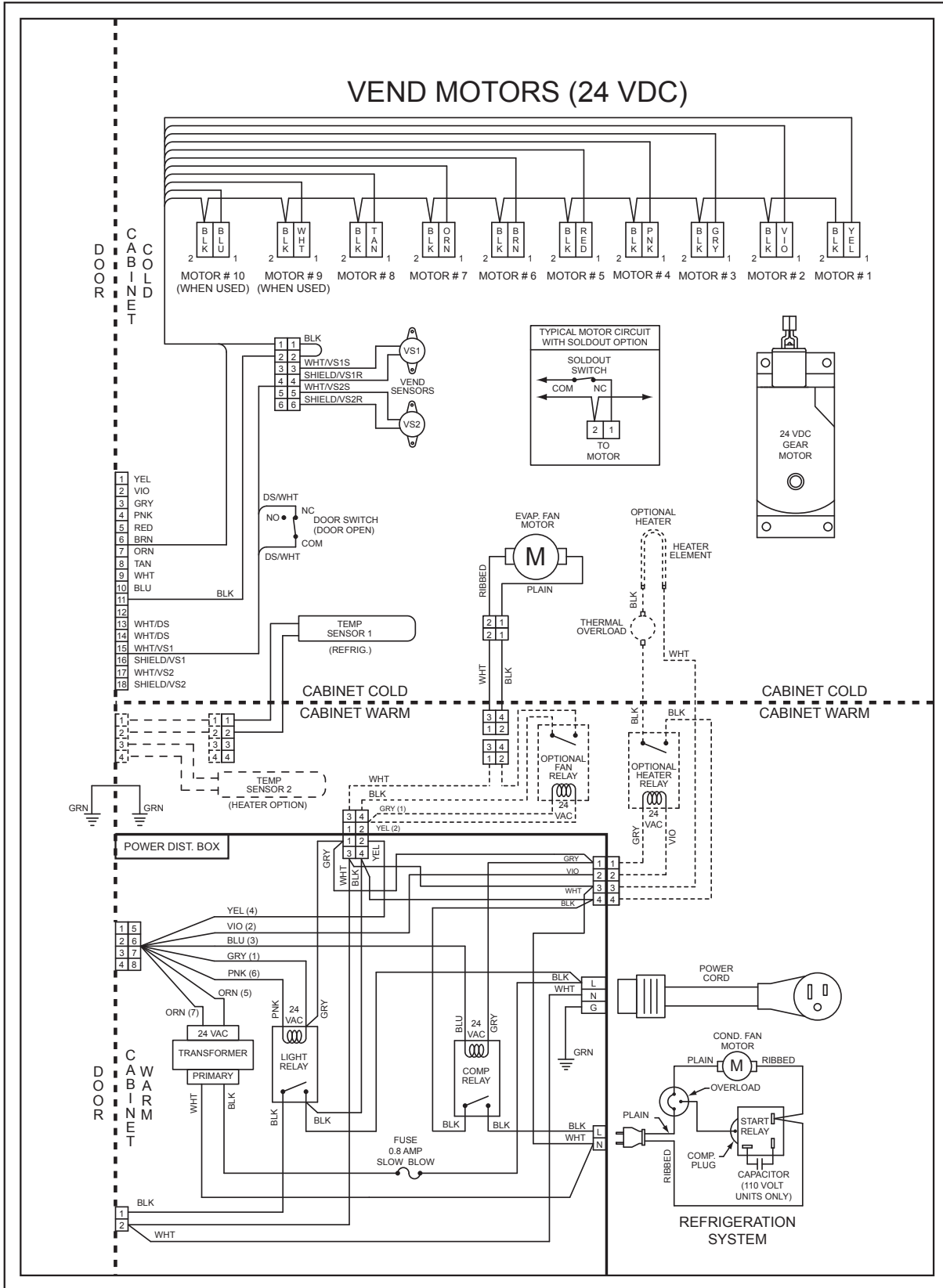



NOTES

1. If the outer door is left open for over an hour, the lights, and compressor will become active. In order to over-ride this option, press the door switch one time.



CABINET PARTS SECTION



READING A PARTS LIST

- I **ITEM NUMBER** is found in two locations:
 - A. It is on the drawing plate, and identifies the part and its location;
 - B. The same number is in the parts lists and ties the two together.
 - II **PART NUMBER** is the part number that has been assigned to a specific part by Vendo, for easier identification.
 - III **QUANTITY REQUIRED** relates to the amount required of a part, or will be indicated by "A/R" (as required) to attach it to another part.
 - IV **PART NAME AND DESCRIPTION** is the general description for the part, for easier identification when ordering a like part.
 - V **HARDWARE** is identified by a letter in a hexagon. Refer to hardware list section or description and part numbers. See pages C-4 and C-5.
-

The example below will show how the parts are listed in the parts lists:

- 1. **VEND MOTOR ASSEMBLY:** This is the main assembly name, and any replaceable parts will be indented below the assembly.
- 2. **RETAINER CAM:** This is an individual part, and will be indented. These indented parts can be ordered separately, so you do not need to order the entire assembly.
- 3. Whenever an assembly is ordered, all the parts that are indented will be included in the assembly. Any hardware will be listed next to their corresponding parts.
- 4. Any parts that may be ordered separately will not have any indented parts listed below them.

ITEM NO	DESCRIPTION	QTY REQ	PART NO.
1	VEND MOTOR ASSEMBLY	~	1115821
2	RETAINER CAM	1	1113244
3	TIMING CAM	1	1113236

If an asterisk is listed below the parts list, it is an indication that special information is noted. There may be more than one asterisk (*) (**) (***) denoting special notes.



























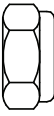
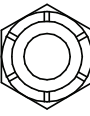

Purposely left blank

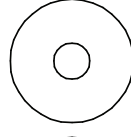

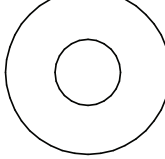
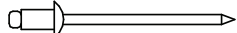
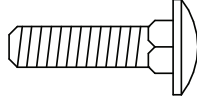
HARDWARE LIST

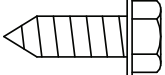
PART NO.	DESCRIPTION	PICTORIAL
A	V800762 #8 X 5/16" TAPPING SCREW	
B	V802139 #8 X 5/8" TAPPING SCREW	
C	V800586 #8 X 3/8" TAPPING SCREW W / LOCK WASHER	
D	V802214 #8 X 1/2" TAPPING SCREW (FOR PLASTIC)	
E	V801475 #8 X 1/2" TAPPING SCREW	
F	V801421 #10 X 5/16" TAPPING SCREW	
G	V802212 #10 X 3/8" TAPPING SCREW	
H	V802047 #10 X 5/16" TAPPING SCREW W / LOCK WASHER	
I	V802141 #10 X 1/2" TAPPING SCREW	
J	V801422 #10 X 1/2" TAPPING SCREW	
K	V801489 #10 X 1/2" SELF DRILLING SCREW	
L	V800512 #10 X 1-3/8" TAPPING SCREW	
M	V802115 #10 X 1" BOLT	
N	V801360 1/4" X 1/2" TAPPING SCREW W / LOCK WASHER	
O	V801343 1/4" X 1" TAPPING SCREW	
P	V801490 1/4" X 1" SELF DRILLING SCREW	
Q	V802053 1/4" X 2-1/4" BOLT	
R	V802069 1/4" X 5/8" CARRIAGE BOLT	
S	V801434 1/4" X 3/4" CARRIAGE BOLT	



T	V800267	1/4" X 3/8" BOLT		
U	V800956	#8 NUT W / LOCK WASHER		
V	V800952	#10 NUT W / LOCK WASHER		
W	V802111	#10 HEX NUT		
X	V802113	#10 LOCK NUT W / NYLON INSERT		
Y	V800959	1/4" NUT W / LOCK WASHER		
Z	387925	1/4" LOCK NUT W / NYLON INSERT		
AA	V802062	3/8" LOCK NUT W / NYLON INSERT		
AB	V801013	#10 FLAT WASHER		
AC	389026	#10 FLAT WASHER, LARGER O.D.		
AD	V801491	3/8" FLAT WASHER		
AE	V801412	1/8" POP RIVET		
AF	V801435	1/4" 20 X 1" CARRIAGE BOLT		
AG	V802220	1/4" X 3/4" TAPPING SCREW		
AH	1123719	SPACER		

1

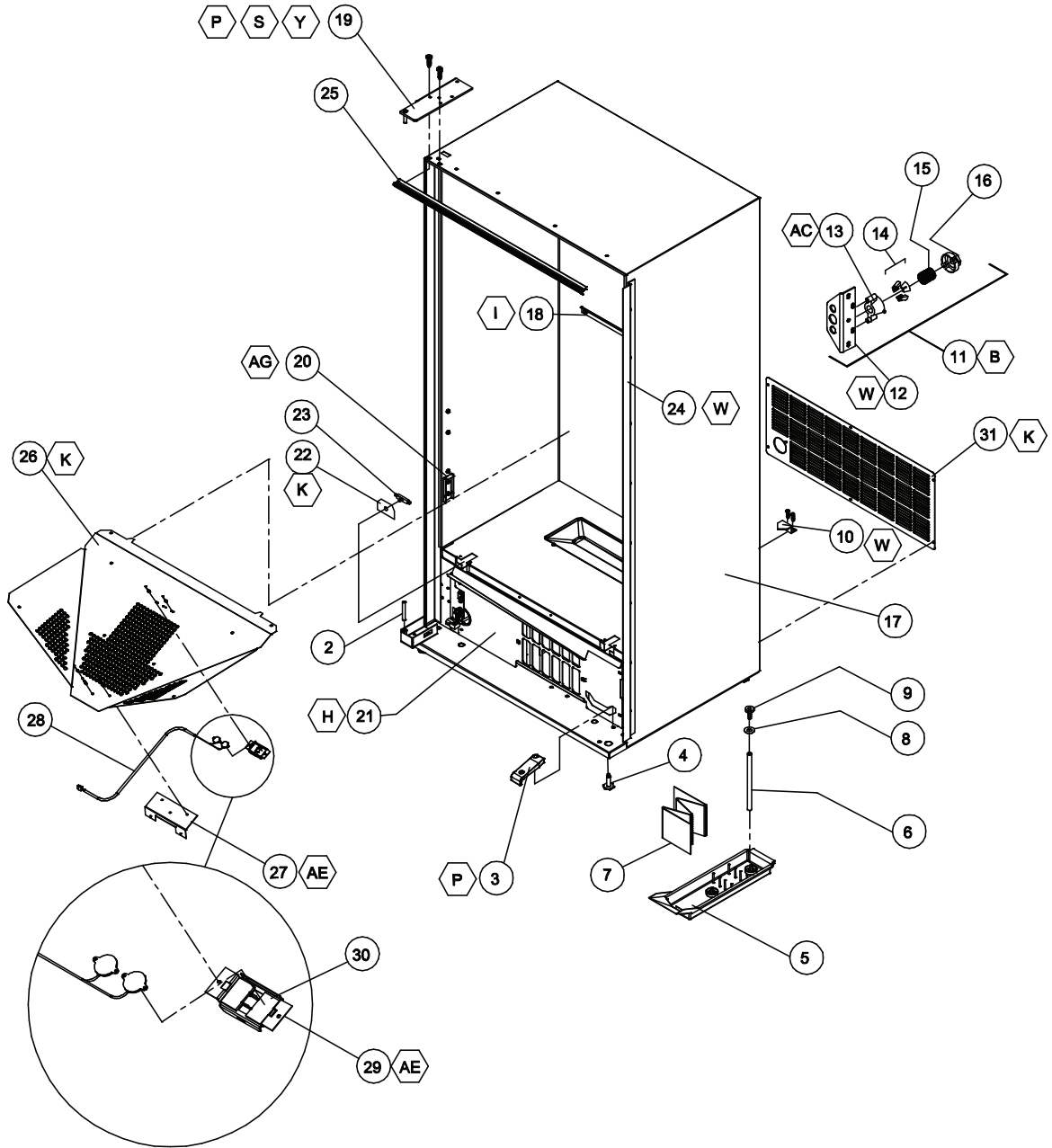



CABINET ASSEMBLY

ITEM NO	DESCRIPTION	QTY REQ	PART NO.
1*	CABINET ASSEMBLY - FOAMED	1	~
2	HINGE PIN	1	389071
3	RAMP	1	1120387
4	LEVELING LEG	1	1059902
5	CONDENSATE PAN	1	1122475
6	DRAIN TUBE	1	1088449-1
7	FIBERGLASS EVAPORATOR BOARD	1	1122728
8	DRAIN TUBE GASKET	1	387837
9	DRAIN TUBE FUNNEL	1	1068678
10	BRACKET - REFRIGERATION	2	1123527
11	QUICKER LOCK ASSEMBLY	1	1123724
12	LATCH BRACKET	1	1123675
13	NUT RETAINER HOUSING	1	1123689
14	NUT SEGMENT	3	1033085
15	SPRING	1	389690
16	CAP	1	1111988
17**	SIDE DECAL	2	**
18	STACK SUPPORT	1	1123018
19	TOP HINGE	1	2000805-03
20	BRACKET STACK SUPPORT	2	1079007
21	AIR DAM/KICK PANEL ASSEMBLY, 39"	1	1123440
~	AIR DAM/KICK PANEL ASSEMBLY, 32"	1	1123440-1
22	DOOR SWITCH BRACKET	1	1121043
23	DOOR SWITCH	1	323007
24	OVERLAPPING DOOR GUARD - 72"	1	2001376
~	OVERLAPPING DOOR GUARD - 79"	1	2002325
25	SEAL, 39"	1	1122500
26	VEND CHUTE, 39"	1	1123453
~	VEND CHUTE, 32"	1	1123451
27	CHUTE BRACKET	1	1077864
28	DROP SENSOR	1	1122923
29	DROP SENSOR MOUNTING BRACKET	1	1123601
30	FOAM PAD, DROP SENSOR	2	1123654
31	SAFETY SCREEN, 39"	1	1122568
~	SAFETY SCREEN, 32"	1	1122568-1

* NOTE: WHEN ORDERING CABINET ASSEMBLY, PLEASE PROVIDE **9-CODE** OR **11-CODE** AND **MANUFACTURER'S DATE CODE**.

NOTE: WHEN ORDERING DECALS, PLEASE PROVIDE **STYLE.

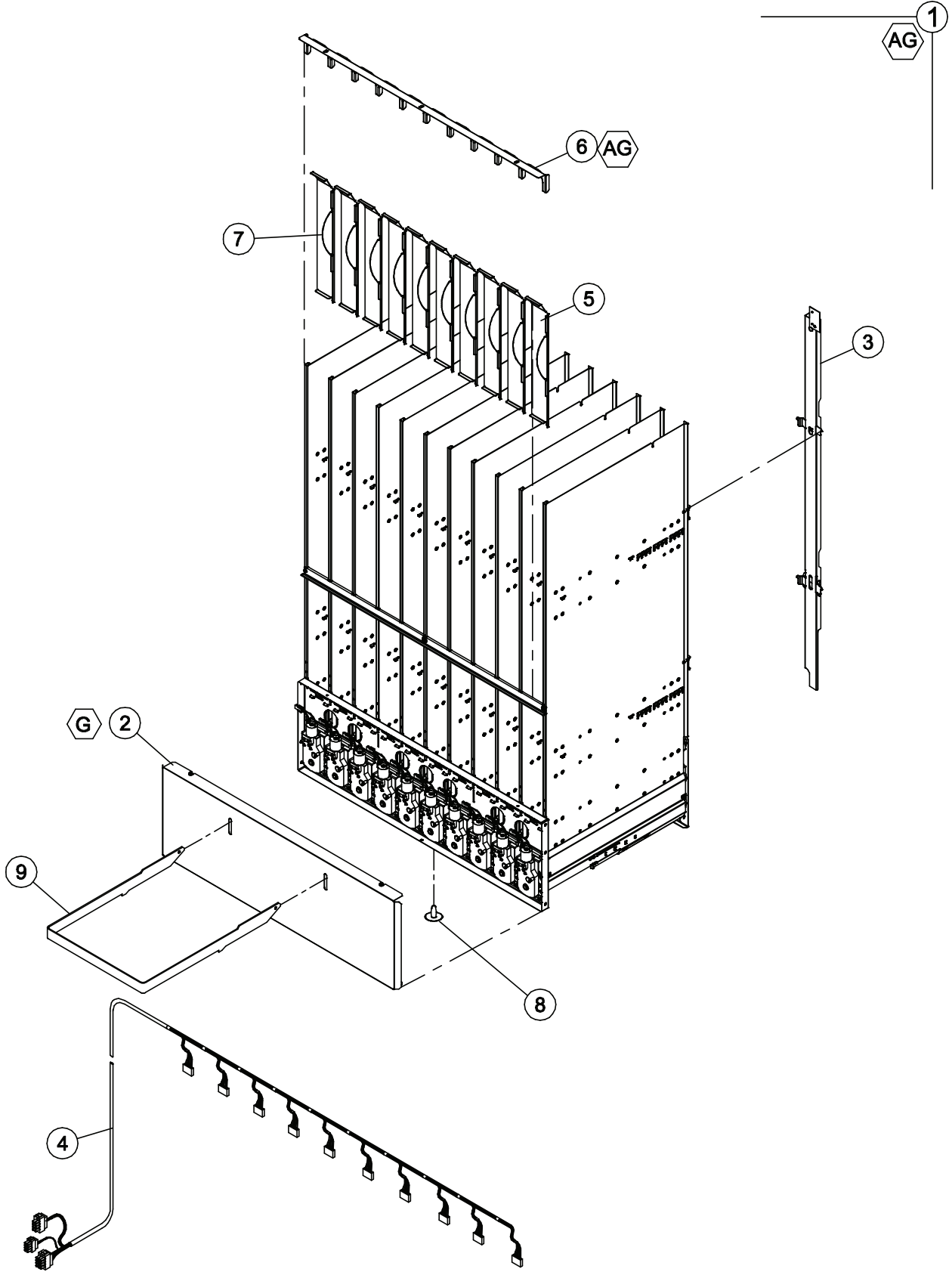



STACK ASSEMBLY

ITEM NO	MODEL NUMBER		721	821	621
	DESCRIPTION	QTY REQ	PART NO.	PART NO.	PART NO.
1	STACK CHASSIS ASSEMBLY	1	1123591-02	1123591-03	1123591-01
2	MOTOR COVER	1	1123003	1123003	1123037
3	BACK SPACER ASSEMBLY	*	1123047-1	1123047	1123047-1
4	MOTOR HARNESS	1	1122918	1122918	1123050
~	MOTOR HARNESS W/ PRE-COOL	1	1124065	1124065	1124066
5	LOWER RETAINER	*	1124868	1124868	1124868
6	TOP STACK STRAP	1	1122809	1122809	1123039
7	FRICTION WIRE	*	1123347	1123347	1123347
8	SNAP IN PLUG	1	V802043	V802043	V802043
9	LOADING RACK	1	1123662	1123662	1123662

*MODELS 721 & 821 USE 10 EACH.
 MODEL 621 USES 8 EACH.

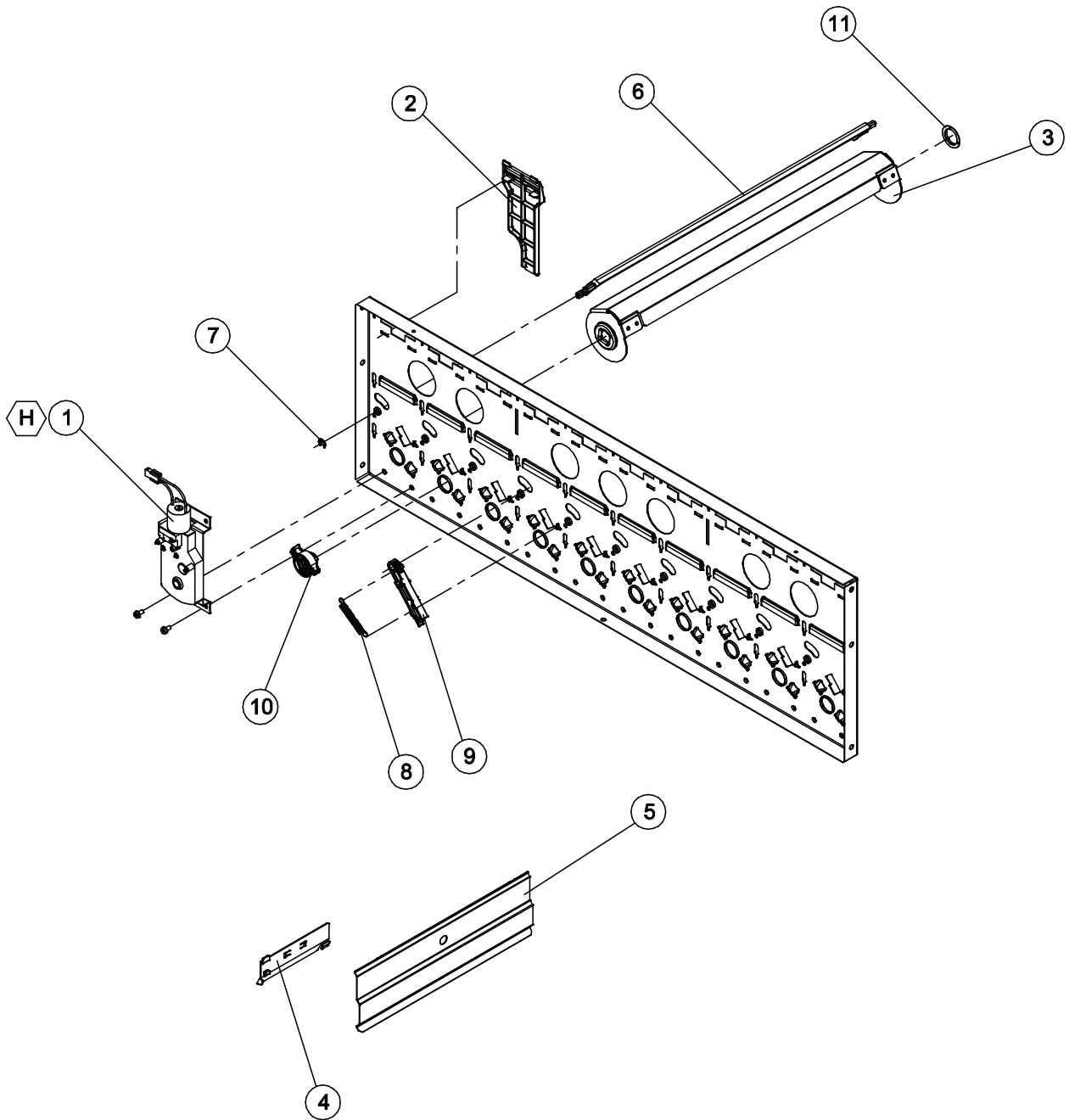



MECH PLATE ASSEMBLY

ITEM NO	MODEL NUMBER	721/821		621	
	DESCRIPTION	QTY REQ	PART NO.	QTY REQ	PART NO.
1	VEND MOTOR ASSEMBLY	10	1122820	8	1122820
2	FRONT SPACER	10	1122814	8	1122814
3	VEND BUCKET	10	1122815	8	1122815
4	CAN CLIP	10	1122856	8	1122856
5	* PRODUCT SPACER, 2.4 DIA	AR	1122928	AR	1122928
6	GATE	10	1122818	8	1122818
7	E-CLIP - GATE	10	V801080	8	V801080
8	SPRING	10	390326	8	390326
9	GATE LINK	10	1122819	8	1122819
10	COUPLING CAM	10	1122817	8	1122817
11	REAR BUSHING	10	1122816	8	1122816

*DEPENDING ON PRODUCT

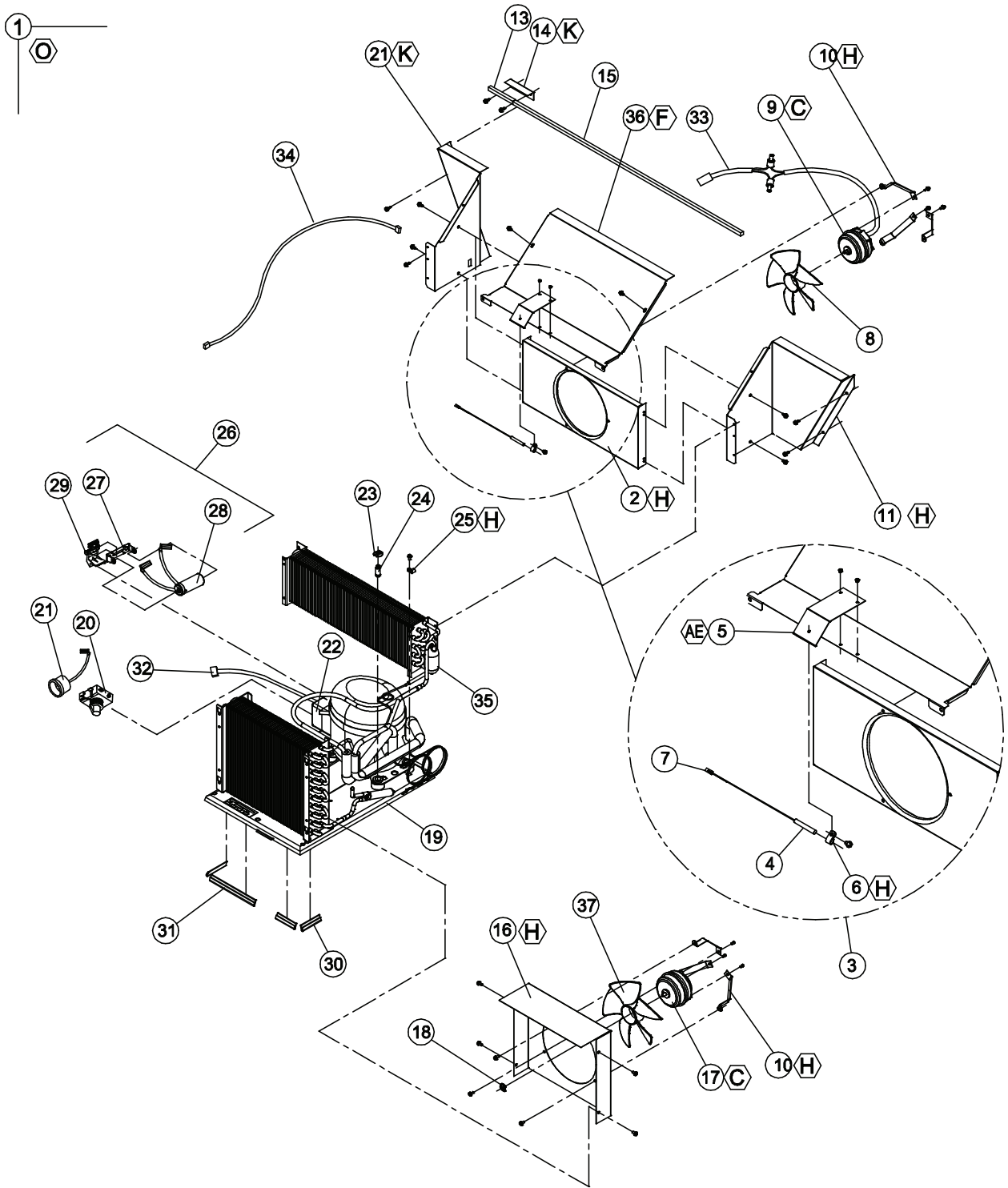



REFRIGERATION ASSEMBLY

ITEM NO	DESCRIPTION	QTY REQ	PART NO.
1	REFRIGERATION ASSEMBLY D90 TE S 1/3 R134a CAP START	1	1123589
2	ORIFICE PLATE, SINGLE FAN	1	390228
3	TEMPERATURE SENSOR ASSEMBLY	1	1124254
4	TEMPERATURE SENSOR	1	1122924
5	TEMPERATURE SENSOR BRACKET	1	1124156
6	CLAMP, 1/4"	1	324099-2
7	PUSH MOUNT CLAMP	1	384692
8	EVAPORATOR FAN BLADE	1	1113562
9	FAN MOTOR - EVAPORATOR	1	42321-17
10	BRACKET - FAN MOTORS	6	1117996
11	RIGHT AIR BAFFLE - EVAPORATOR	1	1123564
12	SMALL AIR DUCT - EVAPORATOR	1	1124097
13	FOAM TAPE, 3.5"	1	1124421-2
14	EVAPORATOR EXTENSION BRACKET	1	1124158
15	FOAM TAPE, 32.5"	1	1124421
16	CONDENSER DUCT	1	1122413
17	FAN MOTOR - CONDENSER, 115V	1	1121770
18	FAN MOTOR CLIP - CONDENSER	1	V42323
19	BASE - REFRIGERATION	1	1122470
20	START RELAY (PART OF ASSY 513506066)	1	--
21	OVERLOAD PROTECTOR (PART OF ASSY 513506066)	1	--
22	COVER - OVERLOAD (PART OF ASSY 513506066)	1	--
23	CLIP - COMPRESSOR MOUNT	2	343874
24	STUD - COMPRESSOR MOUNT	2	390102
25	CLAMP, 5/16"	1	324099-3
26	CAPACITOR ASSEMBLY	1	1112805
27	BRACKET - CAPACITOR	1	1112848
28	CAPACITOR-START/END	1	1122999
29	CAPACITOR CLIP	1	1076481
30	EDGE TRIM - SHORT	3	388304-1
31	EDGE TRIM - LONG	1	388304-3
32	COMPRESSOR POWER HARNESS	1	1121019-1
33	EVAPORATOR FAN HARNESS	1	1122193
34	EVAPORATOR POWER HARNESS	1	1124185
35	EVAPORATOR	1	1122235
36	EVAPORATOR COVER	1	1124099
37	CONDENSER FAN BLADE	1	389614

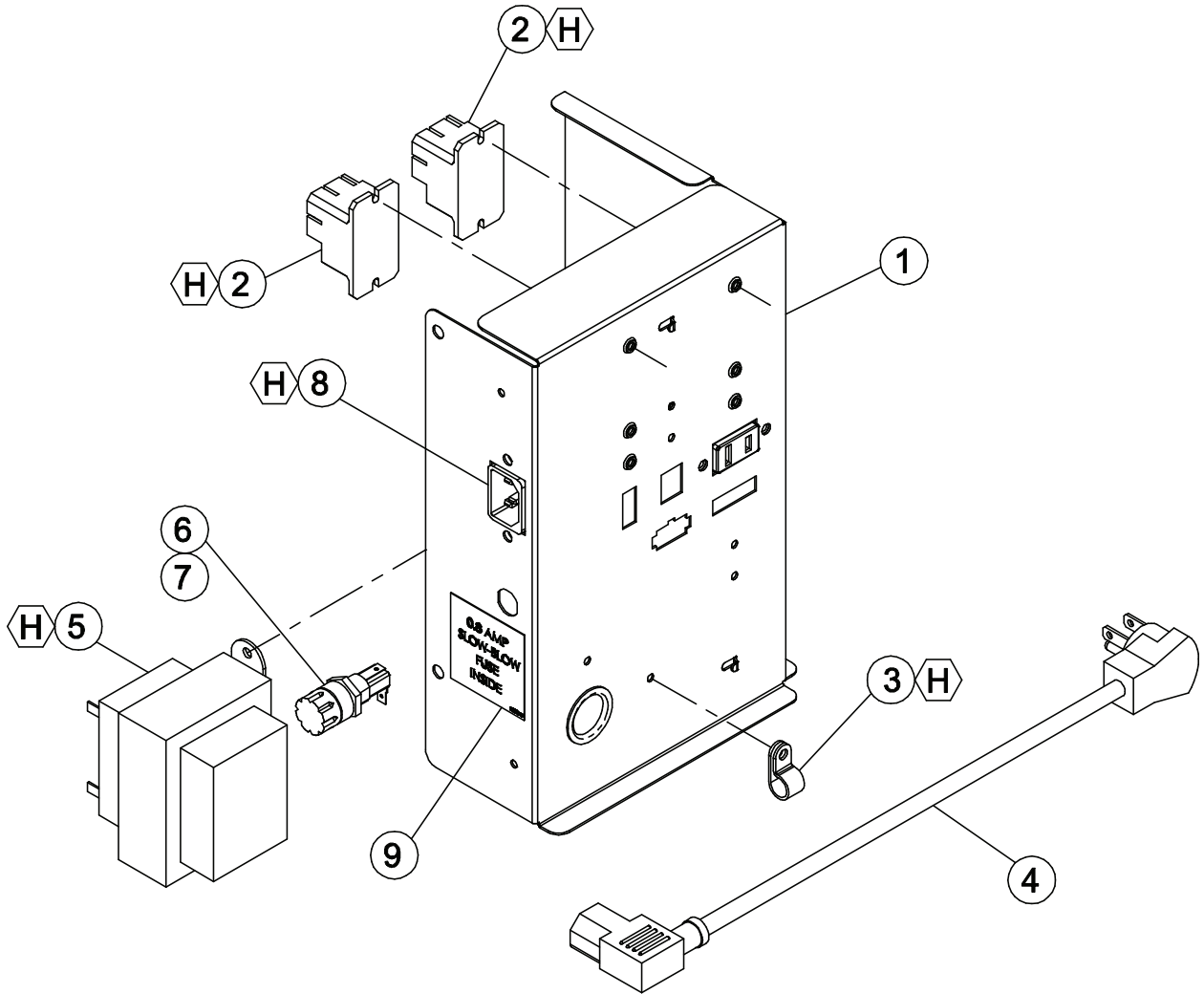



POWER BOX ASSEMBLY

ITEM NO	DESCRIPTION	QTY REQ	PART NO.
1	POWER BOX HOUSING	1	1123448
2	RELAY	2	1124284
3	CLAMP	1	324099-3
4	CORDSET	1	1124281
5	TRANSFORMER	1	1111201
6	FUSEHOLDER	1	387966
7	0.8 AMP FUSE (NOT SHOWN)	1	1053864
8	POWER HARNESS	1	1123444
9	FUSE LABEL	1	1089546



VENDO HARNESS QUICK REFERENCE GUIDE TRADE VENDORS

PART NO.	DESCRIPTION	PURPOSE	721	821	621
1122905	Door Harness	Connects motors, temp. sensors, transformer, drop sensors, and relays to the control board	X	X	X
1111287	Selection Harness - 10 select	Connects the selection buttons to the control board	X	X	N/A
1117872	Selection Harness - 8 select	Connects the selection buttons to the control board	N/A	N/A	X
1111252	Display Harness	Connects the display to the control board	X	X	X
1122918	Motor Harness - 10 select	Connects the vend motors to the door harness	X	X	N/A
1123050	Motor Harness - 8 select	Connects the vend motors to the door harness	N/A	N/A	X
1122193	Evaporator Fan Harness	Connects the evaporator fans to the power distribution box	X	X	X
1123444	Power Distribution Harness	Input for 110v service cord and output to compressor, evaporator, fans, control board, and transformer	X	X	X
1124065	Motor Harness w/ Pre-cool - 10 select	Connects the vend motors to the door harness	X	X	N/A
1124066	Motor Harness w/ Pre-cool - 8 select	Connects the vend motors to the door harness	N/A	N/A	X



NOTES



TRADE DOOR SECTION

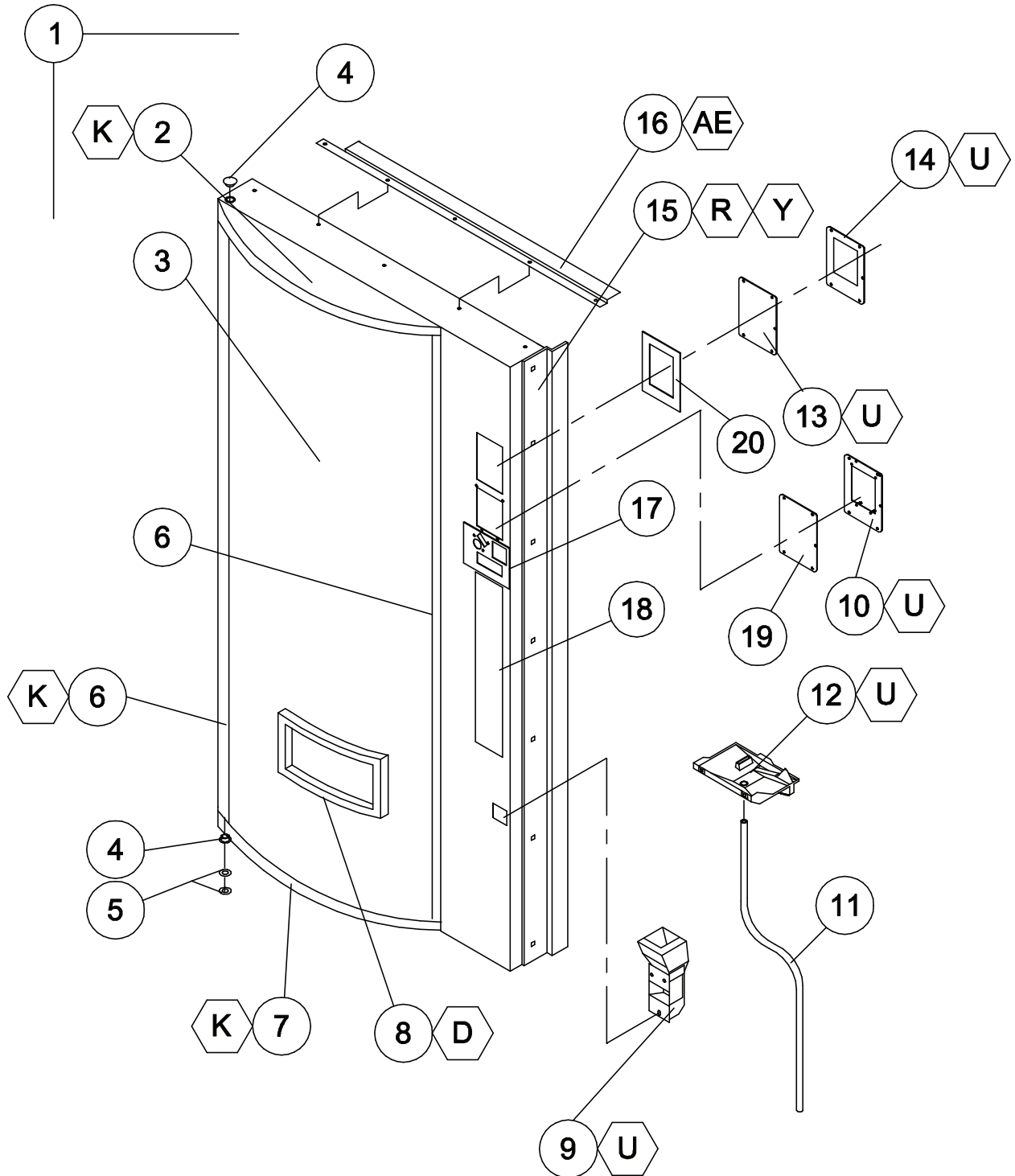



V21 TRADE OUTER DOOR - CURVED

ITEM NO	MODEL NUMBER		721	821
	DESCRIPTION	QTY REQ	PART NO.	PART NO.
*1	OUTER DOOR ASSEMBLY	1	1112619-43	1112627-15
2	SIGN CAP - TOP	1	1014986	1014986
**3	SIGN FACE	1	**	**
4	BUSHING HINGE	2	388094	388094
5	FLAT WASHER 3/8" - BOTTOM	2	V801491	V801491
6	SIGN TRIM - LEFT AND RIGHT	2	388125-2B	388125B
7	SIGN CAP - BOTTOM	1	1068988	1068988
8	EYELET TRIM	1	388271	388271
9	COIN RETURN CUP	1	1079546	1079546
10	DBV PLUG PLATE	1	2000856	2000856
11	DRAIN TUBE	1	1110619	1110619
12	WATER COLLECTION PLATE	1	1110562	1110562
13	DBV PLUG PLATE - UPPER	1	1089597	1089597
14	DBV MOUNT PLATE - UPPER	1	1089619	1089619
15	DOOR GUARD	1	2010131	2009503
16	RAIN GUARD	1	2000848	2000848
17	LOCK ASSEMBLY (SEE PAGE TD-8 - TD-9)	1	~	~
18	SELECTION PANEL (SEE PAGE TD-10 - TD-11)	1	~	~
19	DBV GASKET - LOWER	1	1086759	1086759
20	DBV GASKET - UPPER	1	1120606	1120606

* NOTE: WHEN ORDERING OUTER DOOR ASSEMBLY, PLEASE PROVIDE **9-CODE** OR **11-CODE** AND **MANUFACTURER'S DATE CODE**.

NOTE: WHEN ORDERING SIGN FACE, PLEASE PROVIDE **FRANCHISE AND **STYLE**.

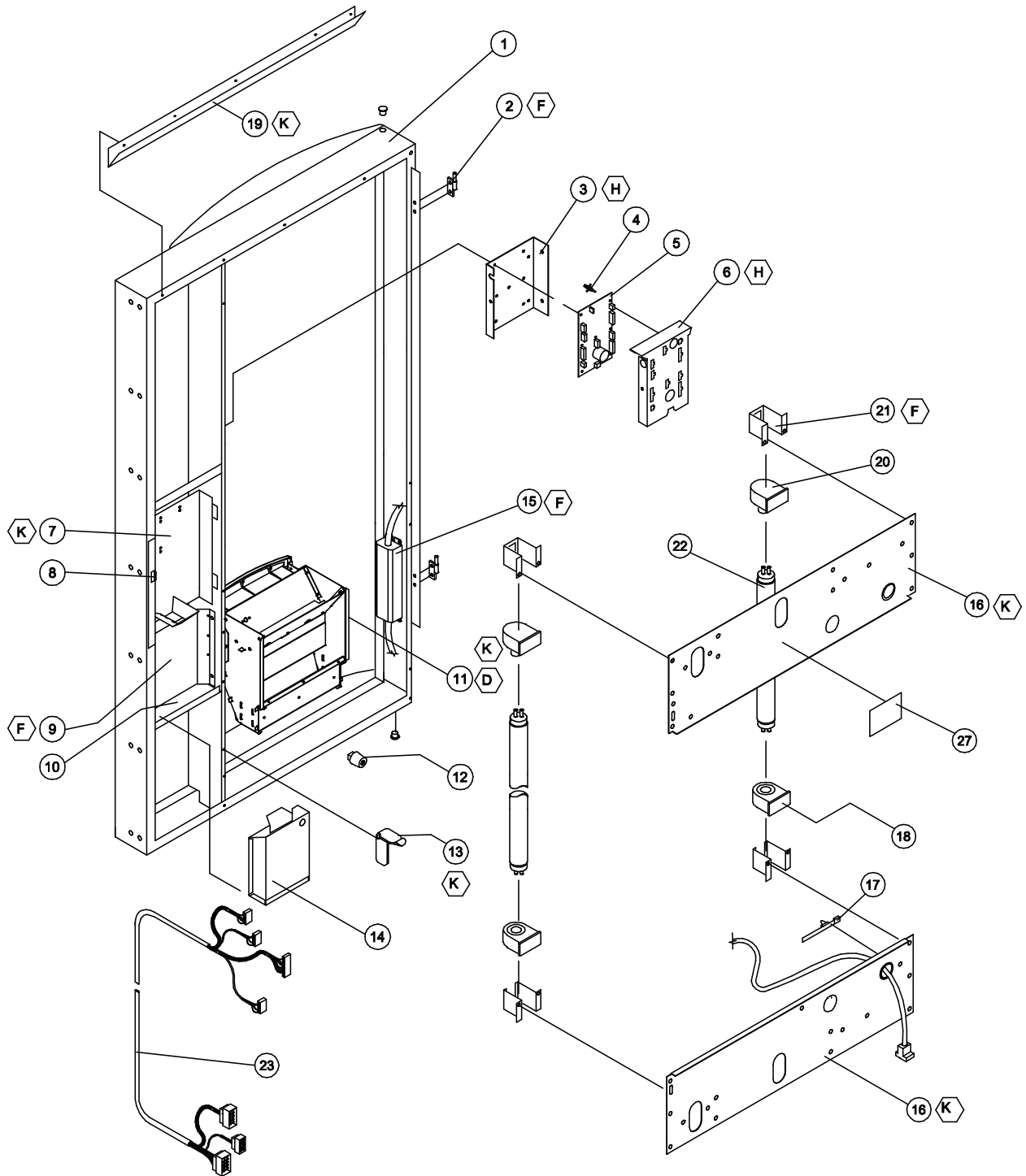



V21 TRADE OUTER DOOR - CURVED (CONTINUED)

ITEM NO	MODEL NUMBER		721
	DESCRIPTION	QTY REQ	PART NO.
1	DOOR WELD - BLACK	1	1123712
2	HINGE - INNER DOOR, MALE	2	1121287
3	MOUNTING BRACKET - CONTROLLER	1	1077716
4	STAND OFF	7	1121740
5	PCBA VEC 12.1 CONTROLLER	1	1123051-12.1
6	COVER PANEL	1	1123049
7	COIN DOOR ASSEMBLY	1	1081112
8	LATCH - COINAGE DOOR	1	1085546
9	BARRIER PANEL	1	1117147
10	BULKHEAD COIN BOX SUPPORT	1	1112155
11	DELIVERY HOPPER ASSEMBLY	1	1124162
12	DOOR BUMPER	2	1036912
13	RAMP/CATCH - INNER DOOR	1	1121714
14	COIN BOX ASSEMBLY	1	133563
15	BALLAST 115V	1	1122380
16	SHEAR PANEL - LOWER/UPPER	2	1123915
17	HARNESS TIE	3	1045474
18	LAMP HOLDER - FIXED, MEDIUM BI-PIN	2	388531
19	RAIN GUTTER	1	1121204
20	LAMP HOLDER - PLUNGER, MEDIUM BI-PIN	2	388532
21	BRACKET - LAMPHOLDER	4	1122305
22	LAMP - FO40W T-8	2	1121733
23	DOOR HARNESS	1	1122905
24	RAIN CURTAIN, BALLAST (NOT PICTURED)	1	1121837
25	RAIN CURTAIN, LIGHTS (NOT PICTURED)	2	1121838-1
26	MDB HARNESS (NOT PICTURED)	1	1124570
27	LABEL, CAUTION, T-8 LAMPS ONLY	1	1122973

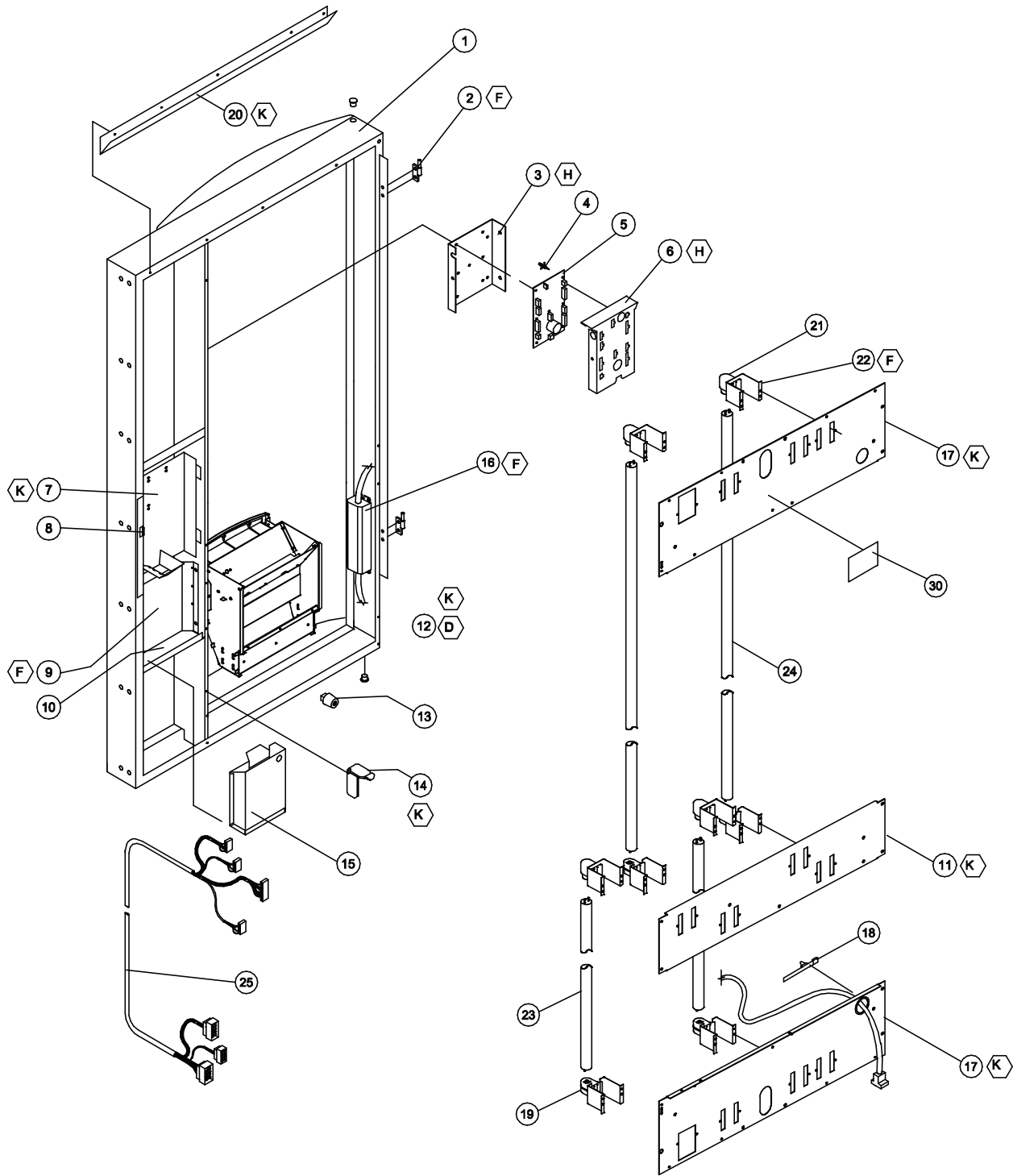



V21 TRADE OUTER DOOR - CURVED (CONTINUED)

ITEM NO	MODEL NUMBER		821
	DESCRIPTION	QTY REQ	PART NO.
1	DOOR WELD - BLACK	1	1123713
2	HINGE - INNER DOOR, MALE	2	1121287
3	MOUNTING BRACKET - CONTROLLER	1	1077716
4	STAND OFF	7	1121740
5	PCBA VEC 12.1 CONTROLLER	1	1123051-12.1
6	COVER PANEL	1	1123049
7	COIN DOOR ASSEMBLY	1	1081112
8	LATCH - COINAGE DOOR	1	1085546
9	BARRIER PANEL	1	1117147
10	BULKHEAD COIN BOX SUPPORT	1	1112155
11	SHEAR PANEL - MIDDLE, 4-BULB T-8	1	1122308
12	DELIVERY HOPPER ASSEMBLY	1	1123728
13	DOOR BUMPER	2	1036912
14	RAMP/CATCH - INNER DOOR	1	1121714
15	COIN BOX ASSEMBLY	1	133563
16	BALLAST 120V, 68-128W T-8	1	1122380
17	SHEAR PANEL - LOWER/UPPER, 4-BULB T-8	2	1122268
18	HARNESS TIE	3	1045474
19	LAMP HOLDER - FIXED, MEDIUM BI-PIN	4	388531
20	RAIN GUTTER	1	1121204
21	LAMP HOLDER - PLUNGER, MEDIUM BI-PIN	4	388532
22	BRACKET - LAMPHOLDER	8	1122305
23	LAMP - 17W T-8, 24"	2	1121173
24	LAMP - 32W T-8, 48"	2	1121173-2
25	DOOR HARNESS	1	1122905
26	RAIN CURTAIN, BALLAST (NOT PICTURED)	1	1121837
27	RAIN CURTAIN, LIGHTS (NOT PICTURED)	2	1121838-1
28	MDB HARNESS (NOT PICTURED)	1	1124570
29	LABEL, CAUTION, T-8 LAMPS ONLY	1	1122973

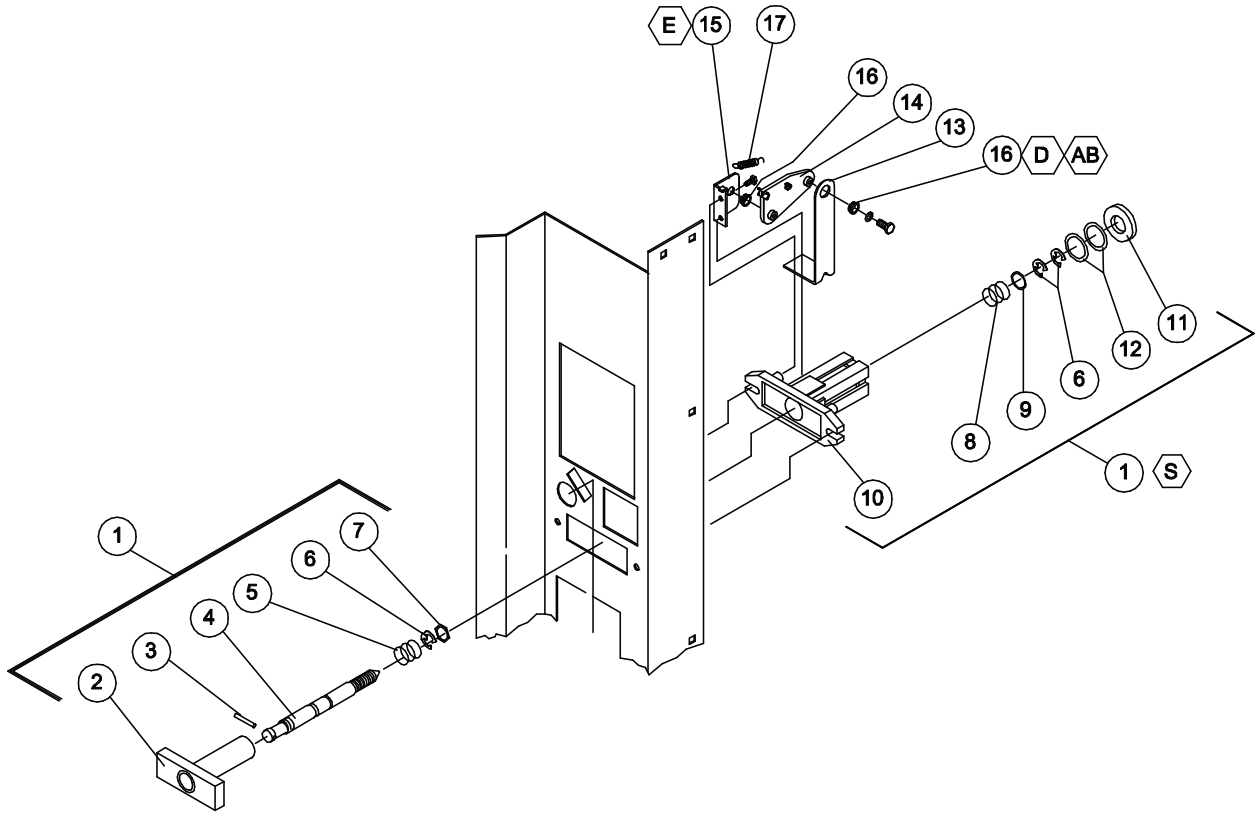



V21 TRADE LOCK ASSEMBLY

ITEM NO	DESCRIPTION	QTY REQ	PART NO.
1	LOCK ASSEMBLY - QUICKER LOCK	1	1002635
2	T-HANDLE	1	1002392
3	PIN - STUD	1	387601
4	LOCK STUD - QUICKER LOCK	1	1049724
5	SPRING	1	389691
6	E-RING RETAINER	3	388589
7	HEX WASHER	1	387600
8	SPRING - HEAVY	1	389691
9	FLAT WASHER	1	387718
10	FLANGE	1	1002384
11	VAPOR SEAL	1	388132
12	WASHER 1/2	2	V801023
13	LEVER - COIN RETURN	1	1052619
14	CRANK - COIN RETURN LEVER	1	1002244
15	PIVOT BRACKET - COIN RETURN	1	1002252
16	BUSHING	2	385603-4
17	SPRING - COIN RETURN LEVER	1	1060023

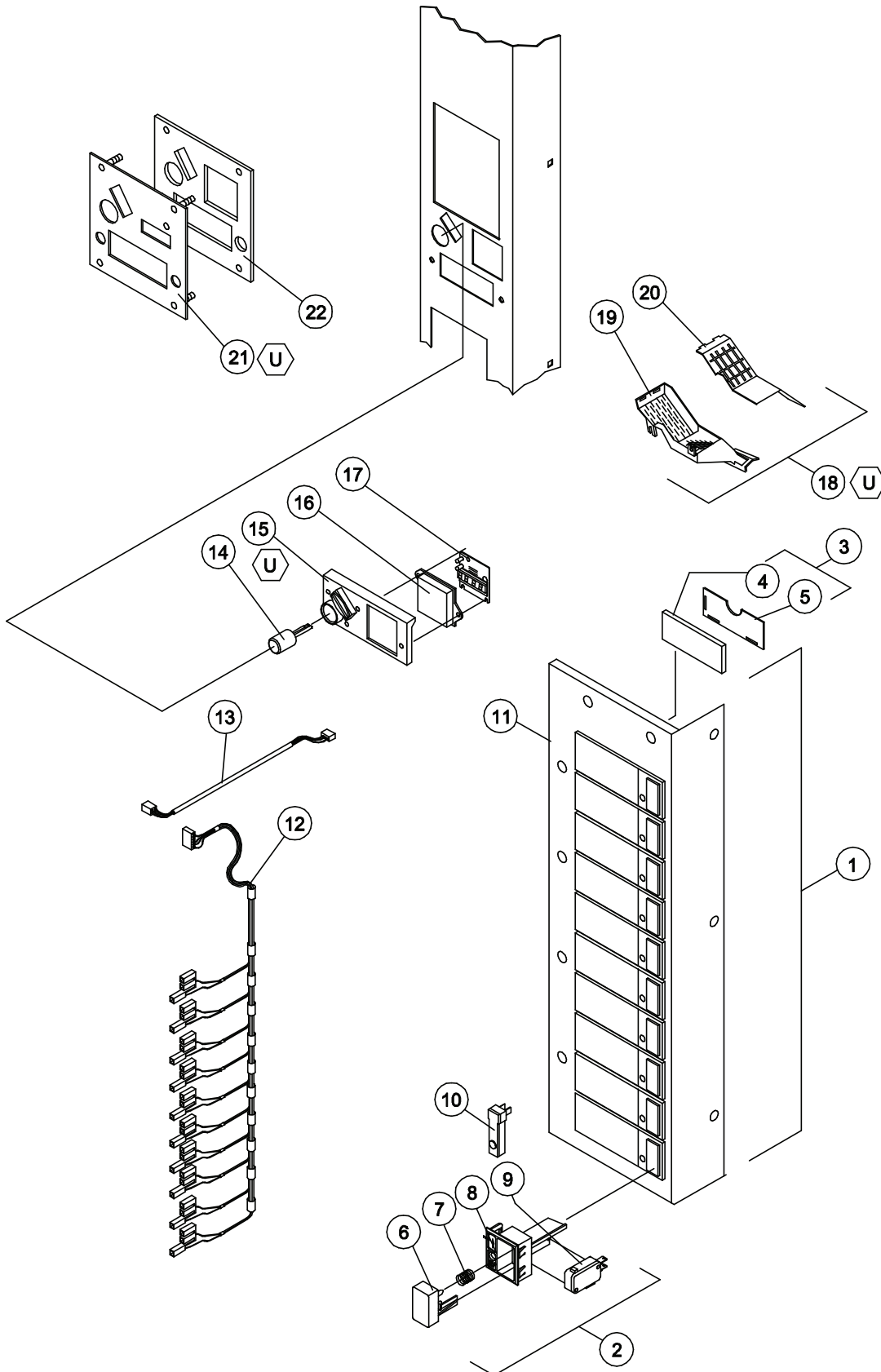

TD-10



V21 TRADE SELECTION PANEL

ITEM NO	DESCRIPTION	QTY REQ	PART NO.
1	SELECTION PANEL ASSEMBLY - TRADE CURVE/FLAT (10 SELECT)	1	1011766-42
2	SELECTION WINDOW & BUTTON ASSEMBLY	10	1036203
3	SELECTION WINDOW ASSEMBLY	10	133431
4	SELECTION WINDOW	10	388223
5	SELECTION WINDOW - BACK	10	388116
6	SELECTION BUTTON	10	1116775
7	SELECTION SPRING	10	388858
8	BUTTON HOUSING	10	1006932
9	SELECTION SWITCH	10	368299
10	SOLD-OUT PLUG	10	1006975-1
11	SELECTION PANEL - 10 SELECT	1	2010158
12	SELECTION HARNESS - 10 SELECT	1	1111287
13	DISPLAY HARNESS	1	1111252
14	COIN RETURN BUTTON	1	1050473
15	COIN INSERT/RETURN GUIDE PLATE	1	1050481
16	DISPLAY LENS	1	1039652
17	DIGITAL DISPLAY PCB - ELECTRONIC	1	1089678
18	COIN CHUTE ASSEMBLY	1	1034154
19	COIN CHUTE	1	1002333
20	CHUTE COVER	1	1002341
21*	COIN INSERT PLATE	1	--
22	COIN INSERT SECURITY PLATE	1	2001481

* NOTE: WHEN ORDERING COIN INSERT PLATE, PLEASE SPECIFY **STYLE**.

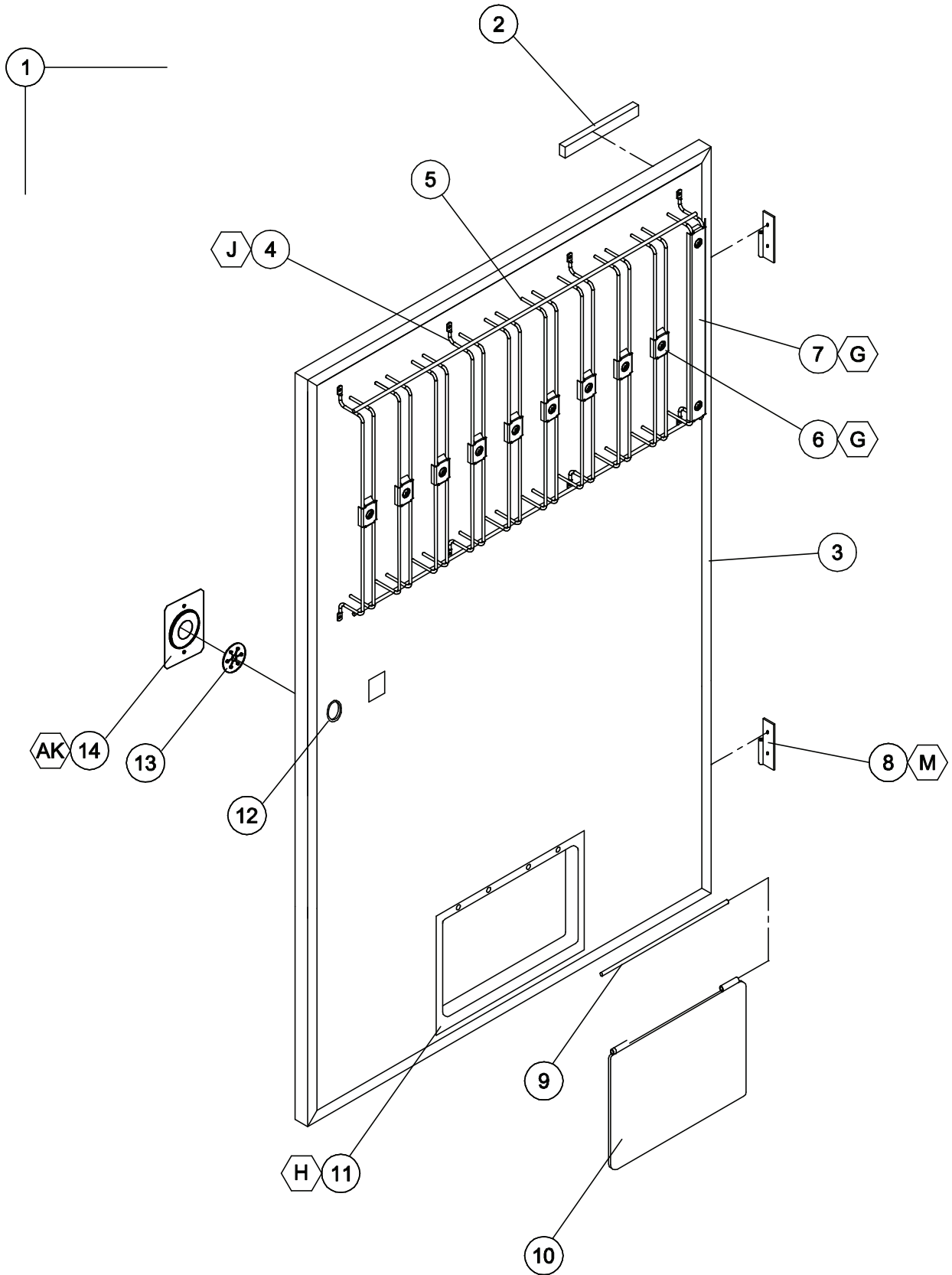

TD-12

01/2003



V21 TRADE INNER DOOR

ITEM NO	MODEL NUMBER		721	821
	DESCRIPTION	QTY REQ	PART NO.	PART NO.
1	INNER DOOR ASSEMBLY	1	134302-103	134302-104
2	RAIN SEAL, INNER DOOR, 7"	1	1111732-2	1111732-2
3	INNER DOOR SEAL	1	1075678	1075678-1
4	UPPER PRODUCT RETAINER ASSEMBLY	1	1125206-1	1125206-2
5	UPPER PRODUCT RETAINER	1	1124285	1124285-1
6	SHORT CLIP ASSEMBLY	9	1125261	1125261
7	LONG CLIP ASSEMBLY	1	1125262	1125263
8	INNER DOOR HINGE, FEMALE	2	1121286	1121286
9	HINGE PIN	1	389985	389985
10	REVERSABLE VEND FLAP	1	1013076	1013076
11	INNER DOOR EYELET	1	387273	387273
12	GROMMET	1	388090	388090
13	INNER DOOR LATCH	1	1121711	1121711
14	INNER DOOR LATCH BRACKET	1	1121712	1121712

V21 TRADE INNER DOOR LABELS - NOT SHOWN

DESCRIPTION	QTY REQ	PART NO.
ERROR CODE LABEL, VEC 12.1	1	1123715
PROGRAMMING LABEL, VEC 12.1	1	1123343
WIRING DIAGRAM LABEL, VEC 12.1/12.2	1	1124295
PRODUCT SET UP, V21	1	1124035
SPACE TO SALES, VEC 12.1	1	1122286



NOTES



MAINTENANCE SECTION



MAINTENANCE

The following section is a basic guide for general maintenance and servicing of the vendor. This section is divided into three parts: (I) Preventative Maintenance, (II) Lubrication Guide, and (III) Care and Cleaning.

I. PREVENTATIVE MAINTENANCE SUGGESTIONS:

Whenever a vendor is visited on its site, the following service should be performed. Preventative maintenance will help prevent future problems with the vendor.

- A. Observe the vendor and its surrounding area for any unusual indications of problems (rear of cabinet, obstructions of the air flow, dark spots on the sign face, etc.).
- B. Open the door and visually check the inside of the vendor (water accumulation, rust marks, moisture around the edges of the inner door, etc.).
- C. Check the fluorescent lamps, replace as necessary. Replace all lamps within 24 to 48 hours of burnout. This will prevent damage to the ballast.
- D. Check the product temperature for proper cooling.
- E. Check the evaporator drain for obstruction; water in the evaporator area must drain to the condensation pan.
- F. Empty condensation pan.
- G. Clean the condenser filter.
- H. Check that evaporator fan runs normally.
- I. Check that the compressor and condenser fan run normally.
- J. Investigate any unusual sounds (fan blades hitting something, refrigeration lines rattling, etc.).
- K. Clean coin acceptor.
- L. Check for proper operation of the coinage mechanism by inserting all denominations of coins accepted by the vendor.
- M. Test the vendor and make a report on the problems.

II. LUBRICATION GUIDE:

Lubricate indicated areas as directed on the chart below.

INTERVALS	PARTS	LUBRICANT
Every six months	Top door hinge, hinge pin at the base of cabinet, door latch cam to cabinet strike, T-handle shaft & latch.	Grade two, high low temperature grease
As necessary	Pivot area of bucket and gate	Grade two, high low temperature grease



III. CARE AND CLEANING

DO NOT USE WATER JET FOR CLEANING.

AVOID USING WATER OR ANY OTHER LIQUIDS NEAR ELECTRONIC COMPONENTS

- A. GENERAL PROCEDURE (painted metal areas)
Wash the vendor with soap and water. The exterior may be waxed with any good automobile wax.
- B. FRESH PAINT SPLASHES, GREASE, GLAZING COMPOUND REMOVAL
Before drying, these elements may be removed by rubbing lightly with grade "A" Naptha (or equivalent grade solvent). After removal, use general cleaning procedure (listed above in A).
- C. LABELS AND STICKER REMOVAL
Use any specialized label removal liquid. When the label material does not allow penetration of solvent (such as vinyl), the application of heat (ie – hot air gun) will soften the adhesive and promote removal. **CAUTION:** Excessive heat can cause surface damage. After the label is removed, use the general cleaning procedure (listed above in A).
- D. SCRATCH REMOVAL
Remove or minimize hairline scratches and minor abrasions by using any good quality automobile polish. Test product before using.
- E. LEXAN SIGNS
To clean Lexan sign faces the following procedure is recommended.
1. Wash sign with mild soap or detergent and lukewarm water.
 2. Using a soft cloth or sponge, gently wash the sign. **DO NOT SCRUB!**
 3. Rinse well with clean lukewarm water.
 4. Dry thoroughly with a chamois or cellulose sponge (to prevent water spotting). **DO NOT USE SQUEEGEE!**
- NOTE:** Most organic solvents, petroleum, spirits, or alcohol are **NOT** compatible cleaning materials for Lexan signs. Usage of those materials could permanently damage the sign.
- F. REFRIGERATION AREA
The condenser and evaporator must be kept clean for efficient operation. Be sure all vanes and tubing are clean and clear of obstruction; this allows free passage of air. Clean with a brush, a vacuum cleaner or compressed air, using extreme caution not to bend the condenser vanes. Keep cabinet drain open; clean as necessary.



REFRIGERATION OPERATION

The refrigeration operation section is divided into three areas: Basic Refrigeration Principle, Detailed Vending Machine Refrigeration Cycle, and Parts Description.

BASIC REFRIGERATION PRINCIPLE

What a refrigeration system really accomplishes is the transfer of heat. A refrigeration system removes the excess heat from a refrigerated area and then transfers it to a condenser where it is dissipated. As heat is removed, the refrigerated area cools.

In vending machines, large quantities of the heat must be transferred rapidly, economically and efficiently. This process must be able to withstand continuous repetition, without loss of refrigerant, over an extended period. The most common system used in the vending industry is the vapor compression (or simple compression) cycle system. It consists of four basic elements: An evaporator, a compressor, a condenser, and a pressure-reducing device (all part of a sealed system).

The compression system operates at two pressure levels: The low evaporating pressure and the high condensing pressure. The refrigerant acts as the transport medium, in which heat is moved from the evaporator to the condenser; at the condenser, the heat is dissipated into the surrounding air.

The liquid refrigerant changes from a liquid to a vapor and back to a liquid again. This change of state allows the refrigerant to absorb, and rapidly discharge, large quantities of heat efficiently.

BASIC VAPOR COMPRESSION SYSTEM CYCLE:

In the evaporator, the liquid refrigerant vaporizes. This change occurs at a temperature low enough to absorb heat from the refrigerated space. The temperature of vaporization is controlled by the pressure maintained in the evaporator (the higher the pressure, the higher the vaporization point).

The compressor pumps the vapor from the evaporator, through the suction line, and to the condenser. The compressor takes the low pressure vapor and compresses it, increasing both the pressure and the temperature. The compressor pumps the vapor at a rate rapid enough to maintain the ideal pressure. The hot, high pressure vapor is forced out of the compressor, into the discharge line and then into the condenser.

Air is blown through the condenser, allowing heat to transfer from the condenser and into the passing air. As the heat is removed, the stored refrigerant is condensed into a liquid. The liquid refrigerant is stored in the lower tube of the condenser. This is where it flows through the capillary tube back into the evaporator, where the refrigeration cycle is repeated.



DETAILED REFRIGERATION CYCLE

The following is a detailed refrigeration cycle as it applies to the refrigeration system installed in Vendo equipment. (Refer to the flow chart in Figure 1.)

As the air temperature in the cabinet rises, the electronic temperature sensor reports the air temperature to the electronic controller. The electronic controller actuates the refrigeration control relay, which turns on both the compressor and condenser fan motor.

The evaporator fan pulls air from the front of the refrigerated space of the cabinet. It pulls the air through the evaporator, and blows it up the rear of the vend stack. (The evaporator fan runs continuously.) As the air passes through the evaporator, heat is drawn from the air and transferred to the liquid refrigerant. As the cooled air circulates through the vend stack, heat is drawn from the product and transferred to the circulating air. The heated air is again drawn through the evaporator where the heat is removed.

In the evaporator, the liquid refrigerant draws heat from the circulating air. As refrigerant receives heat, it vaporizes.

The compressor pumps the vapor from the evaporator and compresses it, increasing both pressure and temperature. The compressor forces the compressed vapor out, through the discharge line and into the condenser.

The condenser fan pulls air through the condenser. As the hot refrigerant vapor passes through the condenser tubes, heat is drawn from the vapor. This heat is dissipated into the passing air. The air then exits out the back of the vendor. As the refrigerant vapor in the condenser lines is cooled, it returns to a liquid state.

From the condenser the liquid flows to the drier. The drier removes any water and solid particles from the liquid refrigerant.

The cooled liquid refrigerant continues from the drier, through the capillary tube, to the evaporator. The capillary tube steadies the flow rate of the refrigerant. Its small inside diameter allows the pressure in the evaporator to remain low while the pressure in the condenser is high.

The cool refrigerant in the evaporator draws heat from the circulating air in the cabinet. As the temperature in the cabinet drops, the electronic temperature sensor reports the air temperature to the electronic controller. The electronic controller deactivates the refrigeration control relay, which turns off the compressor and condenser fan motor.

When the air temperature in the cabinet rises above the electronic controller's cut in setting, the compressor and the condenser fan engage again.

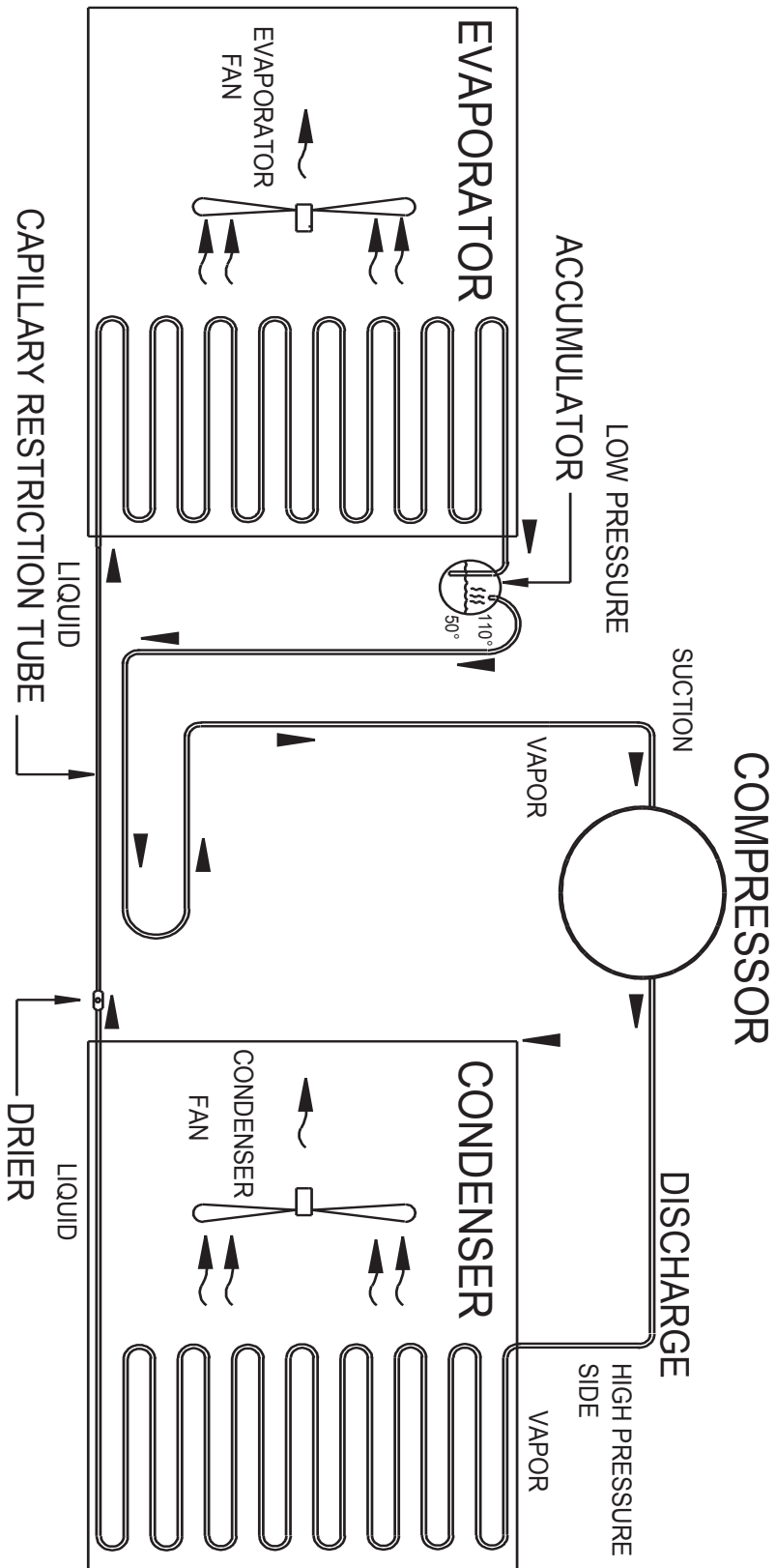

FIGURE 1



REFRIGERATION PARTS DESCRIPTION

The compressor, condenser, drier, capillary tube, evaporator, and accumulator are part of a sealed system (refer to Figure 2). These items are not available separately.

COMPRESSOR

The compressor takes in low pressure vapor and compresses it, increasing both the pressure and the temperature. The hot, high pressure gas is forced out to the condenser. The compressor and the motor that drives the compressor are sealed inside a housing. The compressor, as a unit, is mounted on the refrigeration base. The base is mounted in the bottom of the vendor, outside the sealed refrigeration space.

CONDENSER

The condenser takes heat out of the high pressure vapor that it receives from the compressor. As the vapor passes through the condenser it cools and returns to a liquid state. The condenser is mounted to the refrigeration base near the front of the vendor. It is easily accessible for cleaning.

DRIER

The drier is a molecular sieve strainer drier. It removes water and solid particles from refrigerant liquid. One side of the drier is connected to the outlet line of the condenser; the other side is connected to the capillary tube going to the evaporator.

CAPILLARY TUBE

The capillary tube controls, at a steady rate, the flow of refrigerant liquid to the evaporator. It has a very small inside diameter to keep pressure in the evaporator low while the pressure in the condenser is high. It is the connecting link between the condenser and evaporator.

EVAPORATOR

The evaporator is a heat transference device. It removes the heat from the air in a refrigerated space and transfers it to the refrigerant liquid. This liquid evaporates into a vapor and is removed by the compressor. The evaporator is mounted inside the refrigerated space of the cabinet, directly below the delivery chute.

ACCUMULATOR

The accumulator traps any refrigerant liquid, which did not boil off into a vapor before reaching the compressor. The accumulator allows the refrigerant liquid to boil off as a vapor (preventing damage to the compressor). It also prevents suction line sweating. The accumulator is mounted in the suction line on the outline side of the evaporator.

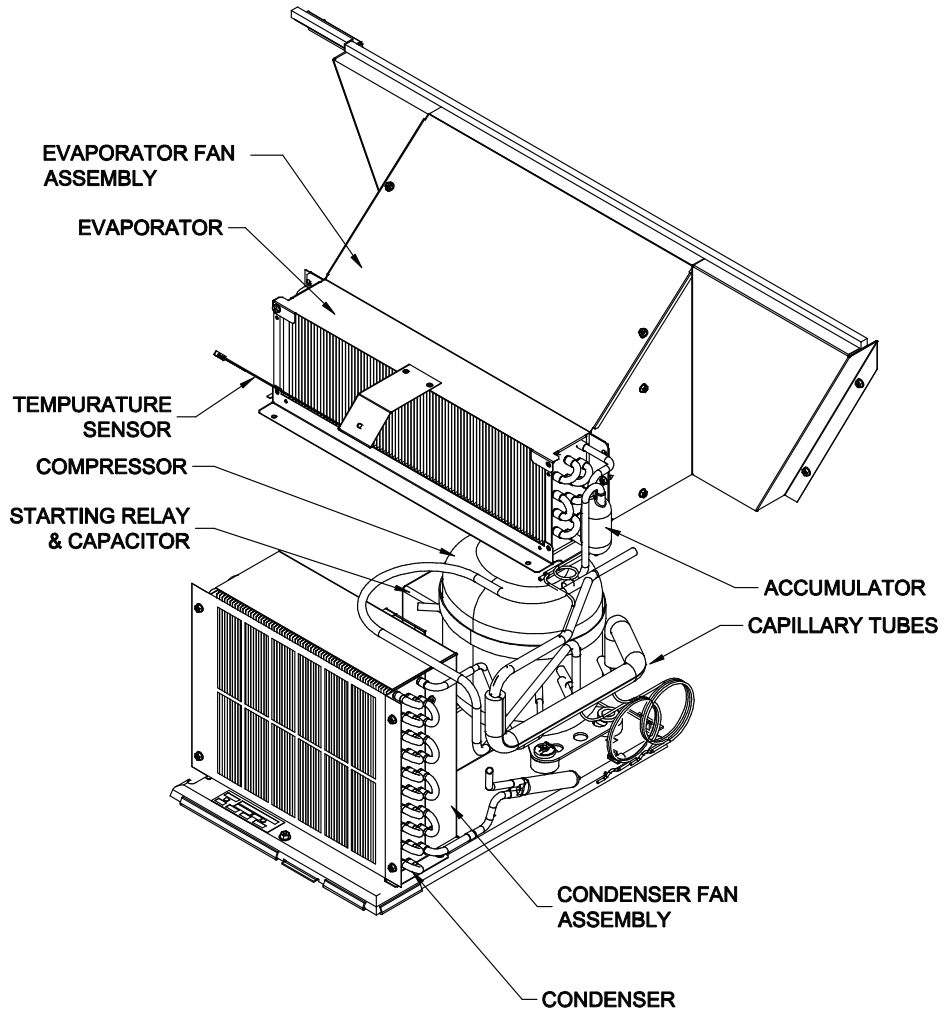

FIGURE 2



The parts listed below are not part of the sealed refrigeration system and are available separately.

START CAPACITOR - P/N: 1112805

The start capacitor is used to increase power during the start. This additional power will help get the compressor running in case there is any back pressure.

STARTING RELAY – INCLUDED IN ASSEMBLY P/N 513506066

The starting relay is mounted in the terminal box on the outside of the compressor under the housing. When the compressor first starts up, the starting relay closes and completes a starting circuit. When the compressor motor reaches operating speed, the starting relay opens and breaks the starting circuit.

THERMAL OVERLOAD SWITCH – INCLUDED IN ASSEMBLY P/N 513506066

The thermal overload switch is mounted in the terminal box on the outside of the compressor under the housing. If the compressor motor gets hot or draws too much current, the thermal overload opens and breaks the starting and running circuit of the motor. As the motor cools, the thermal overload closes, allowing the compressor to restart.

TEMPERATURE SENSOR – P/N 1122924

The temperature sensor is mounted in the inlet airflow of the evaporator. This monitors the air temperature and reports it to the electronic controller so that the controller can operate the refrigeration system via the power box.



NOTES



TROUBLESHOOTING SECTION



**THE VENDO COMPANY
NEW EQUIPMENT WARRANTY
V-MAX & V21 VENDING MACHINES
Distributor North America/ Canada**

- I. This warranty benefits each current owner of a V-Max or V21 vending machine, whether that owner is the original purchaser or a transferee.
- II. The Vendo Company warrants each part of each new vending machine for a period of fifteen (15) months from the date of shipment, to be free from defects in material and workmanship. This Warranty DOES NOT include light bulbs, fluorescent tubes, fuses, finish or operating supplies.
- III. The hermetically-sealed refrigeration system used in machines designed to vend bottles, cans, and aseptic cartons is warranted to be free from defects in materials and workmanship for six (6) years, provided the hermetically-sealed portion of the system has not been opened or damaged. This six (6) year warranty DOES NOT include fan motors, temperature controls, capacitors, overload switches or starting relays.
- IV. Electronic control boards, LED displays and Vend motors, are warranted against defects in material and workmanship for five (5) years.
- V. Return authorization is required to qualify for warranty replacement. All requests for returns must be in writing or via phone, within the warranty period, and accompanied by a record of the cabinet model and serial number of the machine. Freight carrier return tickets will only be issued to the machine owner for refrigeration system returns. This warranty is voided when the serial number of a machine is missing. If a return is found to be inoperative due to defects in material and/or workmanship, we will, at our option, make necessary repairs or furnish a reconditioned or new replacement part or refrigeration system at no charge.
- VI. "Return Material Tags" indicating cabinet model, machine serial number and explanation of defect must accompany all returned parts or machines. "Return Material Tags" will be furnished upon request. On-site inspection of defective parts, at The Vendo Company's option, may be used to facilitate credit approval or the replacement of parts.
- VII. The Vendo Company will pay normal transportation charges on refrigeration systems and parts replaced under this warranty. If special handling or premium transportation is requested, those charges will be assumed by the machine owner.
- VIII. Any parts and/or refrigeration systems replaced during the warranty period are warranted for the remaining time on the original warranty
- IX. This warranty DOES NOT apply to machines located outside the United States and Canada, reconditioned equipment, equipment sold "as is", or components designed to work on electric currents other than 110v/120hz 60 cycle or 208v/220hz 50 cycle, as specified on the serial tag.
- X. Title and risk of loss pass to the machine owner on delivery of the vending machine, replacement parts and/or refrigeration system to the common carrier. All loss and damage claims are the responsibility of the machine owner and must be filed with the delivering carrier.
- XI. This warranty DOES NOT include any service guarantee, either explicit or implied, nor will it extend to cover incidental or consequential damages resulting from purchaser or third party negligence, accident, vandalism, or an act of God.
- XII. The Vendo Company reserves the right to make design changes, additions to, and improvements upon any of our product without incurring any obligation to incorporate same on any product previously manufactured.
- XIII. This warranty is in lieu of all other express warranties or other obligations or liabilities on our part, and we neither assume nor authorize any person to assume for us, any other obligation for liability in connection with the sale of said machines or parts thereof. EXCEPT AS SPECIFICALLY PROVIDED HEREIN, THERE ARE NO WARRANTIES GIVEN, EITHER EXPRESS OR IMPLIED, AND ALL OTHER WARRANTIES, INCLUDING SPECIFICALLY BUT WITHOUT LIMITATION WARRANTIES OF MERCHANTABILITY AND FITNESS FOR PARTICULAR PURPOSE, ARE HEREBY EXPRESSLY DISCLAIMED.



PARTS RETURN PROCEDURES

1. All parts returned must be accompanied by a material return tags (P/N 1122825) Tag must clearly state the reason for the return and the Return Goods Authorization Number received from your Vendo Customer Service Rep at 1-800-344-7216. (Return tags are available from our parts department upon request).
2. All parts should be properly wrapped and packed securely to avoid further damage.
3. To replace an inoperative part, please use the following instructions
4. Complete the return tag making sure to fill in ALL requested information to ensure prompt processing. Keep top (white) copy for your records. Attach tag to inoperative part and send it by the most inexpensive method of transportation (Federal Express Ground or Overnight Transportation) **To: THE VENDO COMPANY, 4015 EAST RAINES ROAD, MEMPHIS, TENNESSEE 38118.**
5. Be sure to check () the box marked "credit" and to fill in the invoice number covering the part sent to you or check the box marked "replace with like part".
6. If the box is marked for replace with like part, a like part will be shipped at no charge if our inspection shows that the inoperative part became defective during the warranty period.
7. If the box is marked for credit, a credit will be issued to cancel the invoice on which the replacement part was shipped. This credit will include any applicable prepaid transportation charges. To receive credit the inoperative part must be returned within 30 days from the date the replacement was shipped.
8. Vendo does not issue cash credit for the return of any part or accessory.

REFRIGERATION UNIT RETURN PROCEDURE

1. All refrigeration units returned must be accompanied by a material return tag (P/N 1122826). Tag must clearly state the reason for the return and the Return Goods Authorization Number received from your Vendo Customer Service Rep at 1-800-344-7216. (Return tags are available from our parts department upon request).
2. All refrigeration units should be properly wrapped and packed securely to avoid further damage.
3. To replace an inoperative part, please use the following instructions.
4. Complete the return tag making sure to fill in ALL requested information to ensure prompt processing. Keep top (white) copy for your records. Attach tag to inoperative part and send it by the most inexpensive method of transportation (Federal Express Ground or Overnight Transportation) **To: THE VENDO COMPANY 7209 N. INGRAM AVE. FRESNO, CA. 93650**
5. Be sure to check () the box marked "credit" and to fill in the invoice number covering the part sent to you or check the box marked "replace with like part".
6. If the box is marked for replace with like part, a like part will be shipped at no charge if our inspection shows that the inoperative part became defective during the warranty period.
7. If the box is marked for credit, a credit will be issued to cancel the invoice on which the replacement part was shipped. This credit will include any applicable prepaid transportation charges. To receive credit the inoperative part must be returned within 30 days from the date the replacement was shipped.
8. Vendo does not issue cash credit for the return of any refrigeration unit.

***Canadian and International customers please contact your Customer Service Representative for return instructions**



Trouble Shooting Guide

The V21 vendor provides self-diagnostics to aid you in the trouble shooting process. Error codes are stored in the controller's memory when a system error is sensed. These codes can be accessed by following the procedure listed below.

The trouble shooting guide below contains information on how to solve problems with the 1) Vend system; 2) Refrigeration system; 3) Peripherals; 4) Selection switches; and 5) Miscellaneous problems. The guide is divided into subsections with these headers.

1. When the door is opened, the machine goes into "Door Open Data Retrieval" mode.
2. If there are any error states, the display will show "Error". If there are no recorded errors, the display will show "none".
3. If "Error" is displayed, press selection button two to enter the error diagnostics.
4. Pressing selection button one will scroll through the summary error codes (see appendix for detailed list).
5. To get greater detail on a particular error code, press selection button two.
6. While displaying a detailed error code, using selection button one (up/down), the controller shall cycle through all of the active detailed errors for the current summary level error code.
7. If selection button two (Enter) is pressed and held for 2 seconds during the display of any detailed error code, that detailed error code will be reset or cleared.
8. After clearing a displayed error code, either the next existing detailed error code, summary level error code, or the "nonE" message will be displayed, respectively.
9. If selection button three (Return) is pressed, the controller shall return to the summary level error code prompt.

Error	DESCRIPTION OF ERROR CODE	CHECKING METHOD	Corrective Action
Vending Mechanism			
CJnn	Column jam - vend cycle for column "nn" did not start or complete.	Look in column to see if product is jammed against gate or bucket.	Clear jam, complete a test vend cycle.
		Insure can clip is in correct position (reference set-up diagram).	Correct clip position, complete vend test.
		Insure bottles are loaded as shown in the Product Setup and Loading label.	Load bottles correctly.
CSn	Chute sensor error.	No test available.	Replace chute sensor assembly.
Selection Switches			
SSnn	Bad Selection Switch - Selection switch nn is actuated for more than 15 seconds while in the Customer Mode or Door Open Sales Test Mode.	Check the selection switch number shown in the detailed error code "nn" to see if: 1) the button is sticking; 2) the switch is sticking/defective; 3) the harness is wired wrong/shorted.	Try to correct the problem if one of the three items is found. If you can't correct it, then replace the component in question.
Space to Sales			
Ucnn	Column nn is not assigned to a selection.	Access space-to-sales mode and go to custom space-to-sales.	Change space-to-sales setting as required. In some situations, it may be quicker to completely reset all space-to-sales.
		Check all selections for the column shown in the detailed error description (nn).	



Error	DESCRIPTION OF ERROR CODE	CHECKING METHOD	Corrective Action
Usnn	Selection switch skipped - switch nn unassigned and a higher number switch is assigned.		Switch is assigned.
Coin Changer			
CC	Changer communication error - no changer communication for more than 2 seconds.	1) Check that red light is flashing on control board.	If light is not flashing, there is no power to board. Check and replug any unplugged connections.
			If fuse is blown replace it. Replace transformer.
		2) Defective acceptor.	Replace acceptor.
TtS	Tube sensor is defective -- reported by changer .	Check changer tubes for blockage.	Clear tube blockage. If no blockage is found, replace changer.
IC	Changer inlet chute blocked - no coins sensed for over 96 hours by the changer.	Check inlet chute for blockage. Drop coins to test acceptance. Manually clear the error.	Clear inlet chute blockage. If no blockage found, replace changer. If acceptance rate is acceptable, system is OK. If acceptance rate is low or changer will not accept coins, replace changer.
tJ	Tube pay out jam -- reported by changer.	Check changer tubes and payout for blockage.	Clear blockage, if found. If no blockage is found, replace changer.
CrCH	Changer check sum incorrect -- reported by changer.	Turn power switch off, wait at least five seconds, then turn on. Manually clear the error.	If error does not clear, replace changer/acceptor.
			Replace changer.
EE	Excessive escrow requests -- more than 255 requests since the last coin was sensed.	Check escrow lever and associated mechanisms.	Manually clear the lever and error.
		Close door then reopen. Check to see if error still occurs.	Replace changer/acceptor.
nJ	Coin jam - reported by changer.	Check changer/acceptor for jammed coins or other obstructions.	If no obstructions are apparent, replace changer/acceptor.
LA	Low acceptance rate -- coin acceptance has fallen below 80%.	Check changer/acceptor for obstructions or dirt.	If no obstructions are apparent, and acceptance appears to be OK, this may be an indication of cheating attempts.
		Drop coins to test acceptance.	If no obstructions are apparent and coins do not accept, or acceptance rate is poor, replace changer/acceptor.
diS	Disconnected acceptor -- indicates that an acceptor is unplugged.	Check coin mechanism plugs. Check for faulty harness wiring (see wiring diagram for circuit).	Correct connections.
rouT	Coin routing - indicates a coin was routed incorrectly.	Verify changer set-up using manufacturer's recommendations.	If acceptor was set up correctly, replace changer.



Error	DESCRIPTION OF ERROR CODE	CHECKING METHOD	Corrective Action
Dollar Bill Validator			
bC	Bill validator communications - No bill validator communication for 5 seconds.	If changer or card reader is being used, check for "CC" or "rC" errors.	If there are no "CC" or "rC" errors: 1) Check bill validator harness; 2) Replace bill validator. If there is a "C" or "rC" error: 1) Check control board MDB harness.
		Turn off door switch and wait at least five seconds. Turn on door switch.	
bFUL	Bill validator full - reported by validator (STACKER command).	Insure bill cashbox is empty and that the cashbox is properly closed and in place.	If cashbox appears to be OK, replace bill validator.
biLL	Bill validator motor is reported as defective by validator.	No test available.	Replace bill validator.
bJ	Bill jammed -- reported by validator.	Check bill validator for obstructions or dirt.	If no obstructions are apparent, replace bill validator.
brCH	Bill validator check sum is incorrect.	Turn power switch off. Wait at least five seconds. Turn power switch on. Manually clear the error.	If error does not clear, replace bill validator.
bOPn	Bill validator is open.	Check that bill cashbox is closed and in correct position.	If cashbox appears to be OK, replace bill validator.
bS	Bill validator sensor is not functioning.	Check bill validator for obstructions or dirt.	If no obstructions are apparent, replace bill validator.
Card Reader			
CrC	There is no card reader communication for 5 seconds.	If card reader/bill acceptor is being used, check for "rC" or "bC" errors.	If there is no "rC" or "bC" error: 1) Check changer harness. 2) Replace changer. If there is a "rC" or "bC" error: 3) Check control board MDB harness.
		Turn power switch off. Wait at least five seconds. Turn power switch on.	
CrXY	Most recent "non-transient error" from the card reader.	No test available.	Refer to card reader manual for corrective action.
Refrigeration			
SEnS	The temperature sensor is defective or unplugged.	Check to see that temperature sensor harness is plugged into door harness at air dam area.	If the sensor is unplugged, replug it.
		Check for temperature sensor connection J7 on control board is plugged in.	
CnPr	System has failed to decrease temperature 1° per hour while the compressor is running.	Access relay mode (refer to programming manual).	Refer to the refrigeration section on the following pages.
		Check refrigeration settings (refer to refrigeration section of programming manual).	Change settings as required.
Htr	Heater system has failed to increase temperature 1° per hour while heater is on.	Heater circuit not properly wired.	Check electrical connections.
		Bad sensor on heater circuit.	Replace sensor.
		Defective heating element.	Replace heating element.
Miscellaneous Problems			
ds	Door has been open for more than one hour.	Check the vendor's door switch to see if it's sticking or miswired.	Replace the door switch, if defective.
Ran	Ram check sum for service mode settings stored in non-volatile memory has been corrupted.	No test available.	If error shows up frequently, replace the control board.
ACLO	AC voltage to the controller is low for more than 30 seconds.	Check for low voltage at the wall outlet at unit start-up.	Contact a qualified electrician.



Error	DESCRIPTION OF ERROR CODE	CHECKING METHOD	Corrective Action
SF	Scaling Factor error - one of the credit peripherals has introduced a scaling factor that is not compatible with the current configuration.	Check the connections of changer harness; make sure changer is plugged in and working.	Make corrections to harness or replace the changer if necessary.
IS	Machine's coin inlet sensor is blocked for more than 1 minute.	Check changer harnessing for cut, pinched or crimped wires.	Replace harnesses or changer.
lb	3 successive coins are detected at the inlet but do not make it into the changer in 10 seconds.	Check inlet for blockage. If nothing is found, check changer harnessing for cut, pinched or crimped wires.	Clear blockage or replace harness or changer.
ERROR	PROBABLE CAUSE	CORRECTIVE ACTION	
Coin Acceptance/Payout (Record all errors for reference if Vendo Technical Service is required)			
Coin mechanism will not accept coins.	No power to control board.	Check to make sure the red LED on the control board is flashing red. If flashing, check MDB harness connections. If connections are good, replace changer.	
	Harness from coin mech to board is cut or disconnected.	Use a meter and check each wire for continuity and ground.	
	Short in coin mechanism.	Replace coin changer/acceptor.	
	Acceptor is dirty or other problem may exist (not tuned).	Clean acceptor or contact your local coin mech dealer.	
	Defective control board.	Replace control board.	
No acceptance or rejects a percentage of good coins.	Coin return lever pressing down on acceptor's coin plunger.	Make sure changer is mounted correctly and the coin return lever is in the proper position.	
	Acceptor is dirty or foreign matter is in the path.	Clean acceptor or contact dealer.	
	Coin changer is improperly tuned (if tunable).	Contact manufacturer for tuning.	
	Defective control board.	Replace/test control board.	
Always accepts coins but gives erratic/no credit.	If NO CREDIT: Defective harness between coin mech and control board (will have "CC" error).	Check harness for cut wires or wrong/bad connections. Test each wire for continuity or test to ground. If found to be defective, replace.	
	If ERRATIC OR NO CREDIT: Acceptor or coin mech.	Replace coin mech and test.	
	If NO CREDIT: Defective control board.	Replace/test control board.	
Changer will not payout coins.	Defective harness between coin mech and control board.	Test vendor's manual coin payout. If vendor won't pay out using the COIN mode or during sales, check harness for cuts, bad continuity or wrong connections. If defective, replace and test.	
	Defective coin mech.	Replace coin mech and test.	
	Defective controller board.	If coin mech won't payout coins manually in the COIN mode or during the Sales Mode and the above two procedures have failed, replace the control board and test payout both in the COIN mode and during a sale.	
	Changer payout buttons are disabled while door is closed or while in Open-Door Sales Mode.	Enter the Service Mode or access the Coin Payout Mode ("COIN").	
BILL ACCEPTANCE			
Bill validator will not pull bill in.	No power to validator.	Turn off power switch. Wait for 10 seconds. Turn on power switch and see if bill validator cycles. If not, check validator harnessing or replace the bill validator.	
	Acceptance disabled by coin mech (if present), or bad harnessing.	Make sure that the coin mech is plugged in (accepts coins) and that the coin tubes have enough coins to enable bill acceptance.	
	Coin mech is not operative.	Make sure that the changer harnessing is correctly connected and has continuity. Repair or replace if necessary.	
	Replace validator and test.	If validator accepts, bill validator was defective.	



ERROR	PROBABLE CAUSE	CORRECTIVE ACTION
Bill validator takes a bill but does not establish credit.	Defective validator harness (credit not getting from validator to control board through the harness).	Make sure that the validator and harnessing is correct for your style of validator and it is plugged in and wired properly.
	Defective validator.	Replace/test validator.
	Defective control board.	Replace/test control board.
Bill validator takes a bill and credits but not erasing credit.	Defective bill validator.	Replace validator and test acceptance and erasure of credit.
	Defective control board.	Replace/test control board for erasure of credit.
	Both vend sensors are defective.	Replace vend sensor.
Validator takes a bill and allows payback of coins without a selection.	Configurations not set properly in control board.	Access vendor configuration mode and check the "Force Vend" setting.
VENDING PROBLEMS		
Multiple vending (not canceling credit).	If multiple vending is from all selections, delivery sensor is cut, improperly grounded, or defective.	Replace sensors and test.
	NOTE: If both sensors are not present or are defective, the V21 will allow up to four products from each column to be vended before the column is determined to be sold out.	Replace sensors and test.
	Depth setting on partition not adjusted correctly.	Move can clip to proper position (refer to loading diagram on machine).
	Mechanical Error.	Check for correct operation of the motor, gate link, bucket and gate.
Wrong product vending upon selection.	Misload by vendor loader.	Ensure that all product within each column is the same.
	Space-to sales not set properly.	Look for StS error. Check or reset space-to-sales.
	Miswired selection.	Check the wiring from the controller to the selection switches. Test selection switches.
No vend upon selection.	Delivery sensor is malfunctioning or a column is jammed or sold out.	Check to see if the delivery chute sensor LED is constantly on. If so, replace vend sensor.
	Defective controller board.	Unplug the sensors connection from the control board. Watch LED. If the sensor LED stays on, replace the defective control board.
Dry Vend (No refund).	Premature vend detection.	Tap on chute and check for a green flashing light on the control board. If no light is flashing or light is constantly on, replace sensors.
Completely sold out.	Check to see if blocking is enabled.	Change time or turn off blocking.
	Check if vend sensor is unplugged.	Plug back in.
	Space to sales has been cleared.	Reinitiate space to sales.
MISCELLANEOUS PROBLEMS		
Display shows sold out immediately upon pressing selection button of full column (sold out not clearing).	Door switch wired incorrectly or cut/pinched.	Manually press door switch. If lights and fan don't come on, check wiring or replace door switch.
	Control board.	If door switch is replaced and still reading sold out, replace control board.
Vendor appears dead; no digital display and no lights.	Defective main harness or secondary power harness to the transformer.	Check transformer.



ERROR	PROBABLE CAUSE	CORRECTIVE ACTION
No digital display; vendor lights on.	Defective display or display harness.	Check display and display harness. Replace if necessary.
	Check for a flashing red light on control board.	If no light, replace control board.
Vendor scrolls message on display but does not accept money.	Changer out of tune.	See "Tuning Changer".
	Defective changer.	Replace changer.
	Defective control board.	Replace control board.
Vendor accepts money but does not credit.	Defective changer.	Replace changer.
	Defective control board.	Replace control board.
Vendor accepts and credits money but does not vend (does not indicate a sold-out).	Defective selection switch	Replace switch
	Defective selection switch harness	Repair or replace harness.
	Defective control board.	Replace control board.
Vendor delivers wrong product.	Vendor loaded wrong.	Correct loading.
	Vendor space-to-sales set wrong.	See "StS".
	Defective control board.	Replace control board.
Flashing 8888's on the LED.	Chips on control board not seated properly.	Seat the chips down properly
	Bad LED connection.	Replace LED and/or harness.
	Defective control board.	Unplug everything from the board except the LED and power in. If the 8888's remain then replace the control board.
	Defective components.	If the 8888's have disappeared from the previous step, then begin plugging in harnesses one at a time. Replace whatever causes the 8888's to reappear. Be sure to power down each time you plug in a harness.
Solid 8888's on the LED.	Defective LED.	Replace LED and/or harness.
	Defective control board.	Replace control board.
Refrigeration		
Refrigeration unit will not run even at the specific temperature	No power or insufficient to refrigeration unit	Check power supply and connection to see if each component gets the specific voltage of power. Replace parts and line if necessary.
	Defective temperature sensor	Replace temperature sensor
	Defective relay	Replace the refrigeration relay
	Defective control board	Replace board
Unit will only run in the compressor test mode. (Located under tEST)	Defective door switch.	Open and close the door to make sure lights and fan come on. If not, then check the door switch.
	Defective temperature sensor	Follow the same steps detailed above about the temperature sensor.
	Wait the 3 minute delay once the door is closed	Wait to see if unit comes on.
	Defective control board	If unit still does not come on, then replace the control board
Unit will not run even in the compressor test mode. **NOTE: Leave the compressor test mode on in order to check for voltage.	Defective door switch.	Upon opening the door, the lights and condenser fan motors should shut off. If they don't replace the door switch.
	Defective control board	Replace the board.
Refrigeration unit runs constantly.	Defective door switch.	Upon opening the door, the lights and compressor should shut off. If they don't replace the door switch.
	Defective control board	Replace the board.
	Defective relay	Replace the refrigeration relay
Condenser fan motor doesn't run.	Defective condenser fan motor	Replace the motor
	Bad connection	Check the connection and lines
	Defective relay	Replace the condenser motor relay



ERROR	PROBABLE CAUSE	CORRECTIVE ACTION
Compressor will not start, condenser fan motor running - unit hot (power to compressor)	Defective overload relay	Replace the overload relay.
	Compressor motor rocked	Replace the refer unit.
	Defective capacitor	Replace the capacitor.
	Defective PTC relay	Replace the PTC relay.
Compressor starts but doesn't run.	Loss of refrigerant	Replace the refrigeration unit.
	Smashed tubings and capillary	Replace the refrigeration unit.
	Defective overload relay	Replace the overload relay.
Compressor runs but cabinet temperature warm.	Loss of refrigerant	Replace the refrigeration unit.
	Smashed tubings	Replace the refrigeration unit.
	Defective drainage	Make sure the drain hose is not kinked or clogged.
	Defective temperature sensor	Replace the temperature sensor.
	Poor air flow	Make sure nothing is sitting in front of the evaporator.
	Defective control board	Replace the control board.
	Defective door seal	Make sure the vend flap and gasket are not open or damaged.
	Defective heat exchange on condenser/ Blocking air flow by dust, lint or fin damage	Clean the surface of the condenser fins or straighten the bent fins.
Evaporator frosted over	Loss of refrigerant	Replace the refrigeration unit.
	Smashed tubings	Replace the refer unit.
	Defective drainage	Make sure the drain hose is not kinked or clogged. Re-install hose correctly if kinked or clogged.
	Defective temperature sensor	Replace the temperature sensor.
	Defective control board	Replace the board.
	Poor sealing	Check gasket, vend flap, and permagum on the bulkhead.
Product freezing up (too cold)	Temperature setting too low.	Adjust set point in control board.
	Defective temperature sensor	Replace the temperature sensor.
	Defective control board	Replace the board.
Excessive noise	Fan blade hitting shroud or loose fitting	Replace the fan blade or re-install correctly.
	Defective fan motor	Re-install or replace the motor.
	Defective compressor	Replace the refrigeration unit.
	Refrigeration base deformed	Re-install or replace the base and plastic trim.
Drain pan over flow	Poor sealing	Make sure the vend flap closes correctly and the gasket is sealing.
	Evaporation board (wick) dirty	Clean or exchange the evaporation board.
	Drain hose falls out from the stud of drain pan.	Install hose correctly .
	Defective condenser fan motor	Replace the motor.
	Abnormal amount of water goes into the pan at one time	Throw out the water and check periodically to make sure the problem is not still occurring.
Heater		
Heater will not run even at the specific ambient temperature	No power to refrigeration unit	Check power supply and connection. Replace if necessary.
	Defective temperature sensor	Replace temperature sensor.
	Defective relay	Replace the heater relay.
	Defective control board	Replace the control board
Refrigeration unit will not run even at the specific cabinet temperature	No power to refrigeration unit	Check power supply and connection. Replace if necessary.
	Defective temperature sensor	Replace temperature sensor.
	Defective control board	Replace the control board
Unit will only run in the heater test mode. (Located under tEST)	Defective door switch.	Open and close the door to make sure lights and fan come on. If not, then check the door switch.
	Defective temperature sensor	Follow the same steps detailed above about the temperature sensor.
	Defective control board	Replace the control board.



ERROR	PROBABLE CAUSE	CORRECTIVE ACTION
Unit will not run even in the heater test mode. **NOTE: Leave the compressor test mode on in order to check for voltage.	Defective door switch.	Upon opening the door, the lights and compressor should shut off. If they don't replace the door switch.
	Defective control board	Replace the board.
Heater runs but product freezing up.	Defective heater	Replace the heater assembly.
	Poor air flow	Make sure that nothing is sitting in front of the heater.
	Defective evap fan motor	Check the connection and installation of fan blade. Replace the motor if necessary.
	Defective temperature sensor	Replace the temperature sensor.
	Defective control board	Replace the board.
	Defective door seal	Make sure the vend flap and gasket are not open or damaged.



NOTES