

VOCE
MEDIA



U.S. Parts Manual

Part Number: PR15326000

revB - MARCH 2017

Safety First! Take care, risk of personal injury when installing or removing parts.

Crane Merchandising Systems accepts no responsibility for damage caused to the equipment through misinterpretation or misuse of the information contained in this manual.

© Copyright 2012 Crane Merchandising Systems

Introduction

This manual provides you with a visual guide of the parts located within the machine which will help you with the installation, removal and basic maintenance of your VOCE Media freestanding vending machine. Crane Merchandising Systems always recommend that a trained technician service its equipment.

Crane Merchandising Systems is committed to continuous product improvement. This means that the information within this document, although correct at time of publication, is for guidance only and may be subject to change without prior notice.

This machine has been engineered to our own rigid safety and performance requirements and manufactured in accordance with the safety standards of Underwriters Laboratories (UL) and the Canadian Standards Association (CSA).

It has been designed to comply with the National Automatic Merchandising Association (NAMA) "Standard for the Sanitary Design and Construction of Food and Beverage Vending Machines".

To maintain this degree of safety and to continue to achieve the level of performance built into this machine, it is important that the installation and maintenance be performed so as to not alter the original construction or wiring and that replacement parts are as specified in this **Parts Manual**.

Your investment in this equipment will be protected by using the **Technical Manual** and this **Parts Manual** in your operation, service and maintenance work. By following the prescribed procedures, machine performance and safety will be preserved.

CRANE MERCHANDISING SYSTEMS PARTS & TECHNICAL SUPPORT

PARTS:

Tel: 1-800-621-7278

Email: parts@cranems.com

SERVICE: 1-800-628-8363

Email: service@cranems.com

For faster service, please have your account number ready before calling.

www.cranems.com

TERMS AND CONDITIONS OF SALE

1. PRICES: All prices, quotations, shipments and deliveries by Seller are F.O.B Seller's plant. All base prices are subject to change without notice and all orders are accepted subject to Seller's price in effect at the time of shipment.

2. APPLICABILITY, ACCEPTANCE AND MODIFICATION: These terms and conditions apply to all quotations and purchase orders covering the sale of Seller's products or services. Seller's acceptance of Buyer's order is expressly made conditional on Buyer's acceptance of the terms and conditions set forth herein. The terms and conditions set forth herein, together with the terms of all sale contracts, financing agreements, guaranties or security agreements between Buyer and Seller, constitute the complete agreement between the Seller and Buyer, and Seller's acceptance of any order from Buyer is accepted only in accordance with such terms. They may not be modified except by written agreement referring specifically to these terms and conditions and signed by a duly authorized officer or representative of Seller. Any provisions of Buyer's purchase order which are inconsistent with the foregoing shall be of no force and effect, unless Seller shall have agreed to a modification of these terms and conditions in the manner set forth herein. Buyer's failure to specify dissent to these terms and conditions, or its acceptance or use of products or services of Seller shall constitute Buyer's acceptance of these terms and conditions. Buyer, by these presents and the acceptance of the goods ordered herein represents and warrants that buyer is solvent and able to pay for the goods in accordance with these terms and conditions of sale.

3. DELIVERY AND DELAYS: Seller's obligation is to deliver the goods F.O.B Seller's place of manufacture. Risk of loss passes to Buyer at the moment of delivery. Delivery dates given to Buyer in any manner, are approximate. Seller shall not be liable for any delay in delivery or for non-delivery, in whole or in part, caused by the occurrence of any contingency beyond the control of the Seller or suppliers to the Seller, including, but not limited to war, (whether an actual declaration thereof is made or not), sabotage, insurrection rebellion, riot or other act of civil disobedience, act of public enemy, failure or delay in transportation, act of any government or any agency or subdivision thereof, judicial action, labor dispute, fire accident, explosion, epidemic, quarantine, restrictions, storm, flood, earthquake or other act of God, shortage of labor, fuel, raw materials, machinery or technical failure, if any such contingency occurs. Seller may allocate production and deliveries among Seller's customers in its sole discretion.

4. STORAGE: In the event that Buyer is unable to accept delivery of parts or equipment at the time of completion and/or shipment, Seller may invoice for the full purchase price as if shipment has been made and; or (i) if Seller is able to store such equipment in its own facilities the Buyer shall pay Seller reasonable handling and storage charges for the period of such storage; or (ii) if seller is unable to store such equipment in its own facilities, Seller reserves the right to arrange handling and storage in a suitable warehouse for the buyer, at the Buyer's expense. In case where handling and storage becomes necessary, it will become the responsibility of the Buyer to notify Seller when shipment is to be made and destination.

TERMS AND CONDITIONS OF SALE

5. LIMITED WARRANTY: Subject to the limitations specified herein, all parts included on original equipment manufactured by CRANE MERCHANDISING SYSTEMS and sold to purchaser are warranted for two years from the date of shipment of the equipment in question. This warranty applies only to the original purchaser of the Merchandiser and is null and void if the Merchandiser is sold during the period of warranty.

Defective parts will be repaired or replaced free of charge when the defective part is returned, with transportation charges prepaid by Purchaser to a destination designated by CRANE MERCHANDISING SYSTEMS.

This warranty does not include any cost of service rendered or repairs made by customer or its agents on Merchandise, or parts, unless authorization to incur such expense has been given in writing by CRANE MERCHANDISING SYSTEMS prior to incurring such expense. This warranty covers labor and service charges performed by CRANE MERCHANDISING SYSTEMS service technicians for a period of 90 days from the date of shipment.

This warranty does not apply to A) electrical components, wiring, or circuits or mechanical parts or assemblies damaged as a result of operating the Merchandiser at other than the design voltage and frequency specified on the Electrical Rating tag, or B) in event of vandalism, fire or negligence, or C) incandescent lamps, neon lamps, fluorescent lamps, ballasts, starters or other expendable items damaged as a result of vandalism, fire or negligence, or C) incandescent lamps, neon lamps, fluorescent lamps, ballasts, starters or other expendable items or D) when seal is broken on electronic boards or E) when other manufactured components are installed in CRANE MERCHANDISING SYSTEMS Merchandisers.

Replacement parts sold by CRANE MERCHANDISING SYSTEMS as After Market shall be covered for three months from the date shown on the parts invoice.

Purchaser must obtain prior RETURN AUTHORIZATION for return of all parts, following guidelines given by CRANE MERCHANDISING SYSTEMS.

New, unused parts purchased as After Market can be returned within 30 days from the date of parts invoice, with prior authorization from CRANE MERCHANDISING SYSTEMS and subject to a re-stocking fee.

THIS WARRANTY IS IN LIEU OF ALL OTHER WARRANTIES EXPRESS OR IMPLIED, INCLUDING WITHOUT LIMITATION, WARRANTIES OF MERCHANTABILITY OF FITNESS FOR A PARTICULAR PURPOSE. CRANE MERCHANDISING SYSTEMS WILL NOT BE RESPONSIBLE FOR CONSEQUENTIAL OR PUNITIVE DAMAGES. CRANE MERCHANDISING SYSTEMS neither assumes nor authorizes any person to assume for it any obligation or liability in connection with the sale of said equipment or any part thereof.

6. LIMITATIONS OF BUYER'S REMEDIES: Buyer's remedies with respect to any claim arising out of any Crane Merchandising Systems' equipment, parts or services, or Crane Merchandising Systems' performance in connection therewith shall be limited exclusively to the warranty specified in Paragraph 5, which warranty shall be limited to the cost of the part or equipment in question.

TERMS AND CONDITIONS OF SALE

7. WAIVER: Waiver by Seller of any breach by Buyer of any of the terms and conditions set forth herein shall not be construed as a waiver of any other breach, and the failure of Seller to exercise any right arising from any default of Buyer hereunder shall not be deemed to be a waiver of such right, which may be exercised at any subsequent time.

8. ADEQUATE ASSURANCES: Seller may, at any time, suspend performance of any order or require payment from Buyer in cash, security or other adequate assurance satisfactory to Seller when, in Seller's sole opinion, the financial condition of Buyer or other grounds for insecurity warrant such action.

9. TAXES: Any tax which the Seller may be required to pay or collect, through assessment or otherwise, under any existing or future law upon or with respect to the sale, purchase, delivery, transportation, storage, processing use or consumption of any goods or services provided by Seller to Buyer, including taxes upon or measured by receipts from sales or services, shall be for the account of Buyer and may be added to the price of goods or services purchased by Buyer. Buyer shall promptly pay the amount thereof to Seller upon demand.

10. GOVERNING LAW: This agreement shall be governed by and construed in accordance with the laws of the State of Missouri. Buyer consents to the jurisdiction of the state and federal courts within the State of Missouri.

11. CREDIT. All orders are subject to the approval of Seller, and Seller may at any time refuse to ship or deliver goods to Buyer. All invoices paid after the due date specified within shall accrue interest at the lesser of 2% per month or the highest rate of interest permitted by law.

12. ALL SALES ARE FINAL. This is not a "Sale on Approval" or "Sale on Return" transaction. All sales are final.

TABLE OF CONTENTS

DOOR GLASS - FULLY INTEGRATED	1
DOOR GLASS - SINGLE KNOCKOUT	2
DOOR GLASS - DOUBLE KNOCKOUT	3
EXTERIOR VIEW OF DOOR (TABLE)	4
BACKSIDE VIEW OF DOOR	5
BACKSIDE VIEW OF DOOR (TABLE)	6
INTERIOR CABINET VIEW	7
INTERIOR CABINET VIEW (TABLE)	8
605 FRESHBREW CANISTER CONFIG. & (TABLE)	9
605 FRESHBREW CANISTER ASSEMBLIES & (TABLE)	10
606 SOLUBLE CANISTER CONFIG. w/DECAF (TABLE)	11
606 SOLUBLE CANISTER ASSY'S w/DECAF (TABLE)	12
606 SOLUBLE CANISTER CONFIG. w/o DECAF (TABLE)	13
606 SOLUBLE CANISTER ASSY'S w/o DECAF (TABLE)	14
607 B2C CANISTER CONFIG. (TABLE)	15
607 B2C CANISTER ASSEMBLIES (TABLE)	16
607 SBC CANISTER CONFIG. (TABLE)	17
607 SBC CANISTER ASSY'S (TABLE)	18
607 B2C GRINDER ASSY.	19
607 B2C GRINDER ASSEMBLY (TABLE)	20
SUREVEND EMITTER SENSOR LH (TABLE)	21
SUREVEND EMITTER SENSOR RH (TABLE)	22
ELECTRONICS PANEL (TABLE)	23
FUSE & RELAY PANEL (TABLE)	24
DISPENSE HEAD ASSEMBLY	25
DISPENSE HEAD ASSEMBLY (TABLE)	26
TURRET & CUP DROP UNIT ASSEMBLY	27
TURRET & CUP DROP UNIT ASSEMBLY (TABLE)	28
CMS WHIPPER MIXING SYSTEM	29
CMS WHIPPER MIXING SYSTEM (TABLE)	30
NESTLÉ WHIPPER MIXING SYSTEM (TABLE)	31
WATER TANK ASSEMBLY.....	32
WATER TANK ASSEMBLY (TABLE)	33

TABLE OF CONTENTS

OLTRE BREWER - FRESHBREW, USA	34
OLTRE BREWER - FRESHBREW, USA (TABLE)	35
EXHAUST FAN ASSEMBLY & (TABLE)	36
LIQUID & GROUNDS BUCKETS / FLOOR LINER & (TABLE) ..	37
MISCELLANEOUS PARTS (1 THRU 10)	38
MISCELLANEOUS PARTS (11 THRU 20)	39
MISCELLANEOUS PARTS (21 THRU 30)	40
MISCELLANEOUS PARTS (31 THRU 40)	41
MISCELLANEOUS PARTS (41 THRU 50)	42
MISCELLANEOUS PARTS (51 THRU 60)	43
MISCELLANEOUS PARTS (61 THRU 70)	44
MISCELLANEOUS PARTS (71 THRU 80)	45
MISCELLANEOUS PARTS (81 THRU 90)	46
MISCELLANEOUS PARTS (91 THRU 100)	47
MISCELLANEOUS PARTS (101 THRU 110)	48
MISCELLANEOUS PARTS (111 THRU 120)	49
MISC. NUTS, SCREWS & WASHERS	50
MISC. NUTS, SCREWS & WASHERS	51
PART NUMBER INDEX	52
PART NUMBER INDEX	53
PART NUMBER INDEX	54
PART NUMBER INDEX	55
PART NUMBER INDEX	56
PART NUMBER INDEX	57
PART NUMBER INDEX	58
PART NUMBER INDEX	59
PART NUMBER INDEX	60
PART NUMBER INDEX	61
PART NUMBER INDEX	62
PART NUMBER INDEX	63
NOTES PAGES	64, 65, 66
REAR COVER PAGE (contains Contact Information.....)	67

EXTERIOR DOOR VIEW '2a' (Fully Integrated)

EXTERIOR DOOR VIEW '2b' (Single Knockout)



A FRESH APPROACH TO VENDING

EXTERIOR DOOR VIEW '2c' (Double Knockout)

EXTERIOR VIEW OF DOOR

REF #	PART #	DESCRIPTION
1	MT13807000	SURROUND, PAINTED - VOCE SP
2	*****	3 GLASS DOOR OPTIONS (see options 2a, 2b, 2c)
2a	GR14979000	GLASS PRINT, VM CARD SW BLUE SWIRL (Fully Integrated)
2b	GR14978000	GLASS PRINT, VM STANDARD US BLUE SWIRL (Single Knockout)
2c	GR14981000	GLASS PRINT, 3 PAYMENT BLUE SWIRL (Double Knockout)
3	*****	BILL VALIDATOR (Customer preference)
4	CR0012773	INSERT, COIN RAMP - MERCHANT/BEVMAX-G
5	CR0014768	ASSY, CARD READER, AND MAGHEAD, G
6	*****	COIN RETURN CUP
7	CR0024840	PLATE, KICK
8	ME13244000	FOOT RIGID M12
9	*****	CUP VEND AREA ASSY.
10	ME13150000	ASSY. SPRING LOCK, LOW PROFILE
11	EL14295000	SCREEN 8.4" LCD
**a	CR0026201	STANDARD KNOCKOUT, POLYCARB/PSG
**b	CR0026208	2 KNOCKOUT, POLYCARB/PSG
**c	CR0025225	FULLY INTEGRATED, POLYCARB/PSG
**d	CR0027431	STANDARD KNOCKOUT W/NO COIN, POLYCARB/PSG
**e	CR0028398	INTEGRATED W/STANDARD KNOCKOUT POLYCARB/PSG

NOTE: Reference numbers ****a thru **e** are baseline Polycarbonate Doors without any Customized graphics. Please contact your local CMS Representative or our CMS Sales and/or Parts Representatives for available graphic options or to have your own customized graphic.

BACKSIDE VIEW OF DOOR

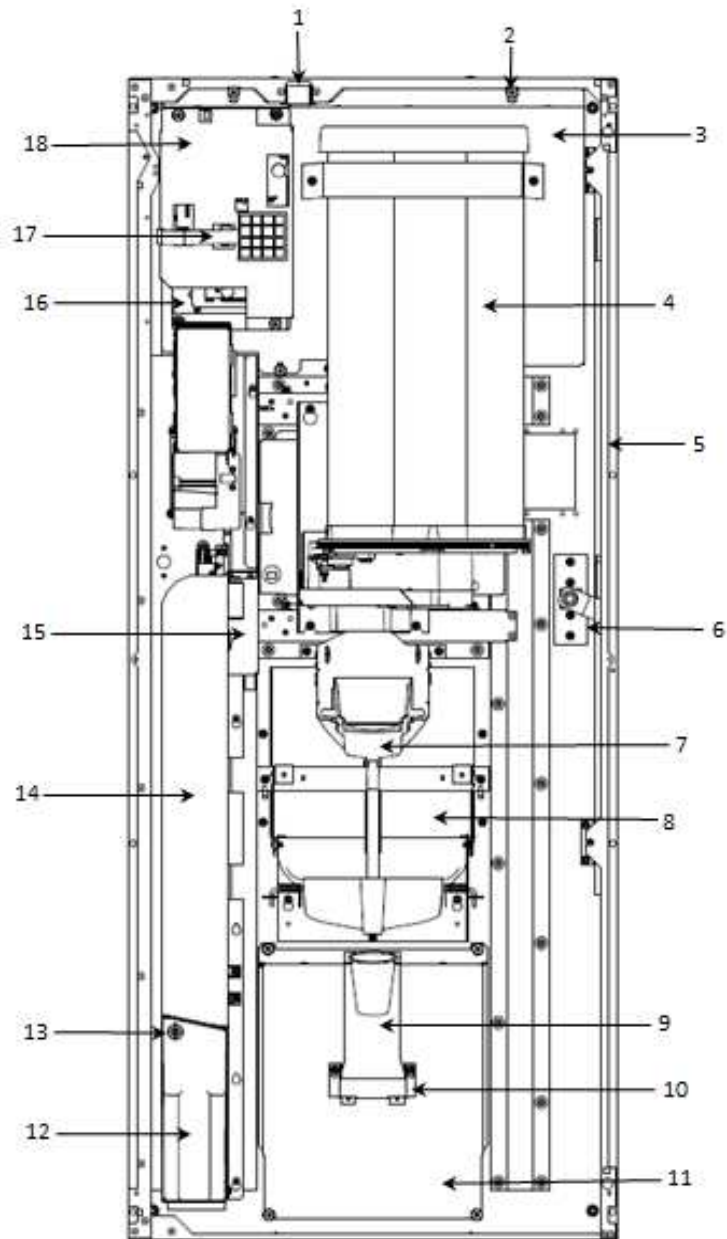

BACKSIDE VIEW OF DOOR

REF #	PART #	DESCRIPTION
1	MT14176000	BRACKET, DOOR SWITCH ACTUATOR - VOCE SP
2	FA07905000	BUTTON, FIR TREE, BLACK VOCE SP
3	EL13908000	ASSY, LED STRIP UPPER - VOCE SP
4	*****	CDU TUBES (3 styles used, see 4A, 4b, 4c)
4a	PL13840002	TUBE, TURRET 7oz./9oz. - VOCE SP
4b	PL13842002	TUBE, TURRET 12oz. - VOCE SP
4c	PL13873000	TUBE, 16oz./20oz. TURRET - VOCE SP
5	MT13805000	LOCK BAR - VOCE SP
6	ME13150000	ASSY., SPRING LOCK, LOW PROFILE - VOCE SP
7	*****	CUP CATCHER (3 styles used, see 7a, 7b, 7c)
7a	PL13126000	CUP CATCHER, 73mm - VOCE SP
7b	PL13128000	CUP CATCHER 80mm - VOCE SP
7c	CR0023344	CUP CATCHER, 90mm - VOCE SP
8	*****	CUP DELIVERY AREA (see pages 38, 43 & 102)
9	CR0028201	BRACKET, DRIP CATCHER - VOCE
10	MT14065290	BRACKET, PIVOT DRIP CATCHER - VOCE
11	EL13909000	STRIP, LED LOWER - VOCE SP
12	1671090	COIN BOX
13	ME01859000	CASH BOX LOCK - VOCE SP
14	MT13085290	PANEL, MONETARY - VOCE SP
15	CR0014114	ASSY, PCB, LED DRIVER - GLOBAL
16	MT15089	ATLAS 'G', MOUNTING PLATE
17	EL10025002	PROGRAMMING KEYPAD, VOCE
18	CR0026399	COVER, ATLAS BOARD

INTERIOR CABINET VIEW

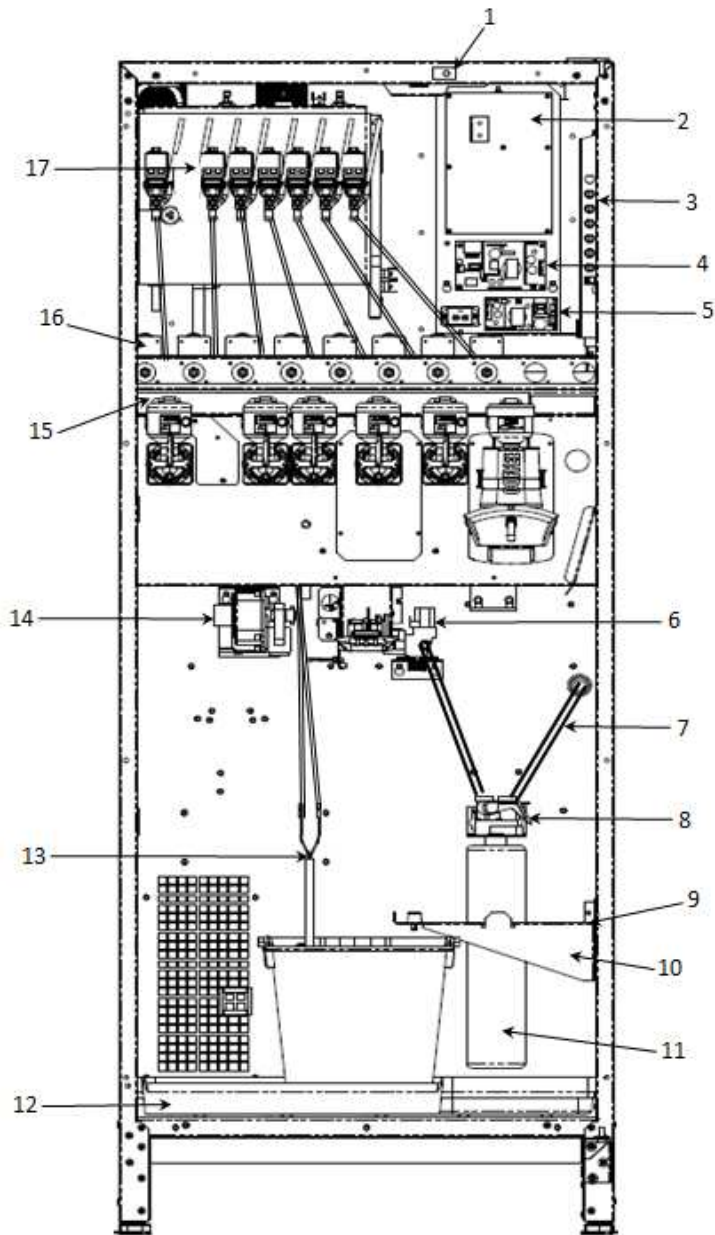

INTERIOR CABINET VIEW

REF #	PART #	DESCRIPTION
1	1236050	SWITCH, DOOR
2	EL13059001	I/O (INTERFACE PCB)
3	MT13078000	PSU BRACKET
4	EL14585000	POWER SUPPLY, SMPSU, 24VDC
5	EL13165000	SMPSU 12 VDC POWER SUPPLY
6	613VA11700000	VALVE INLET 24V DC DOUBLE
7	HO11253000	HOSE, EVERPURE 3/4" BSP-3
8	6408134	FILTER HEAD, EVERPURE
9	613MT13039000	BUCKET SUPPORT, SIDE RAIL
10	CR0024823	BUCKET STAND, VOCE
11a	6118071	CARTRIDGE WATER FILTER - 4H
11b	6738047	HYDROLIFE, HLV192AD - ADAPTOR KIT
12	CR0027483	LINER, FLOOR, VOCE
13	PA13590000	ASSY., WASTE LEVEL PROBE
14	613ME10956000	EXHAUST FAN - 120VAC - USA
15	613MT13914340	MODULE, EXTRACT TRAY, (TFB)
16	MO10152001	INGREDIENT MOTOR 24VDC - 125 RPM
*17	6050002	KIT VALVE & SEAL (MULLER) - 24VDC
17a	VA10148002	VALVE DISPENSE 24V DC - (MÜLLER)
17b	VA03377002	SEAL, PORT, VALVE - (MÜLLER)
17c	VA01838A00	VALVE, DISPENSE, REPAIR KIT (MÜLLER)

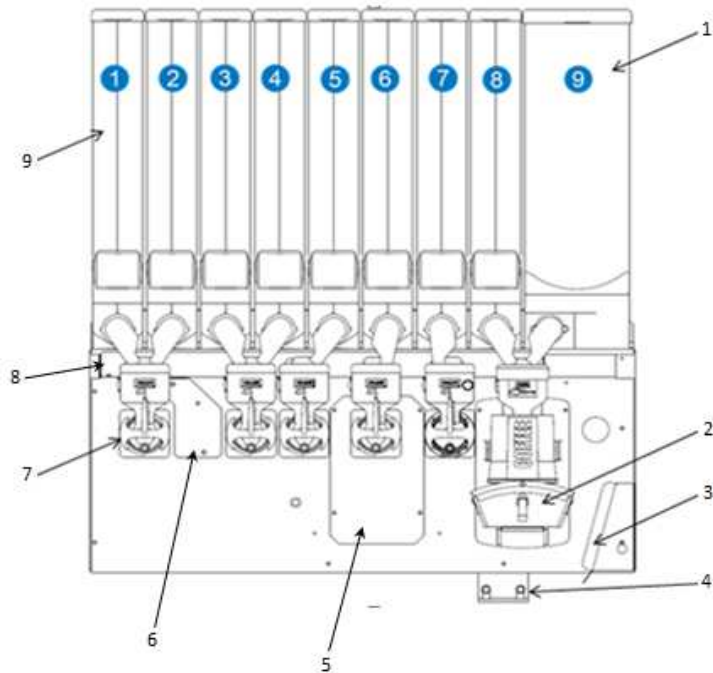
(605) FRESH BREW CANISTER CONFIG.

REF #	PART #	DESCRIPTION
1	PL14515000	CAN S x 137 x 460 & AGITATOR & SS FB
2	613ME13414000	BREWER ASSY., OLTRE 83MM - COMPLETE (see page 34 & 35)
3	613MT14400000	WASTE CHUTE, OLTRE BREWER, RH
4	ME13592001	PERISTALTIC PUMP ASSY.
***	PA13650000	TUBING, PERISTALTIC PUMP (see page 44)
5	MT14465000	BLANKING PLATE, WHIPPER (LARGE)
6	MT13766000	BLANKING PLATE, WHIPPER (SMALL)
7	*****	CMS MIXING SYSTEM
8	613MT13914340	MODULE, EXTRACT TRAY (TFB)
9	*****	CANISTER ASSY., #'s 1 thru 8 (see page 10)

(605) FRESH BREW CANISTER ASSY'S

PL11608	PL11170	PL11170	PL11170	PL11170	PL11170	PL11608	PL11172	PL14515
SUGAR	WHITENER	CAPPUCCINO TOPPING	CHOCOLATE	SOLUBLE PRODUCT (1)	SOLUBLE PRODUCT (2)	DECAF COFFEE	GROUND COFFEE (1)	GROUND COFFEE (2)

REF #	PART #	DESCRIPTION
1	PL11608000	CANISTER, 67W (NO AGITATOR) X 460H (Used for SUGAR & FREEZE DRIED DECAF COFFEE)
2	PL11170000	CANISTER 67W x 460H with AGITATOR (Used for WHITENER, CAPPUCCINO TOPPING, CHOCOLATE, and SOLUBLE #1 & #2)
3	PL11172000	CANISTER, 67MM-C/W AGITATOR & SS (Used for FRESH BREW GROUND COFFEE #1)
4	PL14515000	CANISTER S x 137 x 460 & AGITATOR & SS FRESH BREW (Used for FRESH BREW COFFEE #2)

(606) SOLUBLE CANISTER CONFIG. DECAF OPTION w/2 SOLUBLES

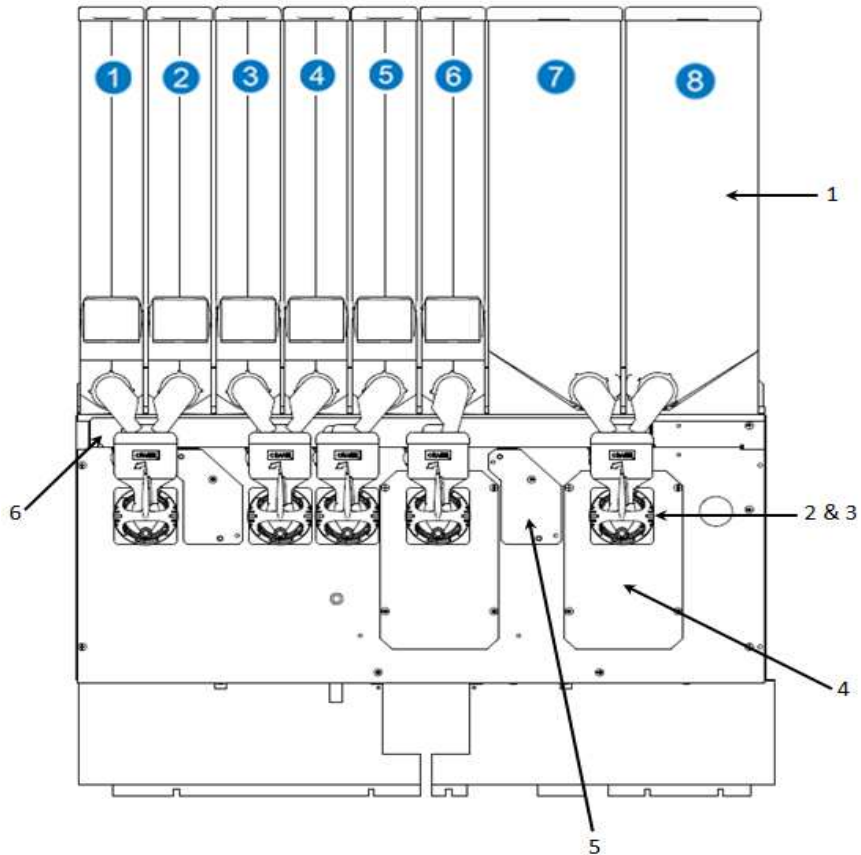

REF #	PART #	DESCRIPTION
1	*****	CANISTER ASSY., #'s 1 thru 8 (see page 12)
2	*****	CMS MIXING SYSTEM (see page 29 & 30)
3	*****	NESTLÉ MIXING SYSTEM (see page 31)
4	MT14465000	BLANKING PLATE, WHIPPER (LARGE)
5	MT13766000	BLANKING PLATE, WHIPPER (SMALL)
6	MT13755340	MODULE, EXTRACT TRAY, DECAF / 2 SOLUBLES

(606) SOLUBLE CANISTER ASSEMBLIES DECAF OPTION w/2 SOLUBLES

PL11608	PL11170	PL11608	PL11608	PL11170	PL11170	PL13717	PL10821
SUGAR	WHITENER	INSTANT COFFEE	INSTANT DECAF COFFEE	SOLUBLE PRODUCT (1)	SOLUBLE PRODUCT (2)	CAPPUCCINO TOPPING	CHOCOLATE

REF #	PART #	DESCRIPTION
1	PL11608000	CANISTER, 67W (NO AGITATOR) X 460H (Used for the SUGAR & FREEZE DRIED COFFEE & DECAF)
2	PL11170000	CANISTER 67W x 460H with AGITATOR (Used for the WHITENER and SOLUBLE #1 & #2)
3	PL13717000	CANISTER, RH, 137D x 460H (Used for the CAPPUCCINO TOPPING ONLY)
4	PL10821000	CANISTER, LH x 137 x 460H (Used for CHOCOLATE ONLY)

(606) SOLUBLE CANISTER CONFIG. 3 SOLUBLES OPTION w/o DECAF

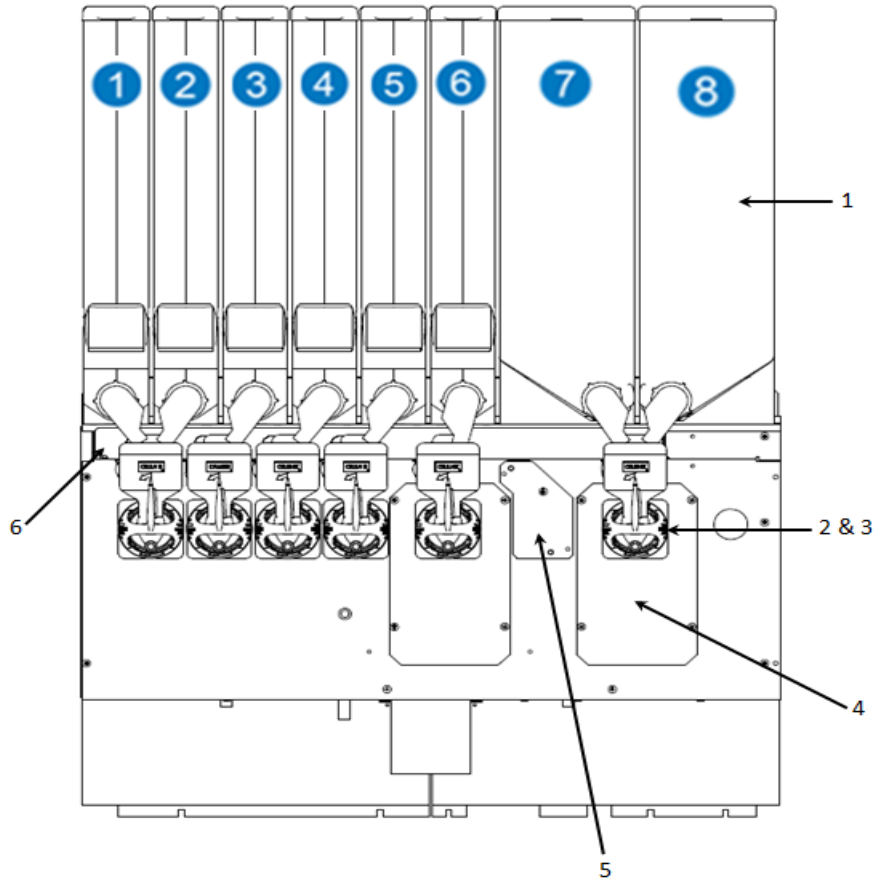

REF #	PART #	DESCRIPTION
1	*****	CANISTER ASSY., #'s 1 thru 8 (see page 14)
2	*****	CMS MIXING SYSTEM (see page 29 & 30)
3	*****	NESTLÉ MIXING SYSTEM (see page 31)
4	MT14465000	BLANKING PLATE, WHIPPER (LARGE)
5	MT13766000	BLANKING PLATE, WHIPPER (SMALL)
6	MT14710340	MODULE, EXTRACT TRAY, 3 SOLUBLES

(606) SOLUBLE CANISTER ASSEMBLIES 3 SOLUBLE OPTION w/o DECAF

PL11608	PL11170	PL11170	PL11170	PL11170	PL11170	PL13717	PL10821
SUGAR	WHITENER	INSTANT COFFEE	SOLUBLE PRODUCT (1)	SOLUBLE PRODUCT (2)	SOLUBLE PRODUCT (3)	CAPPUCCINO TOPPING	CHOCOLATE

REF #	PART #	DESCRIPTION
1	PL11608000	CANISTER, 67W (NO AGITATOR) X 460H (Used for the SUGAR & FREEZE DRIED COFFEE & DECAF)
2	PL11170000	CANISTER 67W x 460H with AGITATOR (Used for the WHITENER and SOLUBLE #1 & #2)
3	PL13717000	CANISTER, RH, 137D x 460H (Used for the CAPPUCCINO TOPPING ONLY)
4	PL10821000	CANISTER, LH x 137 x 460H (Used for CHOCOLATE ONLY)

(607) B2C CANISTER CONFIGURATION

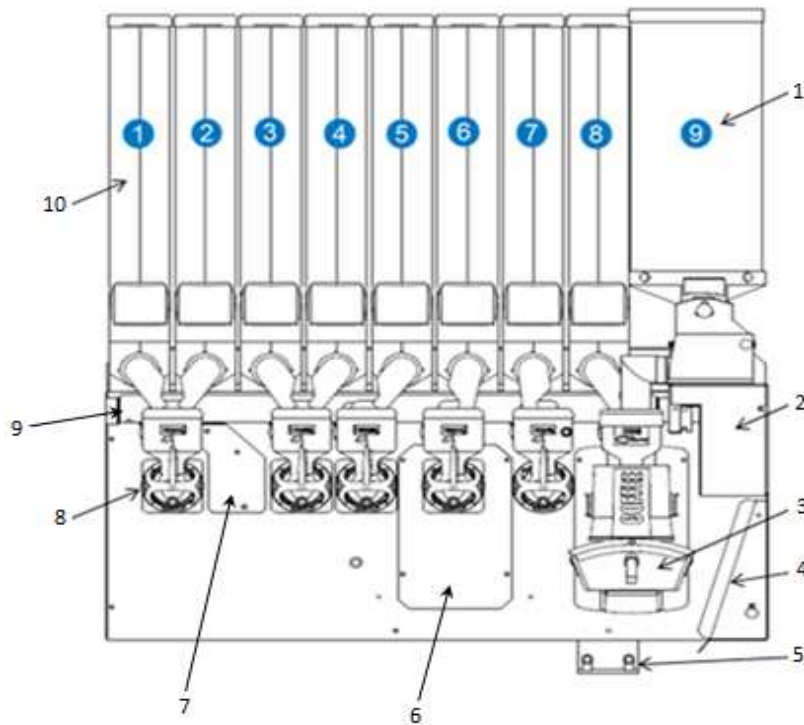

REF #	PART #	DESCRIPTION
1	PL14258000	HOPPER, BEAN, ROUND - 3lb.
2	MO10955000	GRINDER & MOTOR 120VAC - VOCE SP
3	613ME13414000	BREWER ASSY. , OLTRE 83MM, COMPLETE (see page 34 & 35 for details)
4	613MT14400000	WASTE CHUTE, OLTRE BREWER, RH
5	ME13592001	PERISTALTIC PUMP ASSY. - 24VDC
6	MT14465000	BLANKING PLATE, WHIPPER (LARGE)
7	MT13766000	BLANKING PLATE, WHIPPER (SMALL)
8	*****	CMS MIXING SYSTEM (see page 29 & 30)
9	613MT13914340	MODULE EXTRACT TRAY (TFB)
10	*****	CANISTER ASSY., #'s 1 thru 8 (see page 16)

(607) B2C CANISTER ASSEMBLIES

PL11608	PL11170	PL11170	PL11170	PL11170	PL11170	PL11608	PL11172	PL14258
SUGAR	WHITENER	CAPPUCCINO TOPPING	CHOCOLATE	SOLUBLE PRODUCT (1)	SOLUBLE PRODUCT (2)	DECAF COFFEE	GROUND COFFEE (1)	COFFEE BEANS
								GRINDER

REF #	PART #	DESCRIPTION
1	PL11608000	CANISTER, 67MM (NO AGITATOR), (Used for SUGAR & FREEZE DRIED COFFEE)
2	PL11170000	CANISTER 67W x 460H with AGITATOR (Used for the WHITENER, CAPPUCCINO TOPPING, CHOCOLATE, and SOLUBLES #1 & #2)
3	PL11172000	CANISTER, 67MM-C/W AGITATOR & SS (Used for FRESH BREW GROUND COFFEE)
4	PL14258000	HOPPER, BEAN, ROUND - VOCE SP (Used for FRESH BREW COFFEE BEANS)

(607*) SBC CANISTER CONFIGURATION

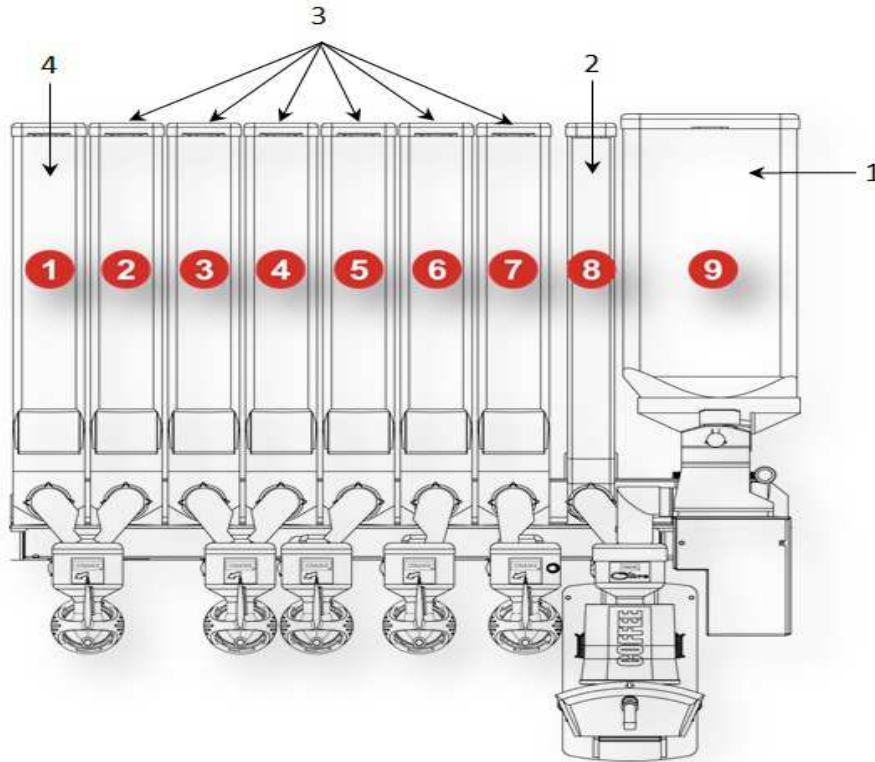

REF #	PART #	DESCRIPTION
1	CR0026531	CANISTER w/BRACKET, BEAN, LARGE - 8lb. (used for SBC Level 3 Bean Coffee)
2	PL10856000	CANISTER, 42 x 183 x 460H (used for SBC Level 4 Coffee)
3	PL11170000	CANISTER, 67W x 460H with AGITATOR (used for Whitener, Cappuccino Topping, Chocolate, French Vanilla, Caramel & Hazelnut)
4	PL11608000	CANISTER, 67W x 460H (used for Sugar)
*	*****	CANISTER ASSY., #'s 1 thru 9 (see page 18)
NOTE	*****	All other parts for the SBC configuration remain the same as the Standard 607 B2C. The only exceptions are the Canister Assemblies.

(607*) SBC CANISTER ASSEMBLIES

PL11608	PL11170	PL11170	PL11170	PL11170	PL11170	PL11170	PL10856	CR0026531
Sugar	Whitener	Frothy Topping Mix	Chocolate	French Vanilla Cappuccino	CaramelCappuccino	Hazelnut Cappuccino	SBC - Level 4	SBC - Level 3
								Grinder

NOTE: SBC Canisters are Product specific as set by our agreement with SEATTLE'S BEST

1. Sugar – 7.9 lbs. (3.6 kg)
2. Creamer – 5.8 lbs. (2.6 kg)
3. Cappuccino Topping – 4.8 lbs. (2.2 kg)
4. Chocolate – 6.5 lbs. (2.9 kg)
5. Flavor #1 gourmet soluble – 6.5 lbs. (2.9 kg)
6. Flavor #2 gourmet soluble – 6.5 lbs. (2.9 kg)
7. Flavor #3 gourmet soluble – 6.5 lbs. (2.9 kg)
8. FG or Decaf Coffee – 2.1 lbs. (1.0 kg)
9. Whole Bean Coffee – 7.7 lbs. (3.5 kg)

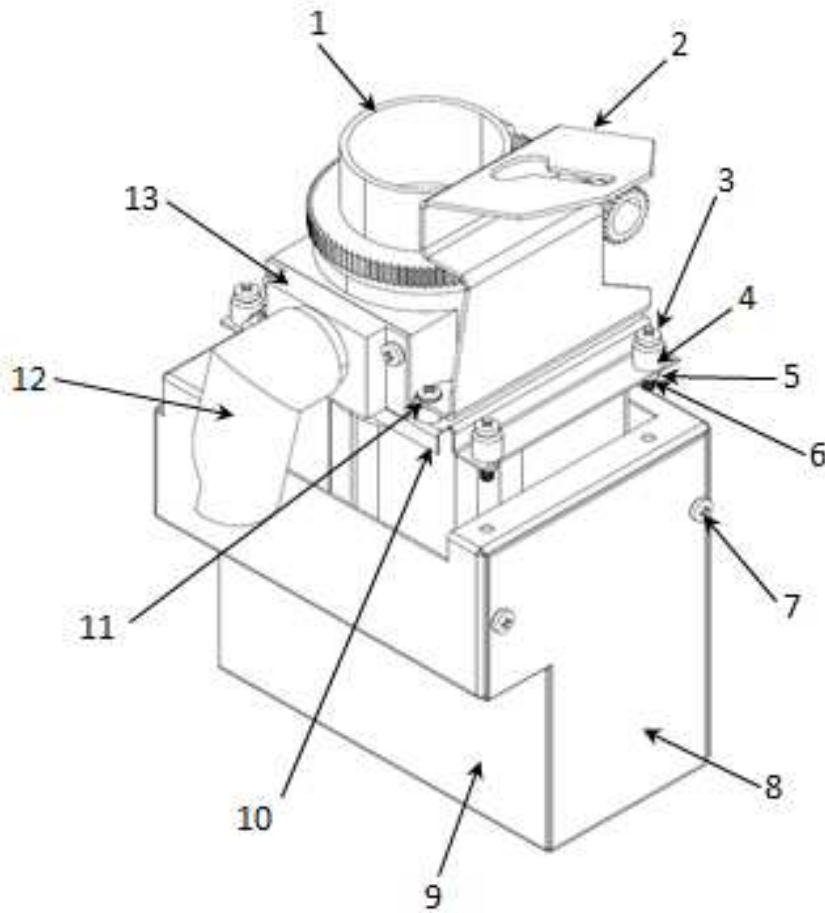
(607) B2C GRINDER ASSY.

(607) B2C GRINDER ASSY.

REF #	PART #	DESCRIPTION
1	MO10955000	GRINDER & MOTOR - 120VAC
2	CR0024839	SUPPORT BRACKET, BEAN CANISTER
3	FA01502000	SCREW, M4 X 6 POZI PAN
4	ME10988000	M/F BOBBIN MOUNT M4
5	FA01506000	NUT, M4 HEX FULL
6	FA04422000	M4 STEEL EXT. SHAKE PROOF WASHER
7	80030438	SCREW, R, 8-32 x 3/8 TYPE 1, HEX WASHER B
8	CR0024838	COVER GRINDER MODULE
9	CR0024841	MODULE, GRINDER
10	CR0024849	MOUNTING BRACKET - GRINDER MOTOR
11	FA04340000	SCREW, M4 X 16 POZI PAN REC
12	CR0026395	CANISTER CHUTE, RH - LONG
13	PL14169000	TRANSITION CHUTE, GRINDER
***	LO14225000	LOOM, GRINDER - VOCE (see page 41)
***	CR0024836	MODULE, INFILL (see page 42)
***	FA05643000	BLANKING PLUG 30MM (see page 40)
		*** INDICATES NOT SHOWN IN DRAWING

SUREVEND™ EMITTER SENSOR

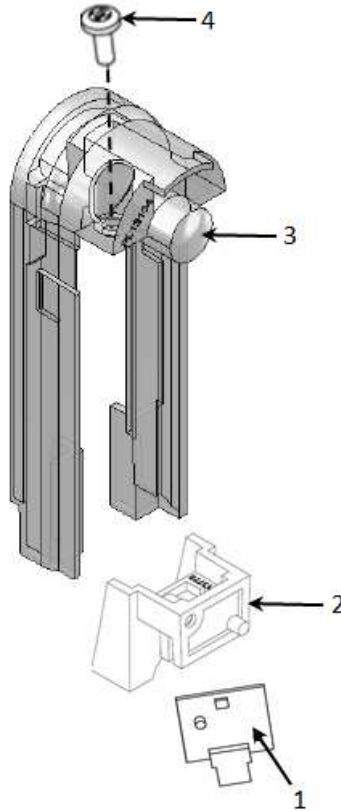

REF #	PART #	DESCRIPTION
1	EL13152000	PCB CUP SENSOR - VOCE SP (sold as a pair)
2	PL13779000	BRACKET, SUREVEND RH - VOCE SP
3	PL13134000	LENS CUP SENSOR - VOCE SP
4	FA13304000	SCREW, K40 X 10 PT TORX - VOCE SP

SUREVEND™ DETECTOR, RH

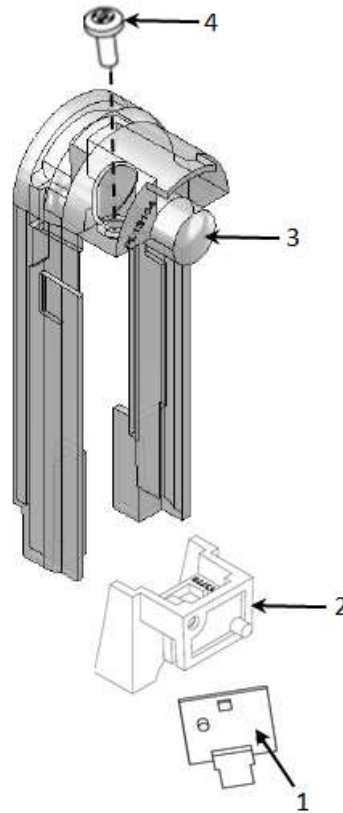

REF #	PART #	DESCRIPTION
1	EL13152000	PCB CUP SENSOR - VOCE SP (sold as a pair)
2	PL13778000	BRACKET, SUREVEND - LH
3	PL13134000	LENS CUP SENSOR - VOCE SP
4	FA13304000	SCREW, K40 X 10 PT TORX - VOCE SP

ELECTRONICS PANEL

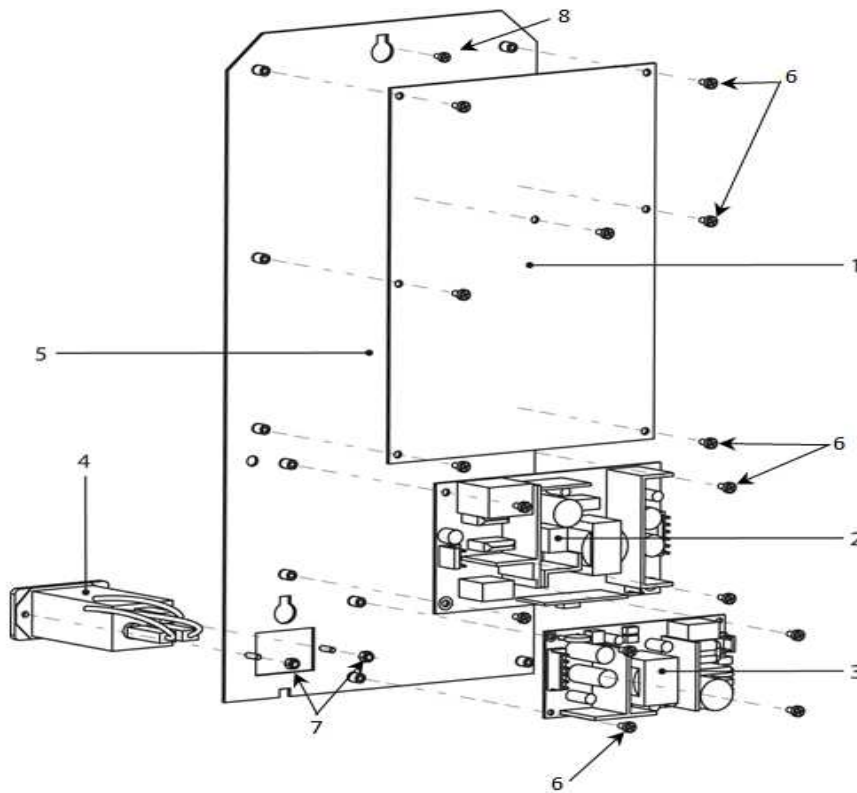

REF #	PART #	DESCRIPTION
1	EL13059001	I/O BOARD VOCE MEDIA
2	EL14585000	POWER SUPPLY, SMPSU 24VDC
3	EL13165000	POWER SUPPLY, SMPSU 12VDC
4	613EL13175000	FILTER MAINS - IEC TYPE
5	MT13077000	PLATE - I/O CIRCUIT BOARD
6	FA01498000	POZI PAN SCREW, M3 x 6
7	FA11774000	SELF-LOCKING NUT, M3
8	FA04431000	SCREW, M5 x 10 TAPTITE POZI PAN HEAD

FUSE & RELAY PANEL

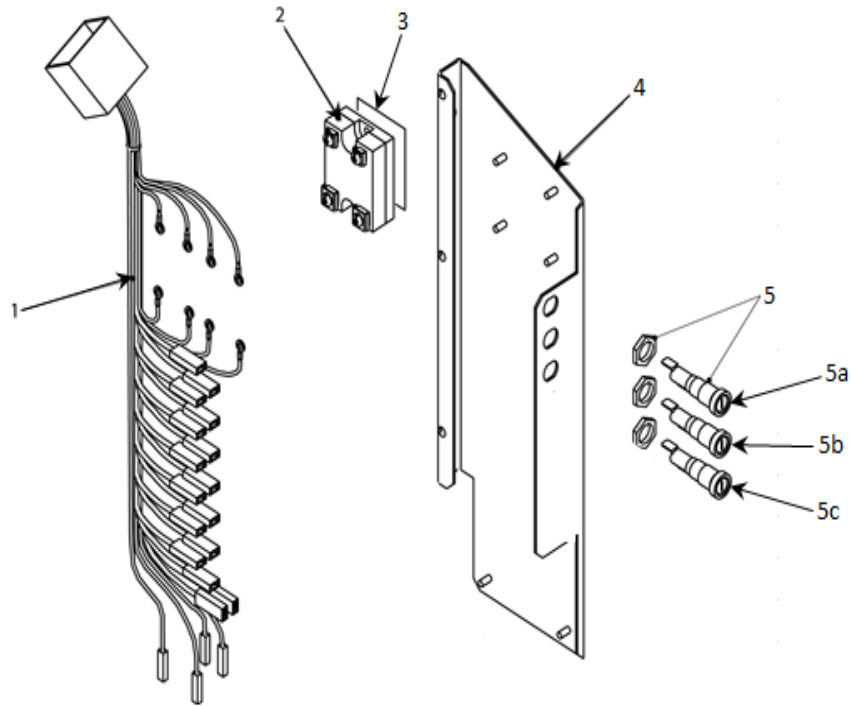

REF #	PART #	DESCRIPTION
1	LO13653001	EVO/INF PSU LOOM - INSTANT / FB VOCE
2	613EL01152002	HEATER RELAY SSR, 25A
3	EL13490000	PAD, SSR HEAT TRANSFER
4	MT13078000	BRACKET, PSU
*5	EL01994000	GENERIC FUSE HOLDER ASSY.
5a	EL01995000	FUSE, 12A - 250V
5b	EL0277000	FUSE, 4A
5c	EL14845000	FUSE, 3.2A / 250V SLO-BLOW

DISPENSE HEAD ASSEMBLY

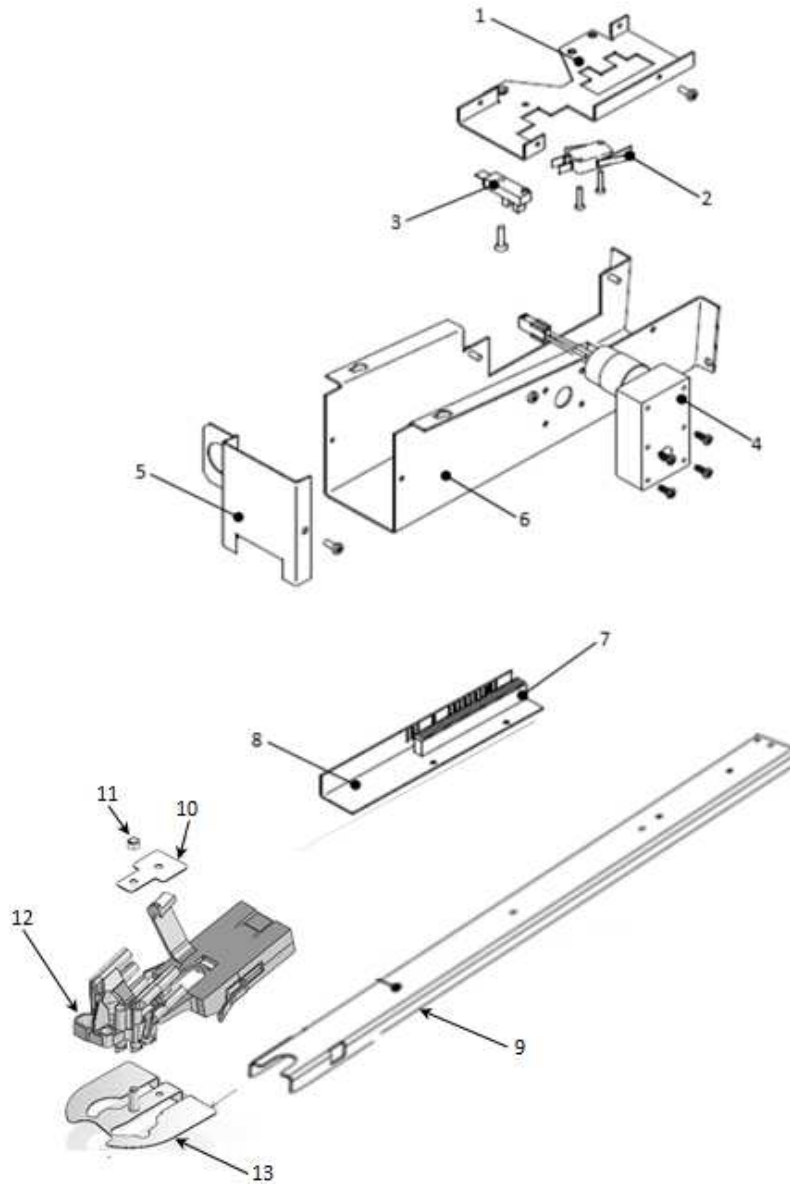

DISPENSE HEAD ASSEMBLY

REF #	PART #	DESCRIPTION
***	VM DISP HEAD US	VM DISPENSE HEAD - US ASSY.
1	MT10695000	CHANNEL, DISPENSE HEAD
2	613EL04920000	SWITCH & LEVER, CHERRY DISP HEAD
3	613EL10036000	OPTO DEVICE, DISPENSE HEAD SV
4	613MO10794000	MOTOR, 24VDC, 50 RPM
5	MT10696080	FRONT COVER, DISPENSE HEAD
6	MT10694000	BODY, DISPENSE HEAD
7	PL10035000	RACK, MOULDING, DISPENSE HEAD
8	MT10697000	CODE ANGLE, DISPENSE HEAD
9	MT13826250	DISPENSE HEAD ARM
10	MT14110290	CLAMPING PLATE - DISPENSE HEAD - US
11	FA11770000	M5 NYLOC STAINLESS STEEL NUT
12	PL13345000	DISPENSE HEAD MOULDING
13	MT14107290	BLANKING PLATE DISPENSE HEAD - US
***	PH05501000	NOZZLE SET MOULDED *
***	LO11751000	DISPENSE HEAD LOOM *
***	613LO14635000	MOTOR LINK C/N 100nF CAP *
	* INDICATES	ITEMS THAT ARE NOT ILLUSTRATED

TURRET and CDU ASSEMBLY

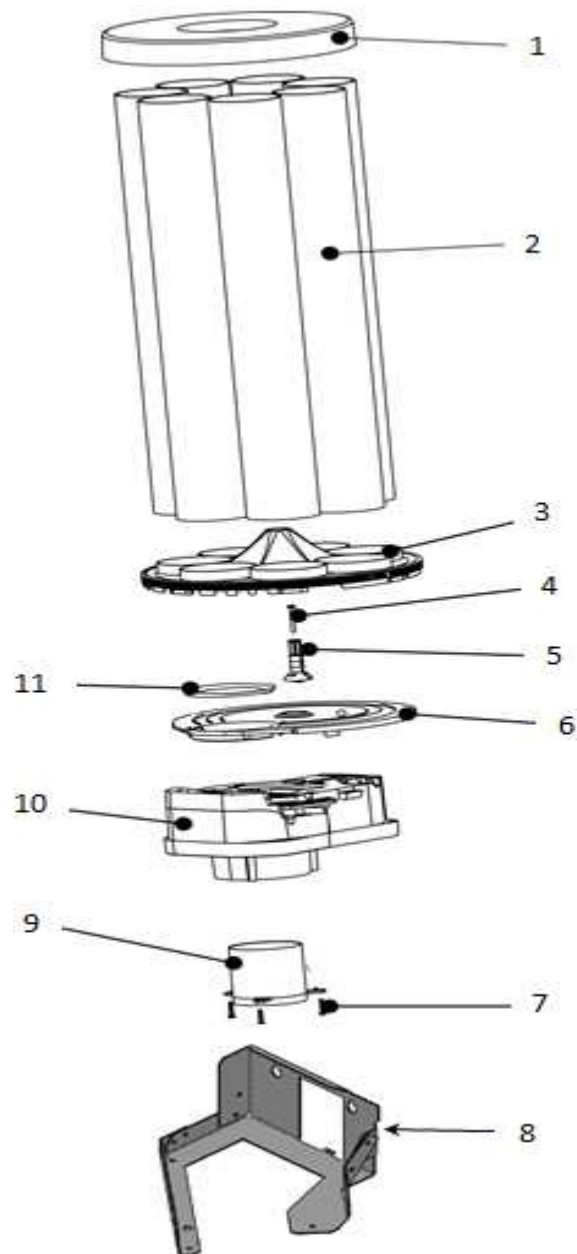

TURRET and CDU ASSEMBLY

REF #	PART #	DESCRIPTION
1	(a) CR0025221	TURRET LID, 5 stack (90mm cups)
	(b) CR0025222	TURRET LID, 6 stack (80mm cups)
	(c) PL13839000	TURRET LID, 7 stack (70/73mm cups)
2	(a) PL13873000	TUBE, 12oz. / 16oz. TURRET, VOCE - (SMR CUPS)
	(b) PL13842001	TUBE, 12oz. TURRET, VOCE - (SVS CUPS)
	(c) PL13840001	TUBE, TURRET 7oz./8oz./9oz. - VOCE (SVR CUPS)
3	(a) PL13844000	CAROUSEL, 5 STACK 306mm, VOCE - SP
	(b) PL13836000	CAROUSEL, 6 STACK INSERT - VOCE SP
	(c) PL13703000	CAROUSEL, 7 STACK 306mm - VOCE SP
4	FA04340000	SCREW, M4 x 16 POZIPAN REC
5	PL13692000	CAROUSEL PIN TOP
6	PL13702000	CAROUSEL PLATE 306mm
7	PL01973000	PT PAN SCREW - M4 x 20
8	CR0026350	BRACKET, CDU MOUNT, VOCE
9	PL13843000	80mm (12oz.) CUP THROAT (not used on 2a)
10	ME14045000	CDU ASSEMBLY
11	(a) PL14475000	CUP REDUCING RING (70/73mm)
11	(b) PL14476000	CUP REDUCING RING (80mm)
*	CR0023497	CDU & TURRET, 6 STACK ASSEMBLY-COMPLETE
*	CR0023572	CDU & TURRET, 5 STACK ASSEMBLY-COMPLETE
*	CR0023573	CDU & TURRET, 7 STACK ASSEMBLY-COMPLETE

CMS WHIPPER MIXING SYSTEM

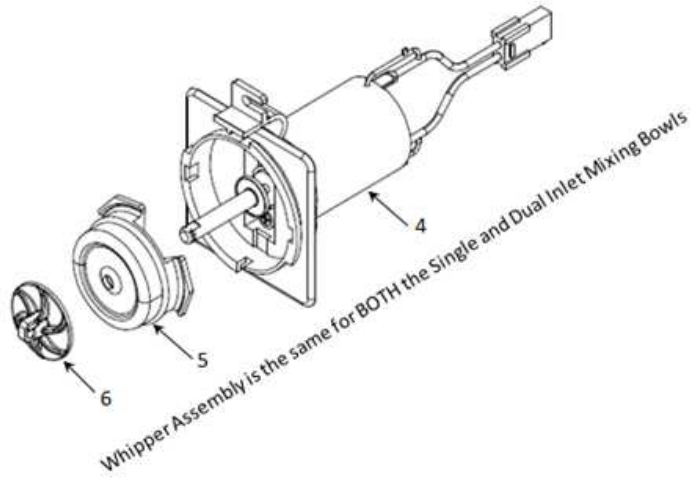
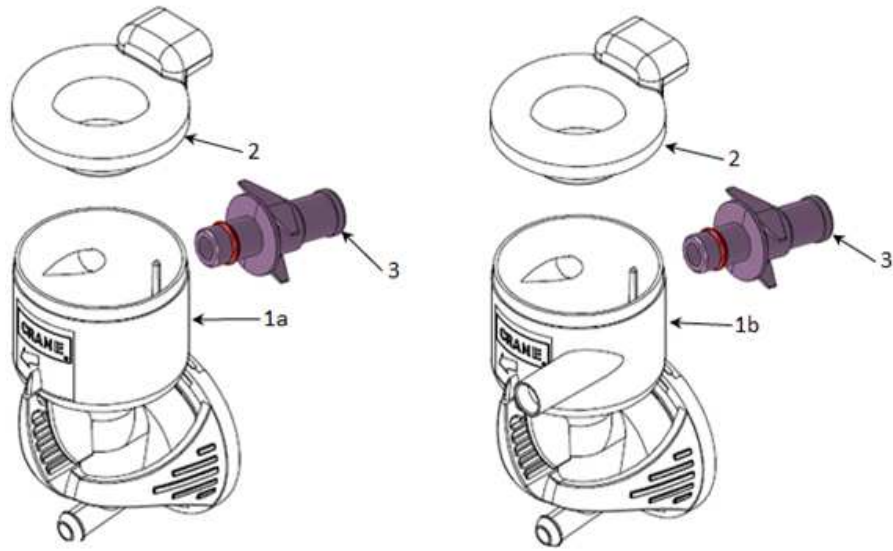

CMS WHIPPER MIXING SYSTEM

REF #	PART #	DESCRIPTION
*	*****	CMS WHIPPER MIXING SYSTEM
1a	ME14043000	MIXING BOWL, SINGLE INLET - VOCE SP
1b	613ME14044000	DUAL INLET MIXING BOWL - VOCE SP
2	PL13725000	STEAM HOOD, CMS MIXING SYSTEM
3	ME14548000	ASSY, ADAPTOR BOWL - VOCE SP
4	ME13729	CMS MIXING SYSTEM, MOTOR ASSY.
5	PL13728000	SEAL, WHIPPER BOWL
6	PL13723000	IMPELLER, CMS MIXING SYSTEM

NESTLÉ WHIPPER MIXING SYSTEM

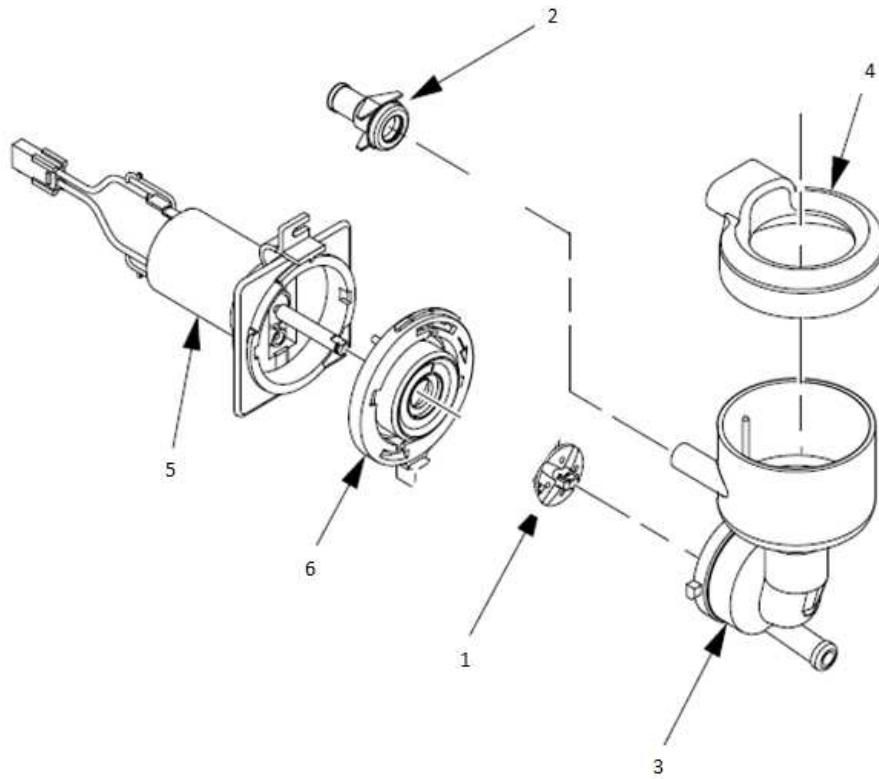

REF #	PART #	DESCRIPTION
*	*****	NESTLÉ MIXING SYSTEM
1	6927003	IMPELLER - WHIPPER - BLACK
2	6927004	BULKHEAD - MIXING BOWL
3	6927005	MIXING BOWL-WHIPPER HOUSING-BLACK
4	6927006	CAP - MIXING BOWL - BLACK
5	CR0013658	CASIC - WHIPPER MOTOR ASSY.
6	CR0021640	COLLAR, LOCKING, WHIPPER

WATER TANK ASSEMBLY

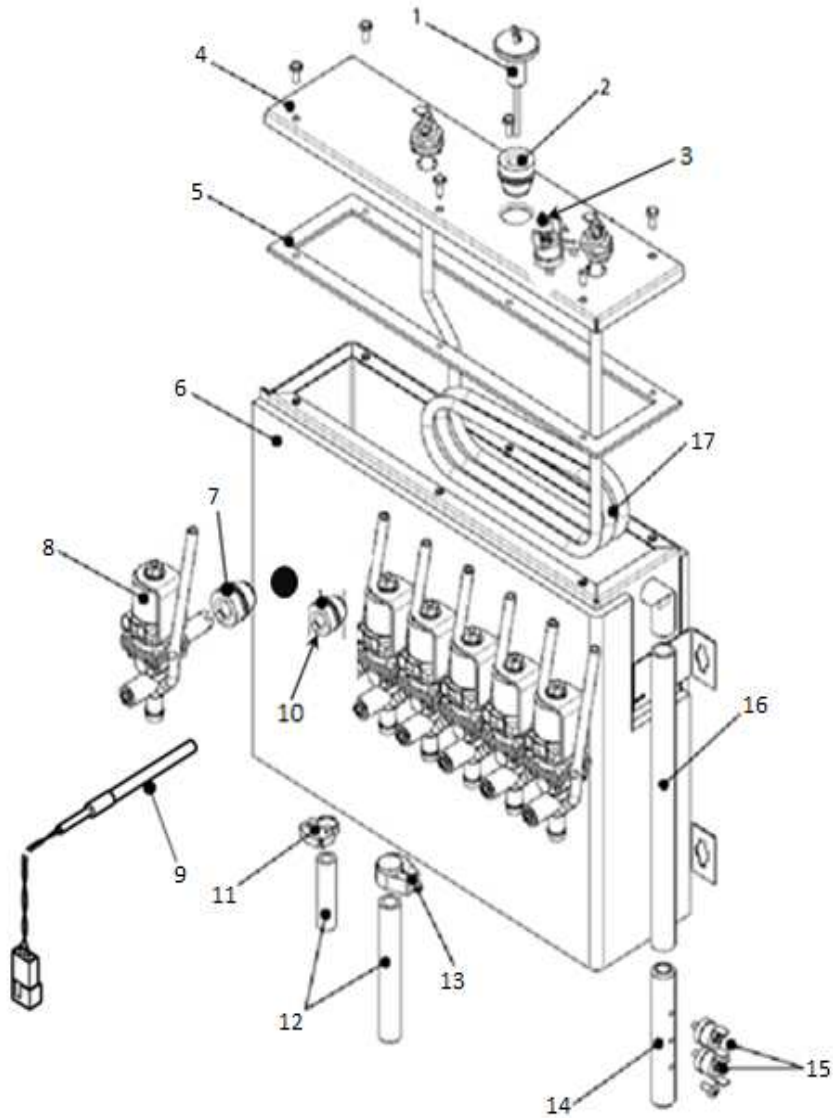

WATER TANK ASSEMBLY

REF #	PART #	DESCRIPTION
1	613ME04550000	PROBE ASSY, LEVEL, TOP
2	SI06340000	SEAL PORT, THERMISTOR
3	613EL10954000	BOILER, TEMPERATURE CUT-OUT
4	MT14667000	BOILER, LID
5	613SI10627960	BOILER SEAL, 8 PORT, BOILER
6	BA14666000	A, BOILER, 8 PORT, REV INLET VOCE SP
7	VA03377002	SEAL PORT, VALVE, (A.u.K MÜLLER)
8	VA10148002	VALVE DISPENSE, 24VDC (A.u.K MÜLLER)
*	VA01838A00	VALVE, DISPENSE, REPAIR/REBUILD KIT (A.u.K MÜLLER)
*	6050002	KIT, VALVE & SEAL (A.u.K MÜLLER)
9	613EL03112000	PROBE THERMISTOR
10	SI06340000	SEAL, BOILER, BLANK (has Hole for Probe)
11	FA01185000	SNAPPER CLIP, 30
12	613SI01171960	SILICON PIPE, 8MM x 12.5MM
13	FA03227000	UNIX CLIP, 19MM
14	ME03024001	HOLDER, SENSOR 3 HOLES
15	613EL03378000	TEMPERATURE CUT-OUT
16	SI01142960	SILICON PIPE, 12MM x 16MM
17	613EL13888000	ELEMENT, 1200W, 120VAC - USA
*	SI08276000	SEAL, BOILER, BLANK (NO HOLE)
*	BA14364000	PAD, INSULATION WRAP-A-ROUND
*	SI04345960	PIPE, SILICONE 6MM / 9.5MM
*	3618123	TUBING-U.K.-AQUAVEND-.375 ID (this is the tubing from the Water Inlet Valve to the Tank Lid Assy.)

OLTRE BREWER - FRESHBREW USA

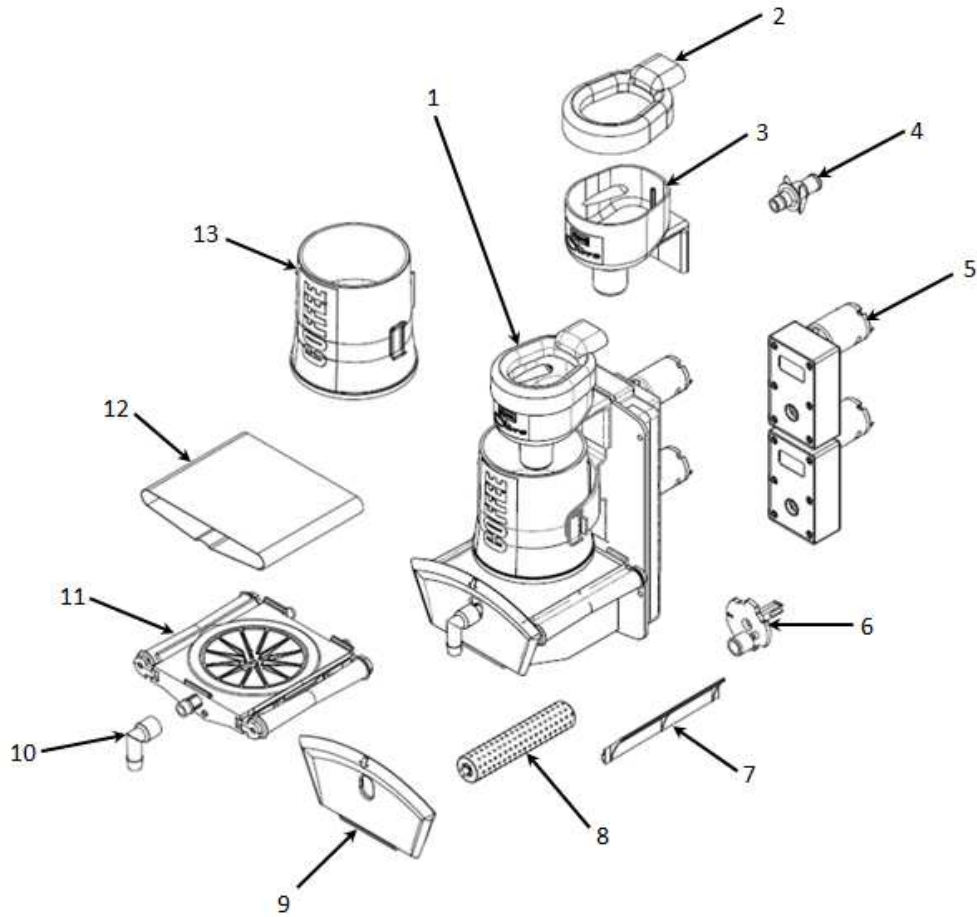

OLTRE BREWER - FRESHBREW USA

REF #	PART #	DESCRIPTION
1	613ME13414000	BREWER ASSY., OLTRE 83MM, COMPLETE
2	613PL13454000	STEAM TRAP FOR BREWER
3	PL13455	MIXING BOWL
4	613PL13456000	ADAPTOR, BOWL
5	MO13457	CASIC MOTOR, 24VDC, ZYT28T-CS-014
6	PL13452	SHAFT, GEAR MTR, DRIVES SUPPORT CHAMB.
7	PL13450000	CLEANING RIBBON (RIGHT SIDE ONLY)
8	ME15106000	OLTRE BREWER DRIVE ROLLER, KIT
9	PL13451000	RELEASE HANDLE
10	613PL13478000	SPOUT ID6 FOR COFFEE
11	613ME13463000	COFFEE BELT ASSY. - 83MM
12	613ME13480000	COFFEE BELT FILTER- SINGLE (PART OF #11)
12	613ME13713000	COFFEE BELT FILTER- 6 PACK (PART OF #11)
13	613PL13469000	LOWER CHAMBER ASSY., COFFEE ID83
*	LO13496	BREWER LOOM (not shown)
*	613ME13438000	O-RING FOR SPOUT ELBOW (PART OF #10)

EXHAUST FAN ASSEMBLY

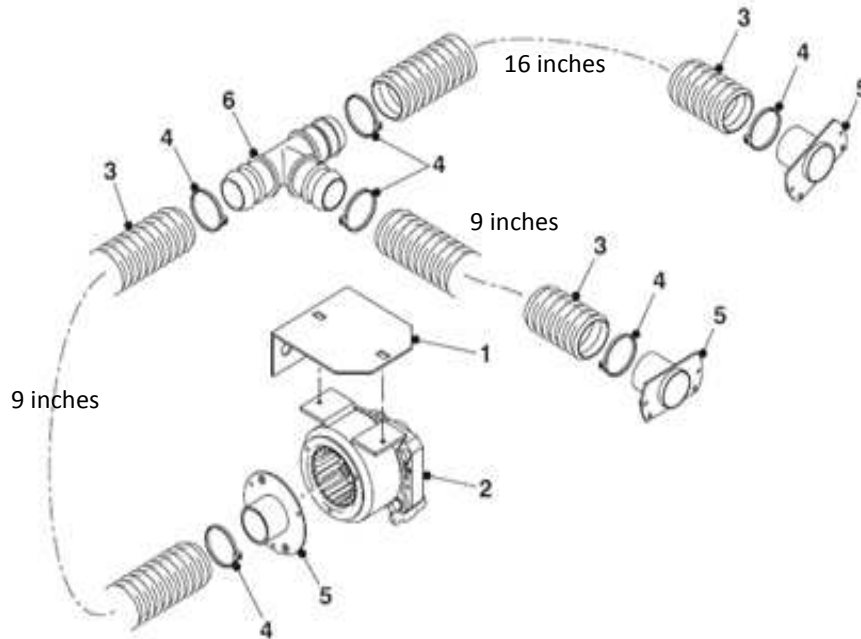

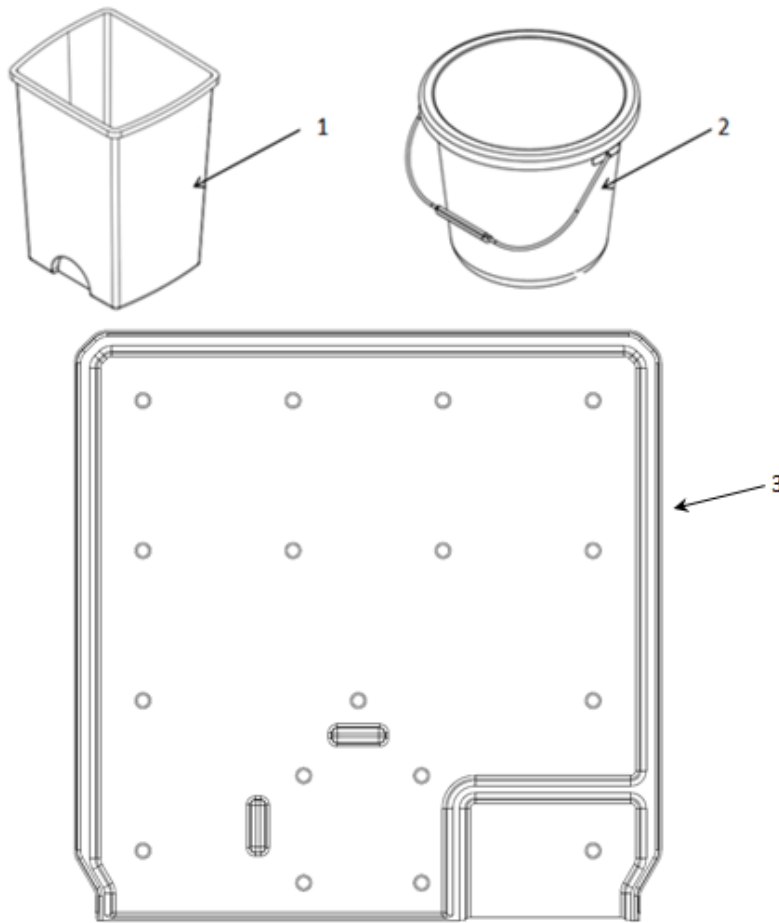

REF #	PART #	DESCRIPTION
1	MT14287000	MOUNTING BRACKET, EXTRACT FAN
2	613ME10956000	EXTRACT FAN, 120VAC, USA
3	HO01139000	HOSE, DUCTING RIBBED BLACK (a total of 34 Inches are needed)
3a		1 - 9" (goes from the Extract Fan to the Tee)
3b		1 - 9" (goes from the Tee to the Left-hand side of the Exhaust Tray)
3c		1 - 16" (goes from the Tee to the Right-hand side of the Exhaust Tray)
4	FA01188000	CABLE TIE
5	PL03083000	EXTRACT HOSE ADAPTOR
6	PL04165000	'T' PIECE - 11/4"
*	ME10944000	MESH SCREEN, 14 x 14, 0.02" (see page 38)

LIQUID & GROUNDS BUCKETS / FLOOR LINER



REF #	PART #	DESCRIPTION
1	PL06672000	BUCKET, 24L FB WASTE - GREY
2	PL01172000	BUCKET, 9L, SILVER
3	CR0027483	MODIFIED VOCE FLOOR LINER

MISCELLANEOUS PARTS

REF #	IMAGE	PART #	DESCRIPTION
1		6118071	EVERPURE CARTRIDGE WATER - FILTER - 4H
2		6738047	HYDRO LIFE HLV192AD ADAPTER KIT
3		3158023	BRACKET-MOUNTING-WATER FILTER
4		1679056	HARNESS, DEX INTERFACE
5		FA04301000	M4 x .7 KNURLED THUMB NUT
6		ME03333000	KEY, CASH BOX #300245
7		613PL04589000	CUP STAND
8		CR0023374	BEZEL, CARD READER BLANK
9		CR0023375	BRACKET, BLANK SWIPE
10		3104056	STRAIN RELIEF BUSHING - HEYCO

MISCELLANEOUS PARTS

REF #	IMAGE	PART #	DESCRIPTION
11		FA03262000	M4 SELF-LOCKING NUT, NYLOC
12		EL14779000	PCB, ATM, BUTTON ASSY. (WHITE LED'S)
13		FA11188000	M4 x 35 POZI PAN SCREW
14		FA01498000	M3 x 6 POZI PAN REC. SCREW
15		FA01505000	M5 x 6 PAN HEAD SCREW
16		FA02142000	M5 EXT. CER. S/PROOF 11 ZP
17		FA03124000	M8 FULL NUT HEX XP
18		FA03126000	M8 SPRING TYPE 'A' WASHER
19		FA03197000	M4 EXT. SHAKEPROOF WASHER
20		FA03215000	M8 STEEL FORM 'A' WASHER ZP

MISCELLANEOUS PARTS

REF #	IMAGE	PART #	DESCRIPTION
21		FA04320000	SPIRAL WRAP - PLASTIC
22		FA04431000	M5 x 10 TAPTITE POZI PAN HD
23		FA05643000	BLANKING PLUG 30MM
24		FA07905000	FIR TREE BUTTON BLACK
25		FA14699000	M4 x 25 POZI PAN REC. SCREW
26		FA13304000	SCREW, K40 x 10 PT TORX
27		FA13305000	NUT, M5 HEX, FLANGED NYLOC
28		FA13359000	'D' TYPE SCREW LOCK SET
29		FA13683000	TWIST LOCK C/W STANDOFF
30		FA13838000	M8 x 20 CSK SKT BZP

MISCELLANEOUS PARTS

REF #	IMAGE	PART #	DESCRIPTION
31		FA14036000	FOOT BUCKET STOP
32		FA14965000	GROMMET RUBBER SEMI BLIND
33		ME10988000	M/F BOBBIN MOUNT M4
34		GR13141000	FACIA, FLAP COIN, STAINLESS
35		CR0025177	GASKET, 8.4" LCD DISPLAY (25 inches needed)
36		LO15068000	HARNESS, MEDIA ATM LOOM
37		CR0025331	MAINS LEAD IEC - USA
38		LO14225000	LOOM GRINDER - VOCE
39		LO15769000	ATM COMMS LOOM
40		LO15067000	HARNESS, MEDIA DOOR LOOM







MISCELLANEOUS PARTS

REF #	IMAGE	PART #	DESCRIPTION
41		613ME13480000 613ME13713000	COFFEE BELT FILTER-SINGLE COFFEE BELT FILTER-6 pack
42		ME14955000	CONNECTOR 3/8" TUBE x 1/4"
43		ME14956000	ELBOW 3/8" TUBE x 3/8" STEM
44		HO03674001	SPRAY HEAD HOSE ASSY.
45		CR0024836	MODULE INFILL
46		CR0024968	ASSY., BRACKET, CUP STAND
47		CR0024845	ASSY., PLATE, COVER
48		CR0024832	A, BRACKET, CDU MOUNTING with PEM
49		CR0025933	BRACKET, DISPLAY MOUNTING with PEM
50		CR0026548	ASSY., CUP CATCHER

MISCELLANEOUS PARTS

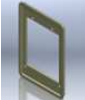
REF #	IMAGE	PART #	DESCRIPTION
51		CR0025138 CR0025162	PLATE, CARD READER MOUNTING ASSY., VALIDATOR
52		CR0024837	BAND, TURRET, CDU
53		CR0024824	COVER, LH, ATM - VOCE MEDIA
54		CR0024825	COVER, RH, ATM - VOCE MEDIA
55		PL01973000	SCREW, M4 X 20 PT PAN
56		PL10274000	GRILL DRIP TRAY
57		PL15121000	VEND AREA, 90MM
58		PL13776000	BRACKET CUP CATCHER
59		PL13147000	CLIP, CUP CATCHER
60		PL13802000	DRIP TRAY VOCE ROUTING

MISCELLANEOUS PARTS

REF #	IMAGE	PART #	DESCRIPTION
61		PL11696000	BUNG, CANISTER
62		PL13140000	COIN FLAP
63		PL13784000	GLASS FIXING WASHER
64		PL14578000	BEZEL, BLANKING PANEL
65		CR0025159	ASSY., CARD READER MOUNTING
66		CR0025912	DECAL SET, INTERIOR-ENGLISH
67		PR14282000	LABEL, CAUTION - HOT BEVERAGE
68		6921108	LABEL, CAUTION HOT SURFACE
69		6920051	LABEL, BACKFLOW PROTECTION
70		PA13650000	TUBING, PERISTALTIC PUMP

MISCELLANEOUS PARTS

REF #	IMAGE	PART #	DESCRIPTION
71		6921104	LABEL, WARNING, HIGH VOLTAGE
72		80388542	LABEL, R, NOTICE, GFCI, EQUIPMENT MACHINE
73		80388518	LABEL, R, WARNING GFCI POWER CORD, ENGLISH
74		CR0024850	NUT, RIVET, M4 x 0.7
75		ME04373000	PILE WEATHER STRIP-GREY
76		FA01502000	SCREW, M4 X 6 POZI PAN Z.P.
77		FA04422000	M4 STEEL EXT SHAKEPROOF
78		FA01506000	NUT, M4 HEX FULL
79		FA04340000	SCREW, M4 x 16 POZIPAN REC
80		80030534	SCREW, (used on Grinder Assy.)

MISCELLANEOUS PARTS

REF #	IMAGE	PART #	DESCRIPTION
81		CR0026406	SUPPORT BRACKET, (for 8lb. Bean Canister)
82		1870850	K, LINE SOLO CDMA, VERIZON
83		6738051	FILTER HEAD, EVERPURE, #9259-24A
84		1679054	MDB HARNESS, COIN & VALIDATOR
85		6732247	BOLT-TEE #8-32 x 1.375
86		CR0025240	SPACER, CUP RING ARM
87		CR0025242	NUT, THUMB, CUT RING
88		4042121	WIRE TIE - #PLT1M-M20
89		CR0026225	PLATE, w/PEM, MOUNTING
90		CR0026333	BRACKET, TRANSITION, INTEGRATED

MISCELLANEOUS PARTS

REF #	IMAGE	PART #	DESCRIPTION
91		80490261	GROUND, R, WIRE 4in. GREEN
92		CR0028660	ASSY., PCB, LED
93		CR0026222	BRACKET, LED, INTEGRATED
94		80190380	STANDOFF, R, RICOH, RL
95		AP4200096	CABLE CLAMP, SELF ADHESIVE
96		CR0025245	BRACKET, with PEM, (for attaching Polycarbonate Door)
97		ME10944000	MESH SCREEN for EXHAUST FAN
98		PL14475000	CUP REDUCER RING, 70-73mm
99		PL14476000	CUP REDUCER RING, 78-80mm
100		MA15717000	CABINET CANISTER FILL, BRACKET ASSY.

MISCELLANEOUS PARTS

REF #	IMAGE	PART #	DESCRIPTION
101		EL13158002	ATLAS PCB, VOCE MEDIA w/FIRMWARE
102		PL13774000	TRAY, VEND AREA
103		ME01859000	CASHBOX, LOCK & KEY
104		MT06635	LOCK CAM, CASHBOX
105		AP420295	CARRIAGE BOLT - SHORT
106		CR0026526	STANDOFF, MALE-FEMALE
107		CR0027629	VALVE, CHECK, DUAL 3/8"
108		FA01118800	M4 x 35 POZI PAN SCREW
109		CR0025502	BRACKET, CANISTER ALIGNMENT, (SBC option)
110		CR0028215	PLATE ASSY., FILTER HEAD

MISCELLANEOUS PARTS

REF #	IMAGE	PART #	DESCRIPTION
111		CR0026529	NUT, M5 x 0.8, 2.7MM, THK
112		6056006	KIT, CONVERTING GLASS TO POLYCARBONATE
113		EL10025002	PROGRAMMING KEYPAD
114		CR0026399	COVER, ATLAS BOARD
115		MT15089	ATLAS 'G' MOUNTING PLATE
116		CR0014114	ASSY, PCB, LED DRIVER, GLOBAL
117			
118			
119			
120			

MISC. NUTS, SCREWS & WASHERS

PART #	DESCRIPTION
FA10203000	NUT, M3 NYLOC
FA01499000	NUT, M3 PLAIN ZP
FA01498000	SCREW, M3 X 6 POZI PAN
FA10205000	SCREW, M3 X 10 POZI PAN
FA05206000	SCREW, M3 X 16 CSK
FA01503000	CREW, M3 X 16 POZI PAN
FA04422000	WASHER, M4 SHAKEPROOF
FA01501000	WASHER, M4 PLAIN
FA01506000	NUT, M4 HEX FULL
FA03262000	NUT, M4 SELF-LOCK NYLOC
FA03289000	NUT, M4-0.7 JAM NUT 2
FA01502000	SCREW, M4 X 6 POZI PAN ZP
FA02431000	M4 X 8 POZI PAN STAINLESS
FA10807000	SCREW, M4 X 10 LG POZI PAN
FA01504000	SCREW, M4 X 10 POZI PAN
FA01143000	SCREW, M4 X 10 SET STAINLESS
FA07111000	SCREW, M4 X 10 THUMB
FA04340000	SCREW, M4 X 16 POZI PAN REC
FA02029000	SCREW, M4 X 20 POZI PAN
FA04301000	NUT, M4 x .7 KNURLED THUMB

MISC. NUTS, SCREWS & WASHERS

PART #	DESCRIPTION
FA01507000	WASHER, M5 PLAIN
FA01555000	WASHER, M5 SHAKEPROOF - SS
FA01508000	NUT, M5 FULL ZP
FA01683000	NUT, M5 NYLOC ZP
FA13305000	NUT, M5 FLANGED NYLOC
FA01509000	SCREW, M5 X 10 POZI PAN
FA04431000	SCREW, M5 X 10 TAPTITE
FA05210000	SCREW, M5 X 10 CHEESE HEAD
FA01682000	SCREW, M5 X 16 POZI PAN
FA10863000	BOLT, M5 X 25 CARRIAGE
FA01416000	NUT, M5 SKIFFY THUMB
FA01561000	WASHER, 1/4 ZP PLAIN
FA01487000	FASTON CONNECTOR-1/4"
FA01488000	FASTON CONNECTOR BOOT-1/4 "
FA01489000	SPADE CONNECTOR-1/4"
FA14890000	SPADE CONNECTOR BOOT
FA01188000	CABLE TIE-MEDIUM
FA01860000	CABLE TIE-SMALL
FA01189000	CABLE TIE HOLDER
FA10222000	PCB SUPPORT
FA03227000	UNEX CLIP 19MM

PART NUMBER - PAGE INDEX

PART #	DESCRIPTION	PAGE
1236050	SWITCH, DOOR	8
1671090	COIN BOX	6
1679054	HARNESS, "MDB" COIN & VALIDATOR	46
1679056	HARNESS, DEX INTERFACE	38
1870850	K, LINE SOLO CDMA VERIZON RADIO	46
3104056	STRAIN RELIEF BUSHING - HEYCO	38
3158023	BRACKET, MOUNTING, WATER FILTER	38
3618123	TUBING - U.K. - AQUAVEND - .375 ID	33
4042121	TIE, WIRE, PLASTIC, #1M-M20	46
6050002	KIT, VALVE & SEAL (A.u.K. MÜLLER) - 24VDC	8, 33
6050006	KIT, GLASS TO POLYCARBONATE	49
6118071	CARTRIDGE - WATER - FILTER - 4H EVERPURE	8, 38
6408134	FILTER HEAD, EVERPURE	8
6732247	BOLT-TEE #8-32 X 1.375, LARGE	46
6738047	HYDRO LIFE HLV192AD ADAPTER KIT	8, 38
6738051	FILTER HEAD, EVERPURE, #9259-24A	46
6920051	LABEL, BACKFLOW PROTECTION	44
6921104	LABEL-WARNING-HI VOLTAGE-SP/ENG	45
6921108	LABEL, CAUTION-HOT SURFACE-SP/ENG	44
6927003	IMPELLER - WHIPPER - BLACK... (NESTLÉ)	31
6927004	BULKHEAD - MIXING BOWL... (NESTLÉ)	31
6927005	MIXING BOWL - WHIPPER HOUSING - BLACK... (NESTLÉ)	31
6927006	CAP - MIXING BOWL - BLACK... (NESTLÉ)	31
80030438	SCREW, R, 8-32 x 3/8 TYPE 1	20
80030534	SCREW, R, 8-32 x 5/16 PHILIPPS N TYPE W	45
80190380	STANDOFF, R, RICHC0, RLCBSR401SRB	47
80388518	LABEL, R, WARNING, GFCI, POWER CORD, ENGLISH	45
80388542	LABEL, R, NOTICE, GFCI, EQUIPMENT, MACHINE	45
80490261	GROUND, R, WIRE 4", GREEN/YELLOW	47
613EL01152002	HEATER RELAY SSR, 25A	24

PART NUMBER - PAGE INDEX

PART #	DESCRIPTION	PAGE
613EL03112000	PROBE THERMISTOR	33
613EL03378000	TEMPERATURE CUT-OUT	33
613EL04920000	SWITCH & LEVER, CHERRY DISPENSE HEAD	26
613EL10036000	OPTO DEVICE, DISPENSE HEAD SV	26
613EL10954000	BOILER, TEMPERATURE CUT-OUT	33
613EL13175000	FILTER MAINS - IEC TYPE	20
613EL13888000	ELEMENT, 1200W, 120VAC - USA	33
613LO14635000	MOTOR LINK C/N 100nF CAP	26
613ME04550000	PROBE ASSY, LEVEL, TOP	33
613ME10956000	EXHAUST FAN, 120VAC, USA	8, 35
613ME13414000	BREWER ASSY., OLTRE 83MM, COMPLETE	9, 15, 35
613ME13463000	COFFEE BELT ASSY. - 83MM	35
613ME13480000	BELT FILTER-COFFEE, SINGLE	42
613ME13713000	BELT FILTER-COFFEE (6 PK)	42
613ME14044000	DUAL INLET MIXING BOWL	30
613MO10794000	MOTOR, 24VDC, 50 RPM	26
613MT13039000	BUCKET SUPPORT, SIDE RAIL	8
613MT13914340	MODULE, EXTRACT TRAY, (TFB)	8, 9, 15
613MT14400000	WASTE CHUTE, OLTRE BREWER, RH	9,15
613PL04589000	CUP STAND	38
613PL13454000	STEAM TRAP FOR BREWER (CMS MIXING SYSTEM)	35
613PL13456000	ADAPTOR CRANE	35
613PL13469000	LOWER CHAMBER ASSY., COFFEE ID83	35
613PL13478000	SPOUT ID6 FOR COFFEE	35
613SI01171960	SILICON PIPE, 8MM, ID	33
613SI10627960	BOILER SEAL, 8 PORT, BOILER	33
613VA11700000	VALVE INLET 24V DC DOUBLE	8
AB DISP HEAD	COMPLETE DISPENSE HEAD ASSEMBLY	20
AP420096	CABLE CLAMP-ADHESIVE BACK, 3/4	47
AP420295	BOLT, CARRIAGE 1/4-20 X 1/2	48

PART NUMBER - PAGE INDEX

PART #	DESCRIPTION	PAGE
BA14364000	BOILER INSULATION PAD	33
BA14666000	BOILER, 8 PORT, REV INLET	33
CR0012773	INSERT, COIN RAMP - MERCHANT/BEVMAX-G	4
CR0013658	CASIC - WHIPPER MOTOR ASSY... (NESTLÉ)	31
CR0014114	ASSY, PCB, LED DRIVER - GLOBAL	6, 49
CR0014768	ASSY, CARD READER, AND MAGHEAD, G	4
CR0021640	COLLAR, LOCKING, WHIPPER... (NESTLÉ)	31
CR0023344	CUP CATCHER, 90mm	6
CR0023374	BEZEL, CARD READER BLANK	38
CR0023375	BRACKET, BLANK SWIPE	38
CR0023497	CDU & TURRET, 6 STACK ASSEMBLY-COMPLETE	28
CR0023572	CDU & TURRET, 5 STACK ASSEMBLY-COMPLETE	28
CR0023573	CDU & TURRET, 7 STACK ASSEMBLY-COMPLETE	28
CR0024823	BUCKET STAND, VOCE	8
CR0024824	COVER, LH ATM	43
CR0024825	COVER, RH ATM	43
CR0024832	BRACKET, CDU MOUNTING W/PEM	42
CR0024836	MODULE, INFILL	20, 42
CR0024837	BAND, TURRET, CDU	43
CR0024838	COVER GRINDER MODULE	20
CR0024839	SUPPORT BRACKET, BEAN CANISTER	14, 20
CR0024840	PLATE, KICK	4
CR0024841	MODULE, GRINDER	20
CR0024845	ASSY, PLATE COVER	42
CR0024849	MOUNTING BRACKET - GRINDER	20
CR0024850	NUT, RIVET M4 X 0.7	45
CR0024968	ASSY, BRACKET, CUP STAND	42
CR0025138	PLATE, CARD READER	43
CR0025159	ASSY, CARD READER MOUNTING	44
CR0025162	ASSY, VALIDATOR MOUNTING	43

PART NUMBER - PAGE INDEX

PART #	DESCRIPTION	PAGE
CR0025177	GASKET, 8.4" LCD DISPLAY (25 inches needed)	41
CR0025221	LID, TURRET, 5 STACK	28
CR0025222	LID, TURRET, 6 STACK	28
CR0025225	FULLY INTEGRATED, POLYCARBONATE/PSG	4
CR0025240	SPACER, CUP RING ARM ADJUSTMENT	46
CR0025242	NUT, THUMB, CUT RING ARM, ADJUSTMENT	46
CR0025245	BRACKET, W/PEM, POLYCARBONATE DOOR	47
CR0025331	POWER CORD, GFCI 15A	41
CR0025502	BRACKET, CANISTER ALIGNMENT, (SBC option)	48
CR0025912	DECAL, SET INTERIOR	44
CR0025933	BRACKET, DISPLAY MOUNTING W/PEM	42
CR0026201	STANDARD KNOCKOUT, POLYCARB/PSG	4
CR0026208	2 KNOCKOUT, POLYCARB/PSG	4
CR0026222	BRACKET, LED INTEGRATED BEZEL	47
CR0026225	PLATE W/PEM, MOUNTING, INTEGRATED BEZEL	46
CR0026333	BRACKET TRANSITION INTEGRATED BEZEL	46
CR0026350	BRACKET, CDU MOUNT, VOCE	28
CR0026395	CANISTER CHUTE, RH - LONG	20
CR0026399	COVER, ATLAS BOARD	6, 49
CR0026406	BRACKET, B2C, CANISTER SUPPORT	46
CR0026526	STANDOFF, MALE-FEMALE THREAD	48
CR0026529	NUT, M5 X 0.8, 2.7MM THK	49
CR0026531	CANISTER w/BRACKET, BEAN, LARGE - 8LB.	17
CR0026548	ASSY, CUP CATCHER	42
CR0027431	STANDARD KNOCKOUT W/NO COIN, POLYCARB/PSG	4
CR0027483	LINER, FLOOR	8, 37
CR0027629	VALVE, CHECK, DUAL 3/8 in. NPT	48
CR0028201	BRACKET, DRIP CUP CATCHER	6
CR0028215	PLATE ASSY, FILTER HEAD	48
CR0028398	INTEGRATED W/STANDARD KNOCKOUT, POLYCARB	4

PART NUMBER - PAGE INDEX

PART #	DESCRIPTION	PAGE
CR0028660	BOARD, LED ACCENT	47
EL01994000	GENERIC FUSE HOLDER ASSY.	24
EL01995000	12 AMP FUSE	24
EL0277000	4 AMP FUSE	24
EL10025002	KEYPAD, PROGRAM, VOCE	6 ,49
EL13059001	I/O BOARD (ATLAS)	8, 23
EL13152000	PCB CUP SENSOR - VOCE SP (sold as a pair)	21, 22
EL13158002	ATLAS PCB VOCE MEDIA	6, 48
EL13165000	SMPSU 12 VDC POWER SUPPLY	8, 23
EL13490000	PAD, SSR HEAT TRANSFER	24
EL13908000	ASSY, LED STRIP UPPER - VOCE SP	6
EL13909000	STRIP, LED LOWER - VOCE SP	6
EL14295000	SCREEN 8.4" LCD - VOCE	4
EL14585000	24 VDC POWER SUPPLY	8, 23
EL14779000	PCB ATM BUTTON ASSY.	39
EL14845000	FUSE, 3.2A / 250V SLOW BLOW	18
FA01118800	SCREW, M4 X 35 PZ PAN	48
FA01143000	M4 X 10 SET SCREW, STAINLESS	38
FA01185000	SNAPPER CLIP, 30	33
FA01188000	CABLE TIE, MEDIUM	36
FA01189000	CABLE TIE HOLDER	39
FA01416000	M5 SKIFFY THUMB NUT	39
FA01487000	FASTON CONNECTOR, 1/4"	39
FA01488000	FASTON CONNECTOR BOOT, 1/4 "	39
FA01489000	SPADE CONNECTOR, 1/4"	39
FA01498000	M3 x 6 POZI PAN REC. SCREW	23, 39
FA01499000	M3 NUT PLAIN ZP	38
FA01501000	M4 WASHER, PLAIN	38
FA01502000	M4 X 6 POZI PAN Z.P. SCREW	20, 45
FA01503000	M3 X 16 POZI PAN SCREW	38
FA01504000	M4 X 10 POZI PAN SCREW	38

PART NUMBER - PAGE INDEX

PART #	DESCRIPTION	PAGE
FA01505000	M5 x 6 PAN HEAD SCREW	39
FA01506000	M4 HEX FULL NUT ZP GRADE 8.8	20, 45
FA01507000	M5 WASHER, PLAIN	39
FA01508000	M5 FULL NUT, ZP	39
FA01509000	M5 X 10 POZI PAN SCREW	39
FA01555000	M5 WASHER, SHAKEPROOF, SS	39
FA01561000	1/4 ZP PLAIN WASHER	39
FA01682000	M5 X 16 POZI PAN SCREW	39
FA01683000	M5 NYLOC NUT, ZP	39
FA01860000	CABLE TIE SMALL	39
FA02029000	M4 X 20 POZI PAN SCREW	38
FA02142000	M5 EXT. CER. S/PROOF 11 ZP	39
FA02431000	M4 X 8 POZI PAN, STAINLESS	38
FA03124000	M8 FULL NUT HEX ZP	39
FA03126000	M8 SPRING TYPE 'A' WASHER	39
FA03197000	M4 EXT. SHAKEPROOF WASHER	39
FA03215000	M8 STEEL FORM 'A' WASHER ZP	39
FA03227000	UNIX CLIP, 19MM	33
FA03262000	M4 SELF-LOCKING NUT, NYLOC	22, 31, 39
FA03289000	M4 NYLOC NUT, STAINLESS	38
FA04301000	M4 x .7 KNURLED THUMB NUT	30, 38
FA04320000	SPIRAL WRAP - WHITE PLASTIC	40
FA04340000	SCREW, M4 X 16 POZI PAN REC	45
FA04422000	M4 STEEL EXT SHAKE PROOF 11 M4 ZINC	20, 45
FA04431000	SCREW, M5 x 10 TAPTITE POZI PAN HEAD	23, 40
FA05206000	M3 X 16 CSK SCREW	38
FA05210000	M5 X 10 CHEESE HEAD SCREW	39
FA05643000	BLANKING PLUG 30MM	20, 40
FA07111000	M4 X 10 THUMB SCREW	38
FA07905000	BUTTON, FIR TREE, BLACK VOCE SP	6, 40

PART NUMBER - PAGE INDEX

PART #	DESCRIPTION	PAGE
FA10203000	M3 NYLOC NUT	38
FA10205000	M3 X 10 POZI PAN SCREW	38
FA10222000	PCB SUPPORT	39
FA10807000	M4 X 10 TAPTITE SCREW	38
FA10863000	M5 X 25 CARRIAGE BOLT	39
FA11188000	M4 x 35 POZI PAN SCREW	39
FA11770000	M5 NYLOC STAINLESS STEEL NUT	20
FA11774000	SELF-LOCKING NUT, M3	23
FA13304000	K40 x 10 PT SCREW LN1452	21, 22, 40
FA13304000	SCREW, K40 X 10 PT TORX - VOCE SP	15, 16
FA13305000	M5 NYLON INSERT HEX NUT	40
FA13359000	'D' TYPE SCREW LOCK SET	40
FA13683000	TWIST LOCK C/W STANDOFF	40
FA13838000	M8 x 20 CSK SKT BZP	40
FA14036000	FOOT BUCKET STOP	41
FA14699000	M4 x 25 POZI PAN REC. SCREW	40
FA14890000	SPADE CONNECTOR BOOT	39
FA14965000	GROMMET RUBBER SEMI BLIND	41
GR13141000	FACIA, COIN FLAP, STAINLESS	41
GR14978000	GLASS PRINT, VM STANDARD US BLUE SWIRL (Single KO)	4
GR14979000	GLASS PRINT, VM CARD SW BLUE SWIRL (Fully Integrated)	4
GR14981000	GLASS PRINT, 3 PAYMENT BLUE SWIRL (Double Knockout)	4
HO01139000	HOSE	36
HO03674001	SPRAY HEAD HOSE ASSY.	42
HO11253000	HOSE, EVERPURE 3/4' BSP-3	8
LO11751000	DISPENSE HEAD LOOM	26
LO13172000	LOOM ATM PCB	33
LO13496	BREWER LOOM	35
LO13653001	EVO/INF PSU LOOM - INSTANT / FB VOCE	24
LO13919000	MAINS LEAD IEC - USA	33

PART NUMBER - PAGE INDEX

PART #	DESCRIPTION	PAGE
LO14225000	LOOM GRINDER - VOCE	20, 41
LO14297000	ATM POWER LOOM - AUO	33
LO15067000	HARNESS, MEDIA DOOR LOOM	41
LO15068000	HARNESS, MEDIA ATM LOOM	41
LO15769000	LVDS LOOM	41
MA15717000	CABINET, CANISTER FILL BRACKET ASSY.	47
ME01859000	CASH BOX LOCK - VOCE SP	6
ME03024001	TEMPERATURE CUT-OUT HOLDER	33
ME03333000	KEY, CASH BOX #300245	38
ME04373000	PILE, WEATHER STRIP - GREY	45
ME10944000	MESH SCREEN for EXHAUST FAN	47
ME10944000	MESH SCREEN, 14 x 14, 0.02"	36,
ME10988000	M/F BOBBIN MOUNT M4	20, 41
ME13141000	GRAPHIC FLAP COIN	33
ME13150000	ASSY. SPRING LOCK, LOW PROFILE - VOCE SP	4, 6
ME13244000	FOOT RIGID M12 - VOCE	4
ME13463001	BELT FILTER ASSY. 1D83	27
ME1348000	COFFEE BELT - SPARE	34
ME13592001	PERISTALTIC PUMP ASSY. -24VDC	9, 15
ME13729	MOTOR ASSY., CMS MIXING SYSTEM	30
ME14043000	MIXING BOWL, SINGLE INLET - VOCE SP	30
ME14045000	CDU ASSEMBLY	28
ME14046000	ADJUSTABLE PIN ASSEMBLY	22
ME14548000	ASSY, ADAPTOR BOWL - VOCE SP	30
ME14955000	CONNECTOR 3/8" TUBE x 3/8"	42
ME14956000	ELBOW 3/8" TUBE x 3/8" STEM	42
ME15106000	OLTRE BREWER, DRIVE ROLLER, KIT	35
MO10152001	INGREDIENT MOTOR 24VDC - 125 RPM	8
MO10955000	GRINDER & MOTOR 120VAC - VOCE SP	15, 20
MO13457	CASIC - MOTOR, 24VDC, CMS MIXING SYSTEM	35

PART NUMBER - PAGE INDEX

PART #	DESCRIPTION	PAGE
MT06635	LOCK CAM, CASHBOX	48
MT10694000	BODY, DISPENSE HEAD	26
MT10695000	DISPENSE HEAD CHANNEL	26
MT10696080	FRONT COVER, DISPENSE HEAD	26
MT10697000	CODE ANGLE, DISPENSE HEAD	26
MT13077000	PLATE - I/O CIRCUIT BOARD	23
MT13078000	PSU BRACKET	24
MT13085290	PANEL, MONETARY - VOCE SP	6
MT13740000	WASTE CHUTE, OLTRE BREWER, RH	11
MT13755340	MODULE, EXTRACT TRAY, DECAF / 2 SOLUBLES	11
MT13759000	MODULE INFILL	34
MT13766000	BLANKING PLATE, WHIPPER (SMALL)	9, 11,13, 15
MT13805000	LOCK BAR - VOCE SP	6
MT13807000	SURROUND, PAINTED - VOCE SP	4
MT13826250	DISPENSE HEAD ARM	26
MT13975280	CUP STAND VOCE BLACK	34
MT14065290	BRACKET, PIVOT DRIP CATCHER - VOCE	6
MT14107290	BLANKING PLATE, DISPENSE HEAD - US	26
MT14110290	CLAMPING PLATE - DISPENSE HEAD - US	26
MT14176000	BRACKET, DOOR SWITCH ACTUATOR	6
MT14229000	PLATE, COVER MAINS LEAD	34
MT14287000	MOUNTING BRACKET, EXHAUST FAN	36
MT14465000	BLANKING PLATE, WHIPPER (LARGE)	9, 11,13, 15
MT14667000	BOILER, LID	33
MT14710340	MODULE EXTRACT TRAY - 3 SOLUBLES	13
MT14765000	CDU BRACKET	34
MT14769000	BRACKET DISPLAY	34
MT14772290	CUP CATCHER ASSY.	34
MT14777000	COVER, DOOR ROUTING BRACKET MEDIA	6
MT14792340	EXTRACT TRAY VOCE	9, 15

PART NUMBER - PAGE INDEX

PART #	DESCRIPTION	PAGE
MT14795290	MNTG. PLATE FREEVEND	35
MT14808290	VOCE CMS CDU TURRET BAND	35
MT14920290	COVER LH ATM - VOCE MEDIA	35
MT14921290	COVER RH ATM - VOCE MEDIA	35
MT15089000	ATLAS 'G' MOUNTING PLATE	6, 49
PA13590000	WASTE LEVEL PROBE	8
PA13650000	TUBING, PERISTALTIC PUMP	9, 15, 44
PH05501000	NOZZLE SET MOULDED	26
PL01172000	BUCKET, 9L, SILVER	37
PL01973000	PT PAN SCREW - M4 X 20	28, 43
PL03083000	EXTRACT HOSE ADAPTOR	36
PL04165000	'T' PIECE - 1 1/4"	36
PL06672000	BUCKET, 24L FB WASTE - GREY	37
PL10035000	RACK, MOULDING, DISPENSE HEAD	26
PL10274000	GRILL, DRIP TRAY EVO	43
PL10821000	CANISTER, LH S X 137 X 460H	12, 14
PL10856000	CANISTER, 42 x 183 x 460 - 2LB.	17
PL11170000	CANISTER 67W x 460H with AGITATOR	10, 12, 16, 17
PL11172000	CANISTER, 67W x 460H - SS AUGER, AGITATOR	10, 12, 14, 16
PL11608000	CANISTER, 67W x 760H, (NO AGITATOR)	10, 12, 14, 16, 17
PL11696000	BUNG, CANISTER	44
PL13126000	CUP CATCHER, 9oz - VOCE SP	6
PL13128000	CUP CATCHER 80mm - VOCE SP	6
PL13134000	LENS CUP SENSOR - VOCE SP	21, 22
PL13140000	COIN FLAP	44
PL13147000	CLIP, CUP CATCHER	43
PL13345000	DISPENSE HEAD MOULDING	26
PL13450000	CLEANING RIBBON (RIGHT SIDE ONLY)	35
PL13451000	RELEASE HANDLE	35
PL13452	SHAFT, GEAR MOTOR DRIVE SUPPORT CHAMBER	35

PART NUMBER - PAGE INDEX

PART #	DESCRIPTION	PAGE
PL13455	MIXING BOWL (CMS MIXING SYSTEM)	35
PL13459001	PIN with TRACTION ROLL BELT	35
PL13692000	CAROUSEL PIN TOP	28
PL13702000	CAROUSEL PLATE 306mm	28
PL13703000	CAROUSEL, 7 STACK 306mm - VOCE SP	28
PL13717000	CANISTER, RH 137D x 460H	14
PL13723000	IMPELLER	30
PL13725000	STEAM HOOD, CMS MIXING SYSTEM	30
PL13728000	SEAL, WHIPPER BOWL	30
PL13774000	TRAY, VACUUM FORMED, VEND BASE	48
PL13776000	BRACKET CUP CATCHER	43
PL13778000	BRACKET, SUREVEND - LH	22
PL13779000	BRACKET, SUREVEND RH - VOCE SP	21
PL13784000	GLASS FIXING WASHER	44
PL13802000	DRIP TRAY VOCE ROUTING	43
PL13836000	CAROUSEL, 6 STACK INSERT - VOCE SP	28
PL13839000	LID, TURRET, 7 STACK	28
PL13840002	TUBE, TURRET 7oz./8oz./9oz. - VOCE (SVR CUPS)	6, 28
PL13842002	TUBE, 12oz. TURRET, VOCE - (SVS CUPS)	6, 28
PL13843000	80mm (12oz.) CUP THROAT (not used on 5a)	28
PL13844000	CAROUSEL, 5 STACK 306mm, VOCE - SP	28
PL13873000	TUBE, 12oz. / 16oz. TURRET, VOCE - (SMR CUPS)	6, 28
PL14169000	TRANSITION CHUTE, GRINDER	20
PL14258000	HOPPER, BEAN, ROUND - 3LB.	15, 16
PL14475000	CUP REDUCING RING (70/73mm)	28, 47
PL14476000	CUP REDUCING RING (80mm)	28, 47
PL14515000	CAN S x 137 x 460 & AGITATOR & SS FRESH BREW	9
PL14515000	CANISTER S x 137 x 460 & AGITATOR & SS FRESH BREW	10
PL14578000	BEZEL BLANKING PANEL - VOCE	44
PL15118000	BLANKING PANEL, USB - VOCE	36

NOTES

Visit our Publications page on our Website under **Vending Solutions** then **Product Manuals** to find this and other manuals and technical information for the wide range of Crane Merchandising Systems products at www.cranems.com

CRANE® MERCHANDISING SYSTEMS

PARTS SUPPORT



3330 Crane Way
Williston , SC. 29853
Tel: (800) 621-7278
Fax: (803) 266-5150
Email: parts@cranems.com
Website: www.cranems.com