

Test Report Number 160-2006, Minute Maid Orange Juice 10 - oz PET
Report Dated: 5/31/2006

SUMMARY OF TEST RESULTS: Package Vend Qualification & Evaluation

Product Name: 10 oz Minute Maid Orange Juice
 Manufactured By: Coke
 Bottle: 10 oz PET
 Size: Length 5.85", Top OD 2.54", Bottom OD 2.54"

Tested at SandenVendo America, Inc.- Dallas, TX
 Test location: Engineering Test Lab
 Test Verified BY: Tony Motlagh - Engineering Test Lab

Vending Machine set up	Uni-2 (79.5)	V-Max (840)	V-21 (821)	GFV (VUE 40)
Product Depth/Cam Setting	3	3		N/A
Back Spacer	12	15		N/A
Magnatic Spacer	N/A	N/A		N/A
Neck Guide	N/A	N/A		N/A
Lower Partition Clip	P/Ns C1 (1066112-1) & E0 (1121704)	P/Ns B1 (1066104) & E0 (1121704)		N/A
Side Shim Type	P/N - 1060686	P/N - 1078864		N/A
Gage Bar Position	2	2		N/A
Test Column Quantity	10	10		9 per shelves
Ambient Temperature	75	74		73
Package Temperature	36	37		36
Humidity	44	46		44
Max Prod can be Stacked in Col	57	66		360
Orientation in Column	Cap to Butt	Cap to Butt		N/A
Total Product Vend	10,000	10,000		2,000
Test Results	All Passed	All Passed		All Passed

NOTES	1 & 2	1 & 2		1 & 2
-------	-------	-------	--	-------

Note 1: All the vending machine moving parts and assemblies must be cleaned at all time to prevent failures

Note 2: All the vending machine worn parts and components must be replaced to prevent failures

Vendo[®] Engineering Uni-2 Set Up Guide

Size: 12oz / 355ml
 Pkg. Description/Type: 12oz / 355ml POWERADE PET
 Franchise: COKE

Rev. A Date 7/31/01

KIT#

Column Setup

Cam Setting	Back Spacer	Neck Guide Locations	Gage Bar Clip Location	Gage Bar Location	Side Spacer	Sold Out Flap	Sold Out Spacer
3	13	N/A	B/#1, B/#2	#2	1060686 Loc. #2	Short* 1083449	1077457

Note: To properly vend product the Uni-2 must have the columns set up as illustrated. *Spring Loc. Rt (Low Tension) side.

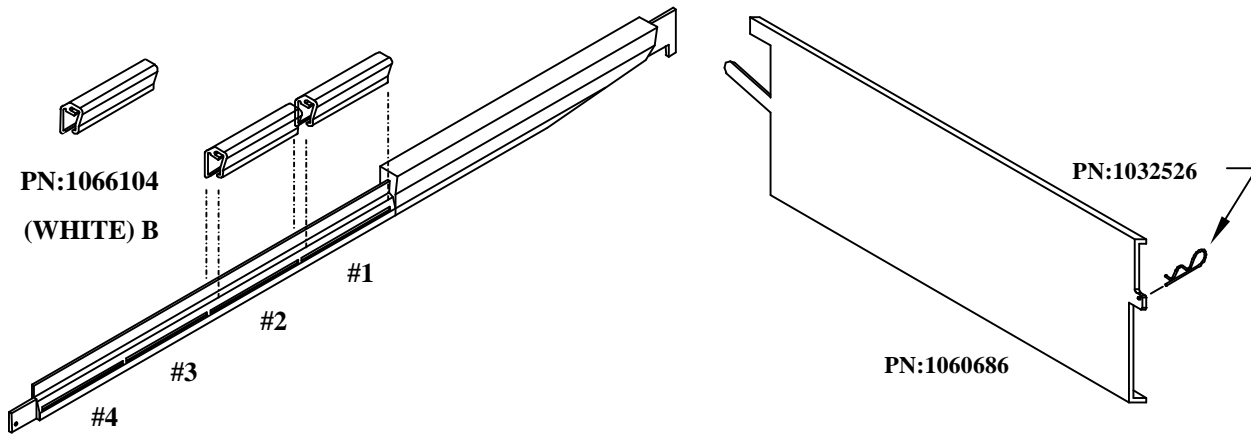

Gage Bar Clip Location

Shim/Spacer

Set Up Guide

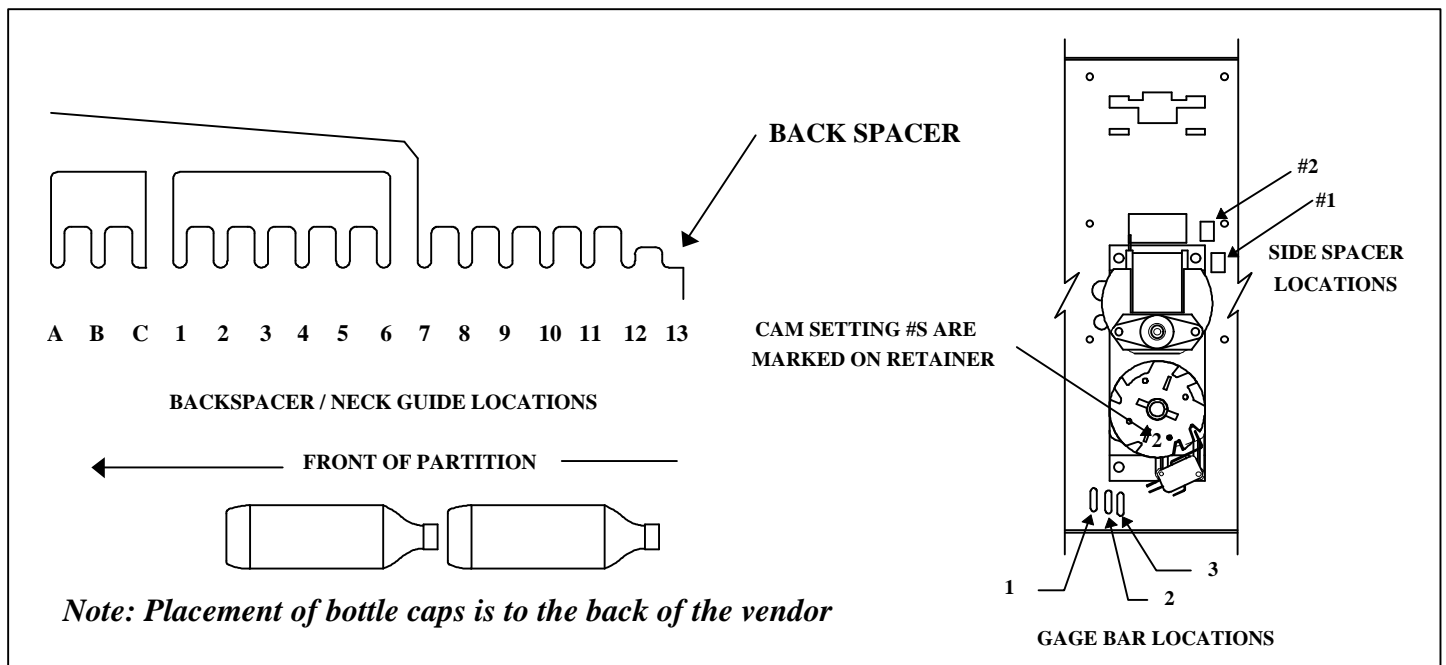

FOR OTHER PRODUCT SET-UP GUIDES, CONTACT THE VENDO COMPANY
 TEL: (559) 439-1770 FAX: (559) 650-3455.

Installation Instruction #

Vendo[®] Engineering 511 Uni-2 Set Up Guide

Size: 12oz / 355ml

Rev. A Date 6/14/00

Pkg. Description/Type: DASANI

Franchise: COKE

KIT#1121858

Column Setup

Cam Setting	Back Spacer	Neck Guide Locations	Gage Bar Clip Location	Gage Bar Location	Side Spacer	Magnetic Column Spacer (*)	Sold Out Flap	Sold Out Spacer
2	6	N/A	C/#1	#2	1060686 Loc. #2	TWO 1121822-3	Short 1083449	1077457

Note: To properly vend product the Uni-2 must have the columns set up as illustrated.

*Install magnetic column spacers into right side of partition above product side spacer (See Figure 1 for installation detail)

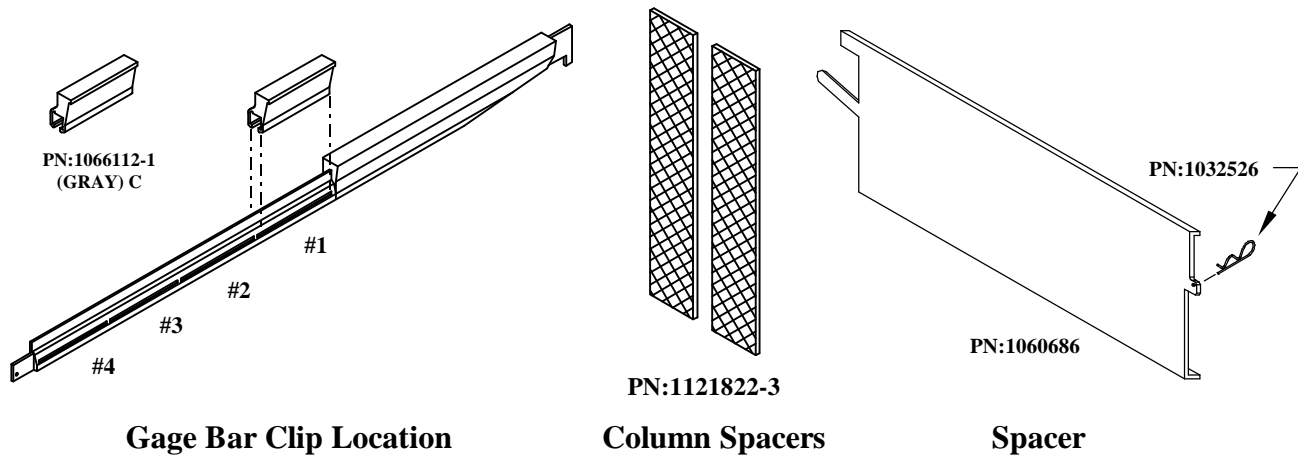

Set Up Guide

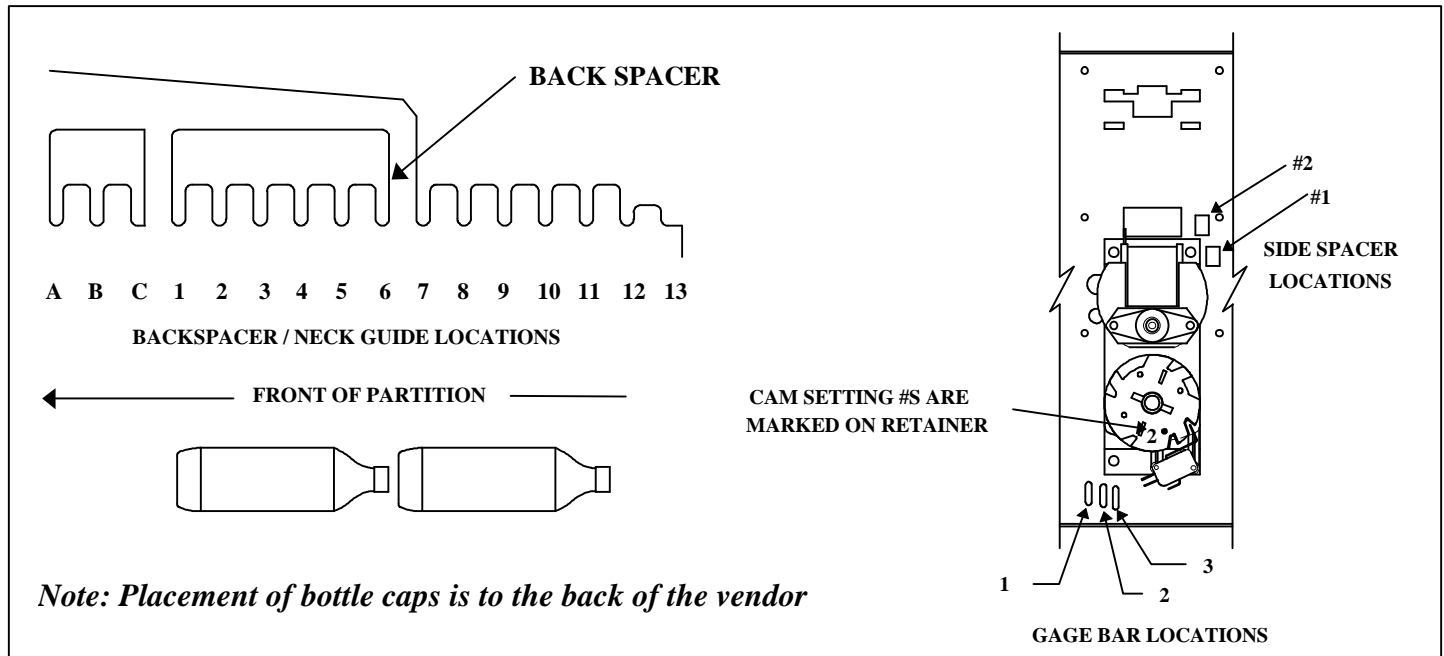

FOR OTHER PRODUCT SET-UP GUIDES, CONTACT THE VENDO COMPANY.

TEL: (559) 439-1770 FAX: (559) 439-2083.

Installation Instruction #1121868

Caution: Disconnect power cord from power source before beginning installation

Installation (see Figure 1)

Step #1 Locate Back Spacer into position #6.

Step #2 Install .37 product side spacer (P/N1060686).

Step #3 Install two of the 33" long magnetic foam pads (P/N1121822-3) on the right side partition.

Locate pads as shown in Figure 1 above the .37 product side spacer (P/N1060686)

P/N1060686

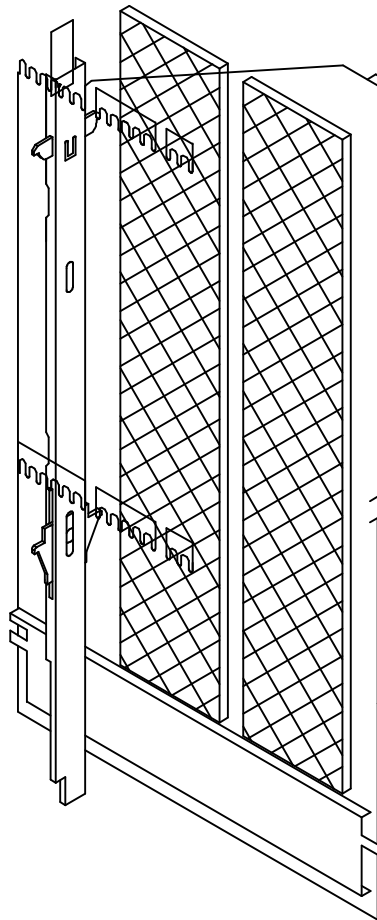

P/N 1121822-3
2 places

Figure 1
Right Side Partition

Vendo[®] Engineering 601 Uni-2 Set Up Guide

Size: 12oz / 355ml

Rev. A Date 6/14/00

Pkg. Description/Type: DASANI

Franchise: COKE

KIT#1121859

Column Setup

Cam Setting	Back Spacer	Neck Guide Locations	Gage Bar Clip Location	Gage Bar Location	Side Spacer	Magnetic Column Spacer (*)	Sold Out Flap	Sold Out Spacer
2	6	N/A	C/#1	#2	1060686 Loc. #2	TWO 1121822-2	Short 1083449	1077457

Note: To properly vend product the Uni-2 must have the columns set up as illustrated.

*Install magnetic column spacers into right side of partition above product side spacer (See Figure 1 for installation detail)

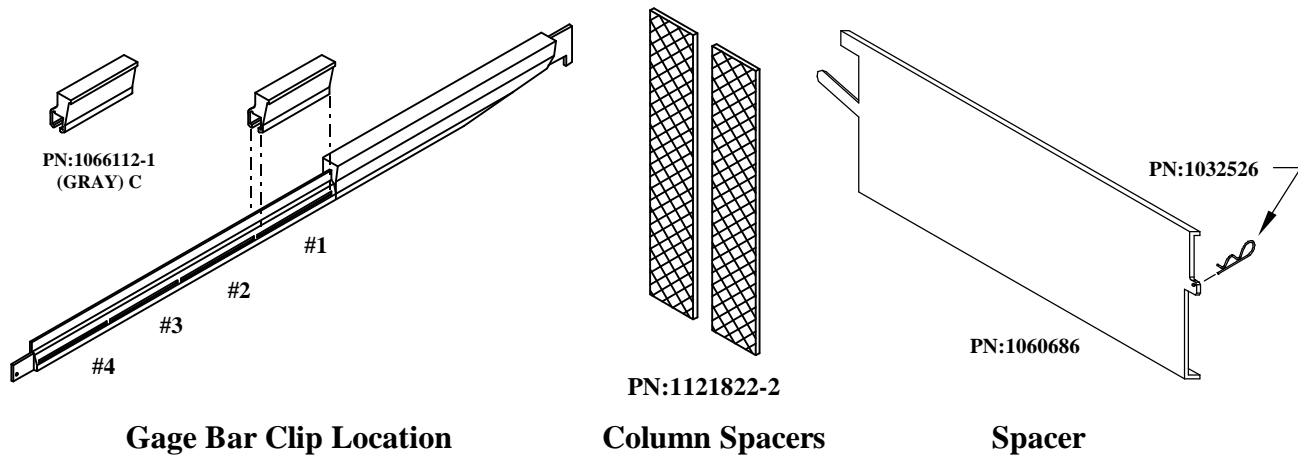

Set Up Guide

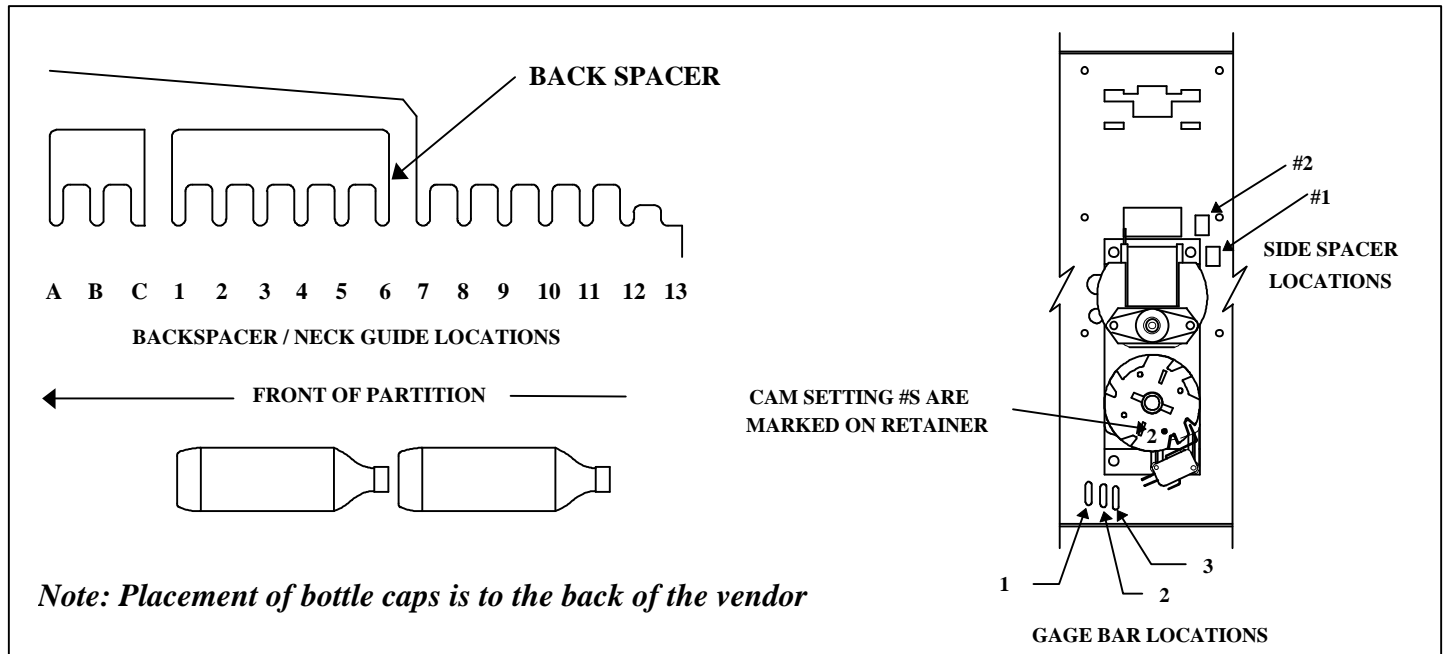

FOR OTHER PRODUCT SET-UP GUIDES, CONTACT THE VENDO COMPANY.

TEL: (559) 439-1770 FAX: (559) 439-2083.

Installation Instruction #1121869

Caution: Disconnect power cord from power source before beginning installation

Installation (see Figure 1)

Step #1 Locate Back Spacer into position #6.

Step #2 Install .37 product side spacer (P/N1060686).

Step #3 Install two of the 38" long magnetic foam pads (P/N1121822-3) on the right side partition.

Locate pads as shown in Figure 1 above the .37 product side spacer (P/N1060686)

P/N1060686

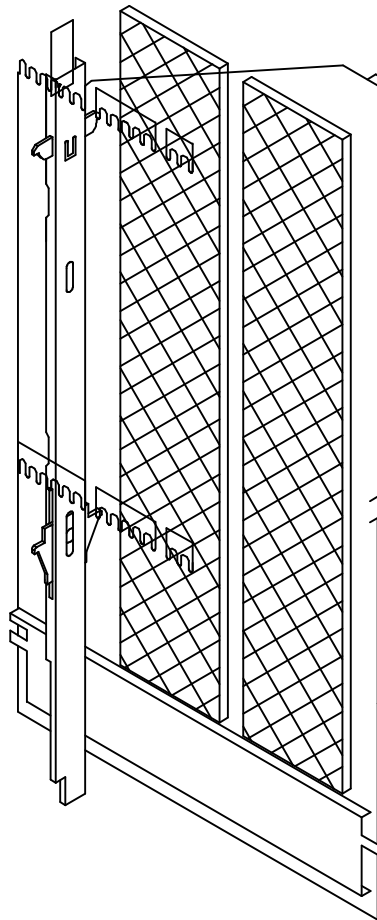

P/N 1121822-2
2 places

Figure 1
Right Side Partition

2/10/96

1. PRODUCT

12 OZ. CANS - 2.60 x 4.84 Long

2. PRODUCT CAPACITY

48 PER COLUMN - 72", 57 PER COLUMN - 79"

3. SET UP GUIDE UNIVENDOR-2

Product	CAM POSITION	BACK SPACER	GAGE BAR	Sold out Lever	SIDE SPACER	GAGE BAR CLIP	
						Part No.	Position
12 oz CANS	3	8	2	389242 SHORT	1060686	1066104 White	1 & 2

Note: To properly vend 12 oz. Cans. The Univendor-2 must have the columns setup correctly.

4. GAGE BAR CLIP SET UP.

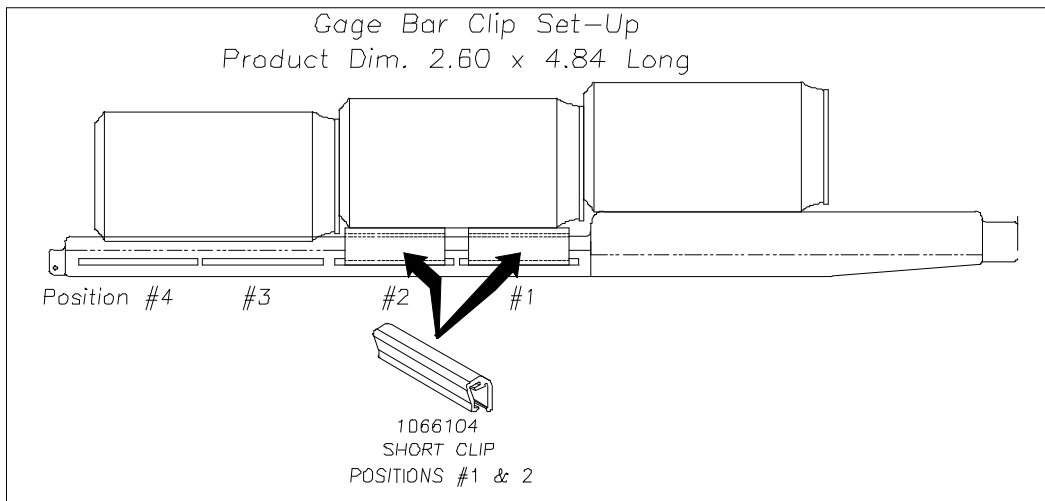

5. SET UP GUIDE.

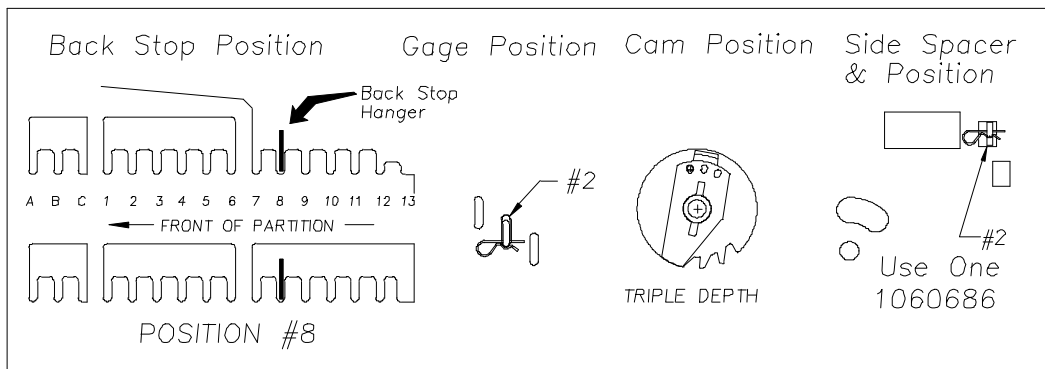

6. SOLD-OUT LEVER TO BE SHORT STYLE WITH FRONT SPACER. SPRING TO BE LOCATED ON THE RIGHT SIDE (LOW PRESSURE SETTING).

12 OZ. 355ml CANS



UNIVENDOR-2 PRODUCT SET-UP GUIDE

5/5/97

1. PRODUCT

2.60 x 5.15 Coke Contour Can Drink

2. PRODUCT CAPACITY

48 PER COLUMN - 72", 57 PER COLUMN - 79"

3. SET UP GUIDE

CAM POSITION	BACK SPACER	GAGE BAR	Sold out Lever	SIDE SPACER	GAGE BAR CLIP	
					Part No.	Position
3	9	2	389242 SHORT	1060686	1066104	1 & 2

4. GAGE BAR CLIP SET UP.

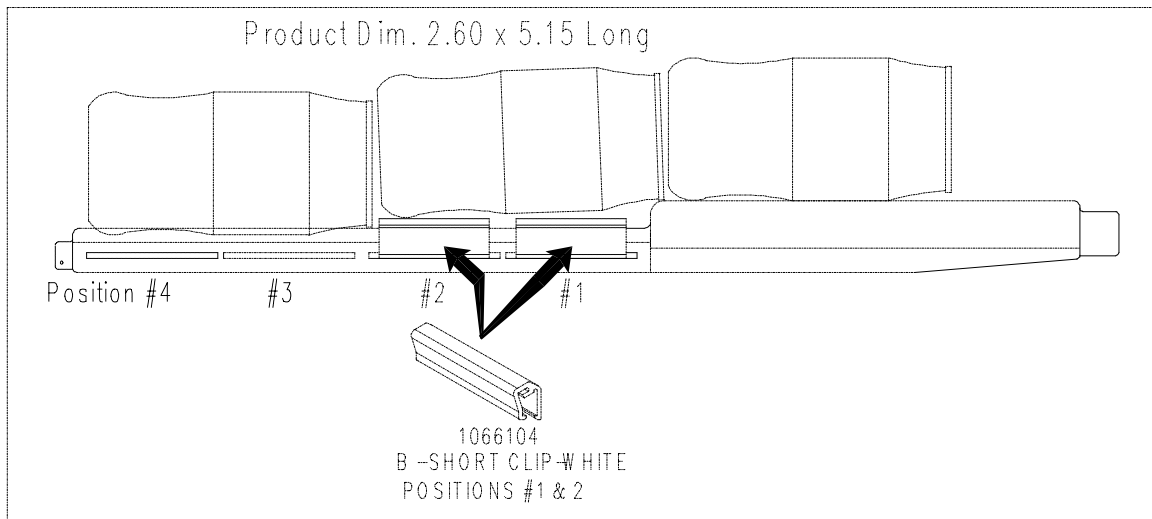

5. SET UP GUIDE.

Back Spacer Position	Gage Bar Position	Cam Position	Side Shim & Position

6. SOLD-OUT LEVER TO BE SHORT STYLE WITH FRONT SPACER.

SPRING TO BE LOCATED ON THE RIGHT SIDE (LOW PRESSURE SETTING).

7. FOR OTHER PRODUCT SET-UP GUIDES, CONTACT THE VENDO COMPANY.

TEL: (209)439-1770 FAX: (209) 439-2083.

Vendo[®] Engineering *Uni-2 Set Up Guide*

Size: 15.2oz/450 ml

Rev. A Date 3/26/03

Pkg. Description/Type: MINUTE MAID PET

Franchise: COKE

Column Setup

Cam Setting	Back Spacer	Neck Guide Locations	Gage Bar Clip Location	Gage Bar Location	Side Spacer	Sold Out Flap	Sold Out Spacer
2	9	N/A	C/#1	#1	1073589 Loc. #2	Short 1083449	1077457

Note: To properly vend product the Uni-2 must have the columns set up as illustrated. *Spring Loc. Rt (Low Tension) side.

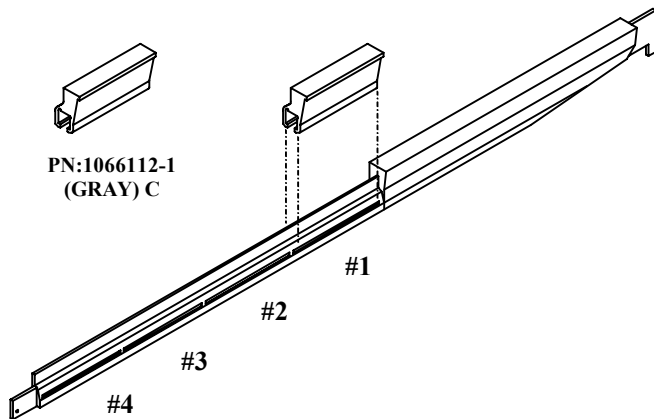

Gage Bar Clip Location

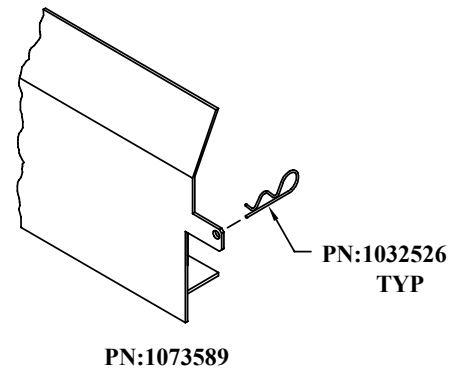

Shim/Spacer

Set Up Guide

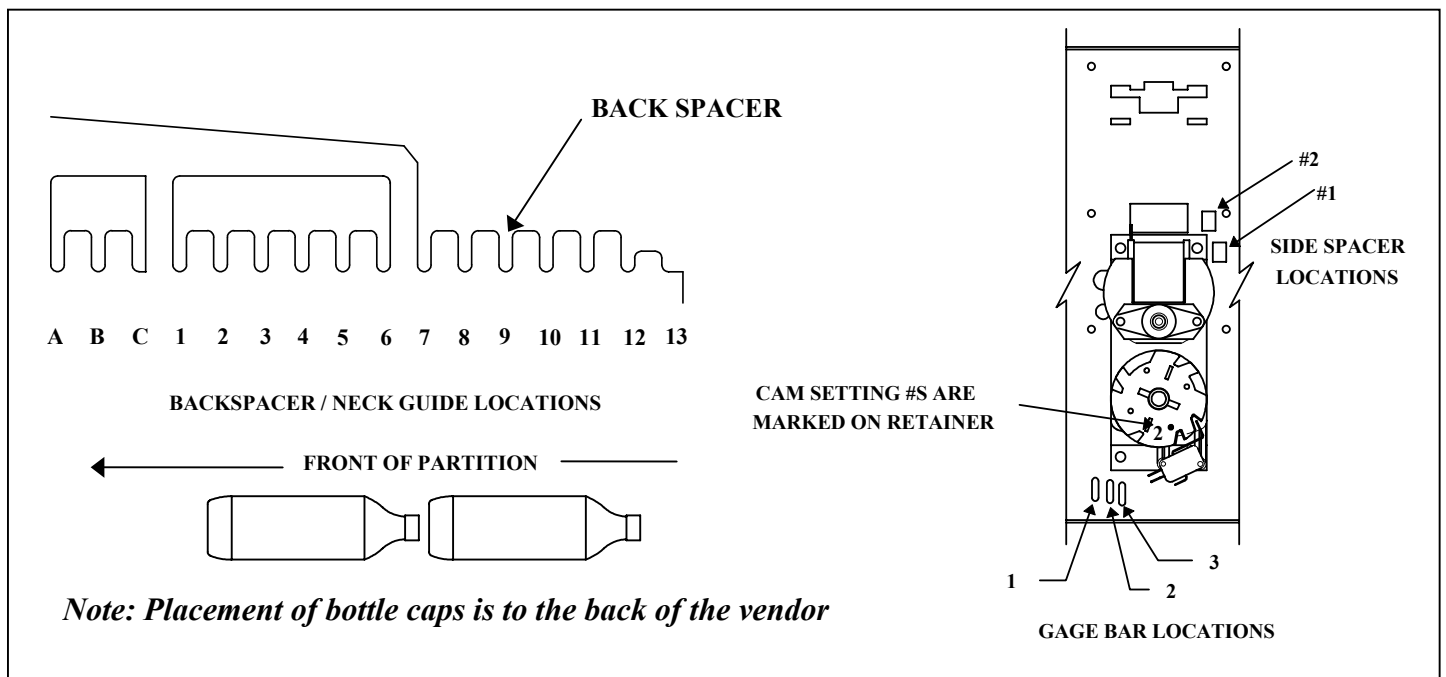

FOR OTHER PRODUCT SET-UP GUIDES, CONTACT THE VENDO COMPANY.

TEL: (559) 439-1770 FAX: (559) 650-3455.

1. PRODUCT

16 OZ. MINUTE MAID PET - 2.84 - 2.92f x 6.78L Long

2. PRODUCT CAPACITY

28 PER COLUMN - 72", 34 PER COLUMN - 79"

3. SET UP GUIDE UNIVENDOR-2

Product	CAM POSITION	BACK SPACER	GAGE BAR	Sold out Lever	Spacer	SIDE SHIM	GAGE BAR CLIP	
							Part No.	Position
16 oz M. Maid	2	6	1	1083449	1077457	NA	1066112-1 1066104	1 2

Note: To properly vend 16oz. Minute Maid. The Univendor-2 must have the columns setup correctly.

4. GAGE BAR CLIP SET UP.

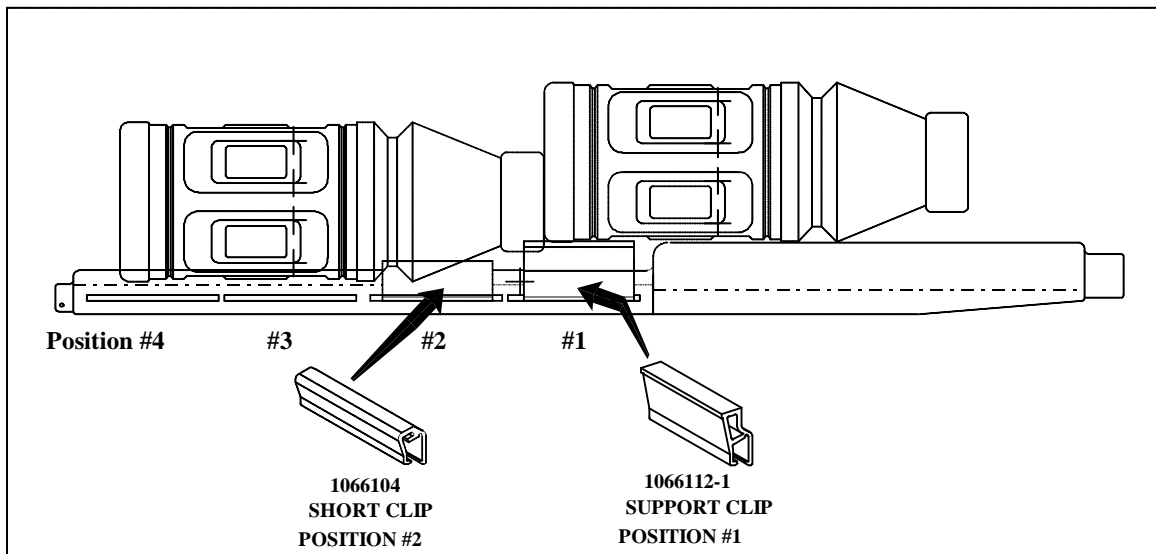

5. SET UP GUIDE.

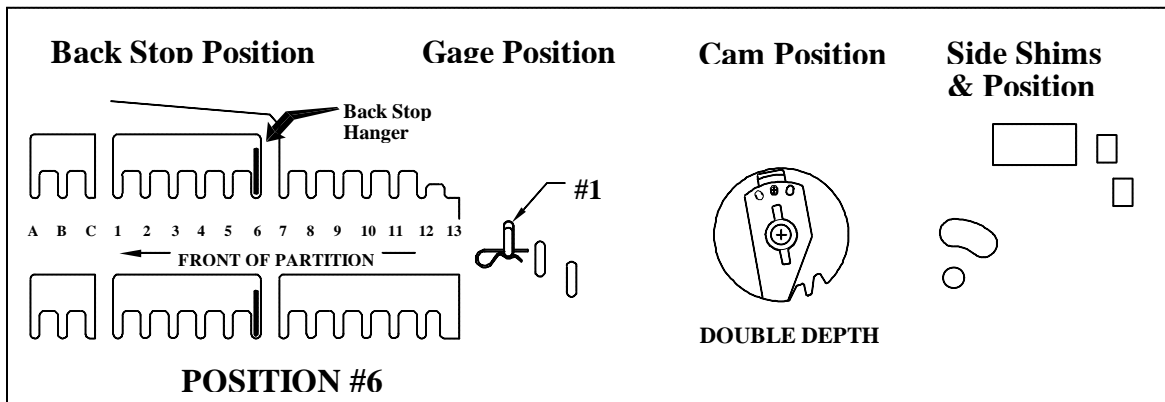

**6. SOLD-OUT LEVER TO BE SHORT STYLE WITH FRONT SPACER.
SPRING TO BE LOCATED ON THE RIGHT SIDE (LOW PRESSURE SETTING).**

**7. FOR OTHER PRODUCT SET UP GUIDES CONTACT THE VENDO COMPANY.
TEL: (559) 439-1770 FAX: (559) 439-2083.**

1. PRODUCT

16 OZ. NESTEA PET - 2.84 - 2.92f x 6.78L Long

2. PRODUCT CAPACITY

28 PER COLUMN - 72", 34 PER COLUMN - 79"

3. SET UP GUIDE UNIVENDOR-2

Product	CAM POSITION	BACK SPACER	GAGE BAR	Sold out Lever	Spacer	SIDE SHIM	GAGE BAR CLIP	
						Part No.	Position	
16 oz Nestea	2	6	1	1083449	1077457	NA	1066112-1	1
							1066104	2

Note: To properly vend 16oz. Nestea. The Univendor-2 must have the columns setup correctly.

4. GAGE BAR CLIP SET UP.

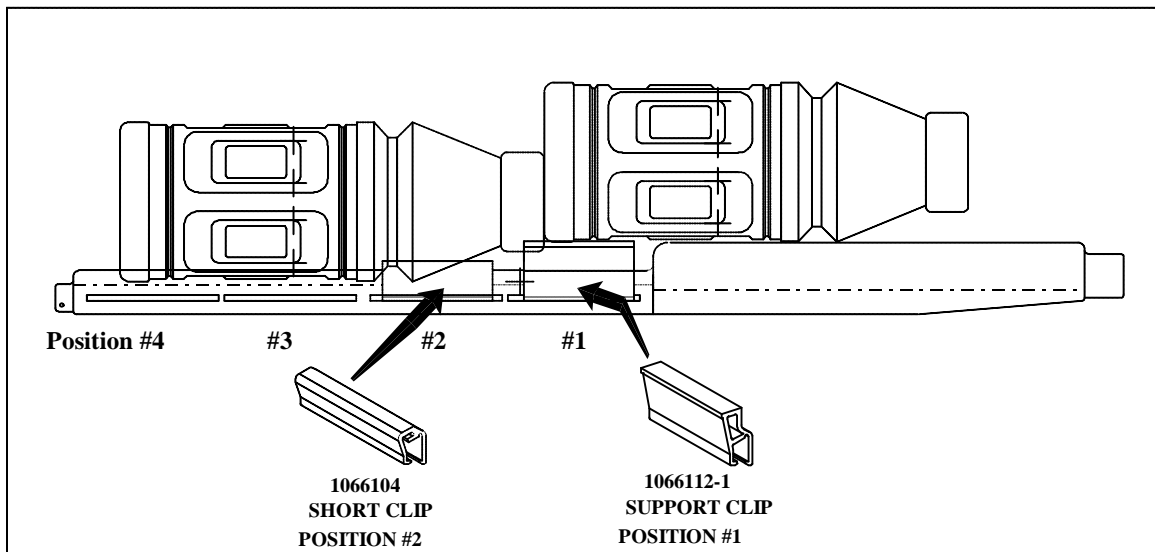

5. SET UP GUIDE.

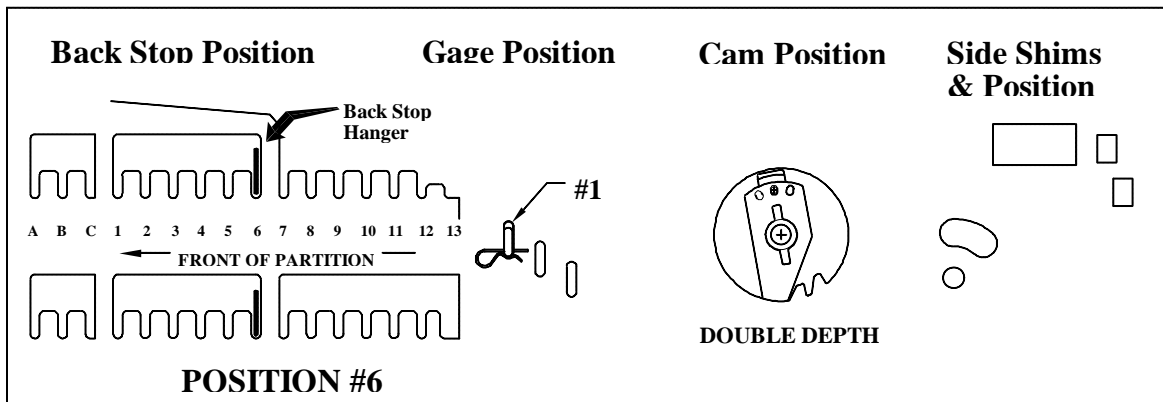

6. SOLD-OUT LEVER TO BE SHORT STYLE WITH FRONT SPACER.
SPRING TO BE LOCATED ON THE RIGHT SIDE (LOW PRESSURE SETTING).

7. FOR OTHER PRODUCT SET UP GUIDES CONTACT THE VENDO COMPANY.
TEL: (559) 439-1770 FAX: (559) 439-2083.

Vendo[®] Engineering Uni-2 Set Up Guide

Size: 17.6oz/520ml

Rev. A Date 3/31/03

Pkg. Description/Type: Mad River

Franchise: Coca-Cola

Column Setup

Cam Setting	Back Spacer	Neck Guide Locations	Gage Bar Clip Location	Gage Bar Location	Side Spacer	Sold Out Flap	Sold Out Spacer
2	10	N/A	C/#1, E/#5	#1	3 -1074465 Loc. #1	Short* 1083449	1077457

Note: To properly vend product, the Uni-2 must have the columns set up as illustrated. *Spring Loc. Rt (Low Tension) side.

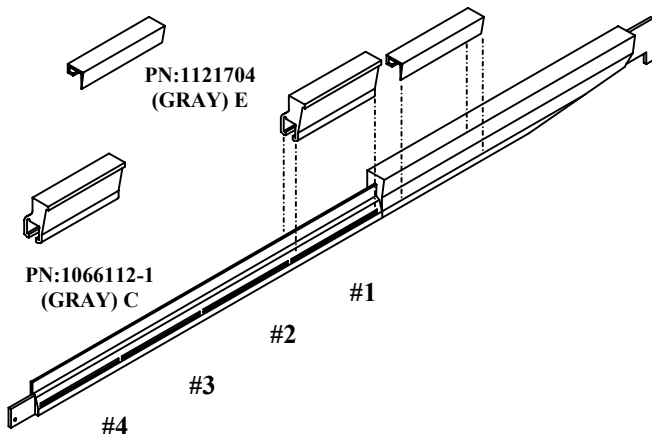

Gage Bar Clip Location

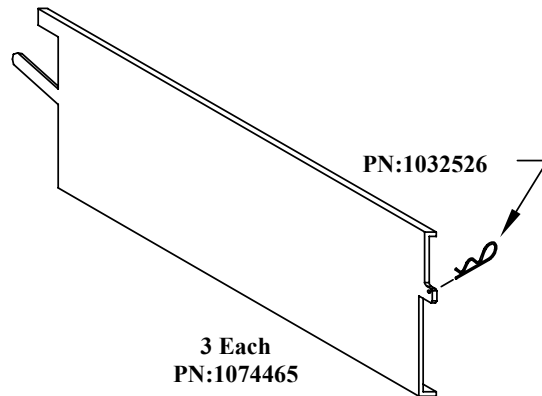

Shim/Spacer

Set Up Guide

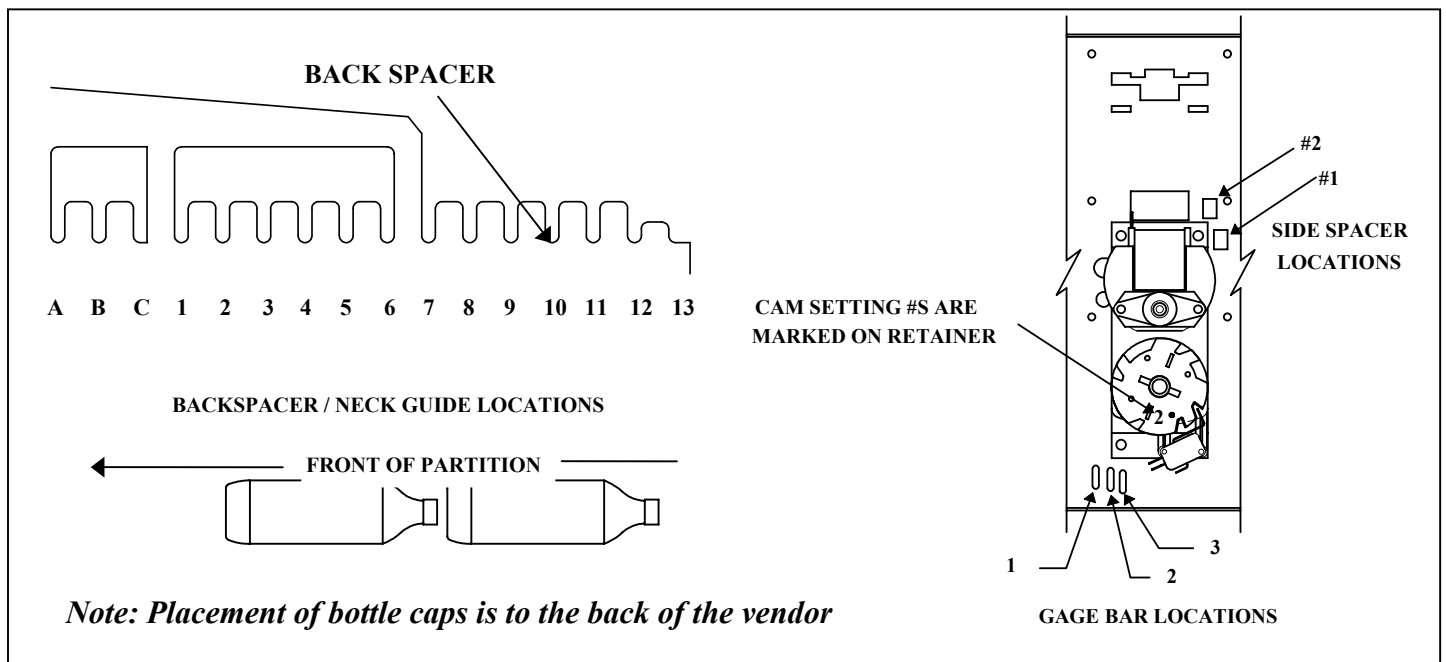

Note: Placement of bottle caps is to the back of the vendor

FOR OTHER PRODUCT SET-UP GUIDES, CONTACT THE VENDO COMPANY
 TEL: (559) 439-1770 FAX: (559) 439-2083.

1. PRODUCT

20 OZ. COKE CONTOUR - 2.86 x 8.94 Long

2. PRODUCT CAPACITY

28 PER COLUMN - 72", 34 PER COLUMN - 79"

3. SET UP GUIDE UNIVENDOR-2

Product	CAM POSITION	BACK SPACER	GAGE BAR	Sold out Lever	SIDE SHIM	GAGE BAR CLIP	
						Part No.	Position
20 oz COKE	2	13	1	389242 SHORT	NONE	1066112	1

Note: To properly vend 20 oz.Coke. The Univendor-2 must have the columns setup correctly.

4. GAGE BAR CLIP SET UP.

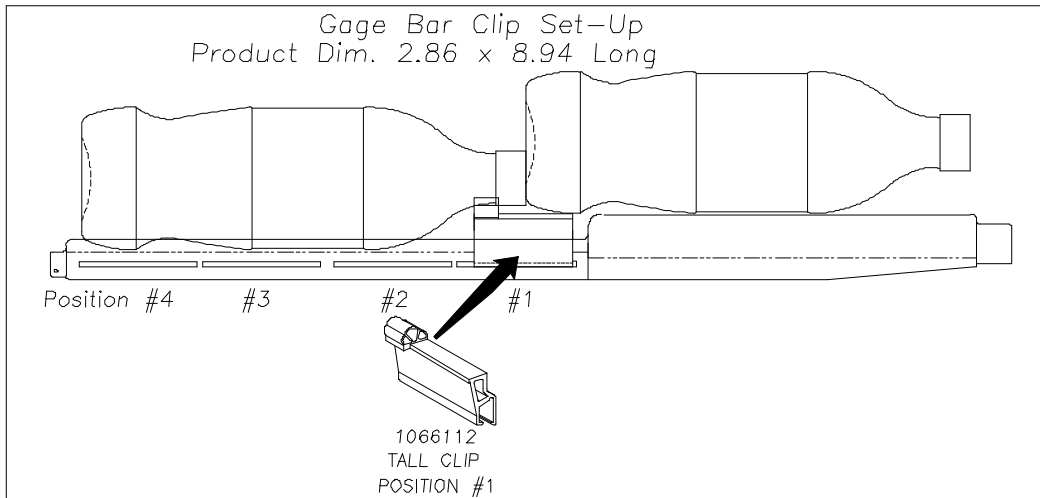

5. SET UP GUIDE.

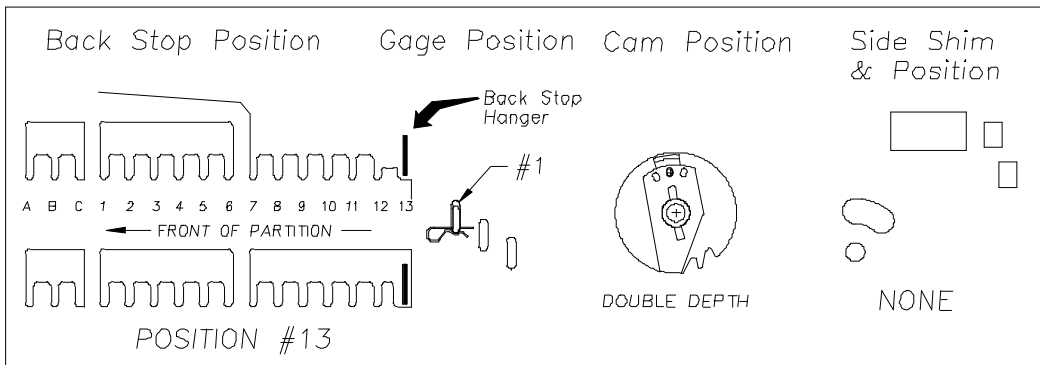

**6. SOLD-OUT LEVER TO BE SHORT STYLE WITH FRONT SPACER.
SPRING TO BE LOCATED ON THE RIGHT SIDE (LOW PRESSURE SETTING).**

Test Report Number 150-2006, DASANI Water 20 oz PET
Report Dated: 3/6/2006

SUMMARY OF TEST RESULTS: Package Vend Qualification & Evaluation

Product Name: DASANI Water
 Manufactured By: Pepsi
 Bottle: 20 oz PET
 Size: Length 9.00", Top OD 2.83", Bottom OD 2.86"

Tested at SandenVendo America, Inc.- Dallas, TX
 Test location: Engineering Test Lab
 Test Verified BY: Tony Motlagh - Engineering Test Lab

Vending Machine set up	Uni-2 (79.5)	V-Max (840)	GFV (VUE 40)
Product Depth/Cam Setting	2	2	N/A
Back Spacer	13	13	N/A
Neck Guide	N/A	16	N/A
Lower Partition Clip	P/N C1-1066112-1	A1 (1066112)	N/A
Side Shim Type	P/N -1074465	N/A	N/A
Gage Bar Position	1	1	N/A
Test Column Quantity	10	10	8 per shelf
Ambient Temperature	75	74	74
Package Temperature	37	37	37
Humidity	46	46	44
Max Prod can Stacked in Col	38	38	320
Orientation in Column	Cap to Butt	Cap to Butt	N/A
Total Product Vend	10,000	10,000	2,000
Test Results	All Passed	All Passed	All Passed
NOTES	1 & 2	1 & 2	1 & 2

Note 1: All the moving parts and assemblies must be cleaned at all time to prevent failures

Note 2: All the worn parts and components must be replaced to prevent failures

Recommendation and Observations:

Package is well designed for vending in Uni2 and Vmax

1. PRODUCT

20 Oz. COKE CONTOUR PET- 2.83 x over 9.00" Long

2. PRODUCT CAPACITY

28 PER COLUMN - 72", 34 PER COLUMN - 79"

3. SET UP GUIDE UNIVENDOR-2

Product	CAM POSITION	BACK SPACER	GAGE BAR	Sold out Lever	SIDE SHIM	GAGE BAR CLIP		BUCKET KIT #
						Part No.	Position	
20 Oz. Coke	2	11	1	389242 SHORT	NONE	1066112	1	1073775M 10 Columns

Note: To properly vend 20oz. PET Coke. The Univendor-2 must have the columns setup as illustrated.

4. GAGE BAR CLIP SET UP.

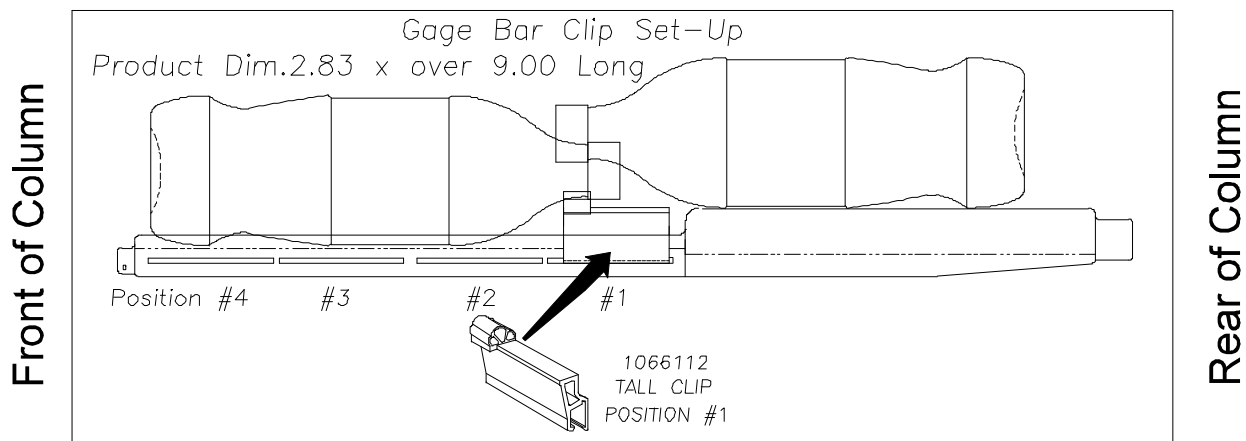

Note: Gage bar clip functioning as anti-theft device and therefore must be installed.

5. SET UP GUIDE.

Column Load See Note # 8	Back Spacer Position	Gage Bar Position	Cam Position	Side Shim & Position

6. BUCKET SET- UP: (requires kit #1085589) install foam tape into buckets per installation instructions included in kit.

7. SOLD-OUT LEVER TO BE SHORT STYLE WITH FRONT SPACER : Spring to be located on the right side (low pressure setting).

8. The bottles **MUST** be loaded as follows to avoid jams:

Arrange bottle caps so that the cap of the **FRONT BOTTLE** of each layer of 2 bottles (front & rear) is on **TOP** of the rear bottle-cap in that layer. For easiest loading, place rear bottle first, followed by front, then alternating rear & front until column is full, being careful to maintain the prescribed pattern.

Instrument Used for Relative Humidity validation: EXTECH Thermometer/RH Meter S/N M 16423

Temp Pkg: 38.3 ° F (must be btw 32-40° F) Amb. Temp: 76.0 ° F R. H. 45.0 % Page 1 of 1

Type of test req: Class A (10k vend) Class B (5k vend) Class C (2k vend) Prototype Test
 Column Setup Extensive Test Moderate Test Minimum Test New product tryout

Product Depth	Back Spacer	Gage Bar Clip Location	Gage Bar Location	Product Orientation	Side Shim-Spacer	Sold Out Flap	Magnetic Column Spacer	Column Quantity	Sold Out Spacer
2	11	A #1	#1	Cap to Butt	P/N 1074465 x 2	Short P/N 1083449	N/A	34	P/N 1077457

Test Report written by : Walter Ristic

TEST performed by: Art Robinson

Product was loaded with "Cap to Butt" configuration!

Vend Qty.=30 Accumulated vends:10200

Vend Load #	Col. #	#Prod Load above Gate	Fault Cat.	Class Fault A,B,C	
9	4	36	A	Gate Pass	
9	7	36	A	Gate Pass	RPPM = {12*1,000,000} / 10200 = 1176 PPM (jams per million vends)
1	4	34	A	Gate Pass	
11	7	30	A	Gate Pass	Results are in "Vendo" tolerance 200<RPP<1200 M for moderate vending
11	2	34	A	Gate Pass	
11	4	20	A	Gate Pass	
12	7	34	A	Gate Pass	NOTE: After consecutibve gate passes, in columns #4 & #7 motors have been changed and gage bars (no problem, after);
12	4	34	A	Gate Pass	
13	7	34	A	Gate Pass	
13	4	22	A	Gate Pass	
15	7	34	A	Gate Pass	
16	8	30	A	Gate Pass	

Conclusion: Product is moderately vendable in our machine (it will vend with average 1 jam per 3 loads)

PPM=0 Excellent Vending

0<PPM < or =200 Very Good Vending

200<PPM< or = 1200 Moderate Vending

1200<PPM< or = 2860 Acceptable Vending

2860<PPM< and up ; NOT ACCEPTABLE VENDING

Position and Location of Product (Sketch)



Carbonater
 Class A Te
 Class B Te
 Class C Te

ndor. Note: **One refresh** (replacement) of product is required at **5,000 vends**.
 ndor Note: No refresh (replacement) of product is required.
 ndor Note: No refresh (replacement) of product is required.

Non-Carbo.....

Class A Testing Extensive Test 10,000 total vends on vendor.

Note: Two refresh (replacement) of product is required at 3,333 & 6,666 vends.

Class B Testing Moderate Test 5,000 total vends on vendor Note: **One refresh** (replacement) of product is required at **2,500 vends**.

Class C Testing Minimum Test 2,000 total vends on vendor Note: No refresh (replacement) of product is required

Prototype Testing Engineering to specify number of vends

See Engineering Test Lab for Fault Category

1. PRODUCT

20 OZ. COKE SPRITE CONTOUR - 2.83 Top x 2.88 Btm x 8.95 Long

2. PRODUCT CAPACITY

28 PER COLUMN - 72", 34 PER COLUMN - 79"

3. SET UP GUIDE UNIVENDOR-2

Product	CAM POSITION	BACK SPACER	GAGE BAR	Sold out Lever	SIDE	GAGE BAR CLIP	
					SHIM	Part No.	Position
20 oz CokeSprite	2	13	1	389242 SHORT	NONE	1066112	1

Note: To properly vend 20oz. Sprite. The Univendor-2 must have the columns setup correctly.

4. GAGE BAR CLIP SET UP.

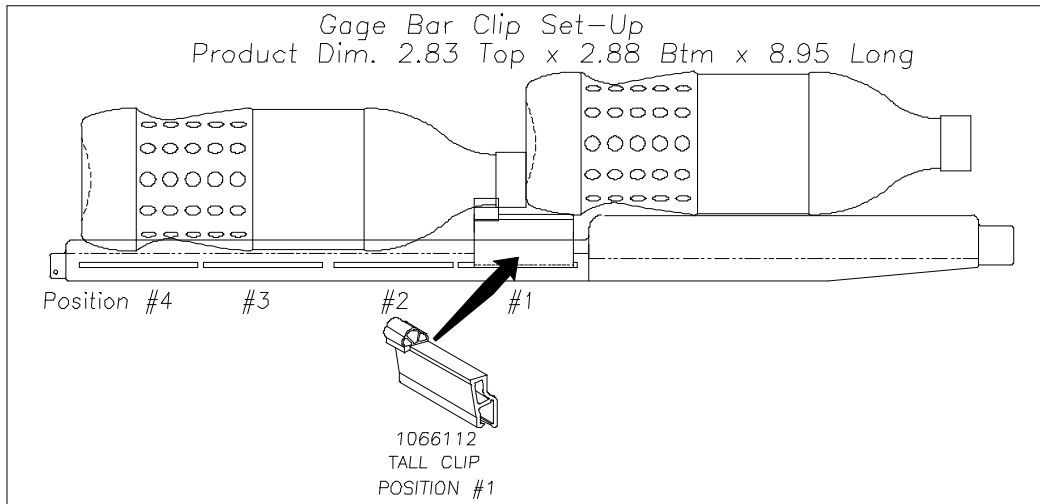

5. SET UP GUIDE.

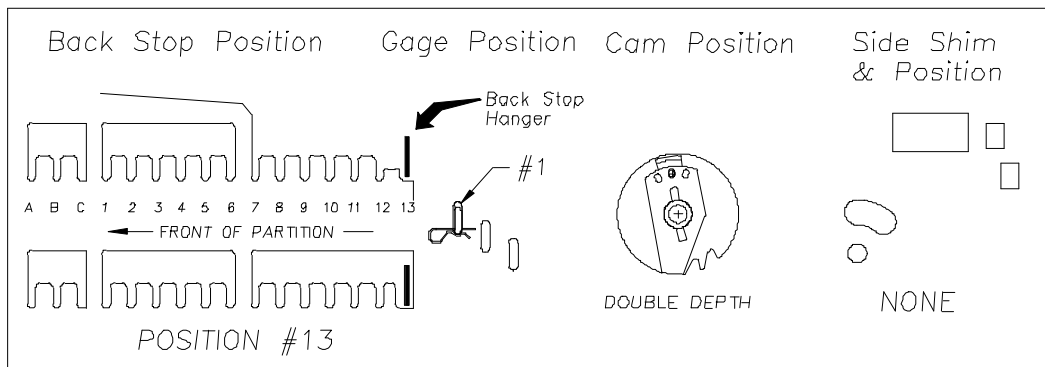

**6. SOLD-OUT LEVER TO BE SHORT STYLE WITH FRONT SPACER.
SPRING TO BE LOCATED ON THE RIGHT SIDE (LOW PRESSURE SETTING).**

1. PRODUCT

20 OZ. BOLT COKE CONTOUR - 2.88 top x 2.87 btm x 9.00 Long

2. PRODUCT CAPACITY

28 PER COLUMN - 72", 34 PER COLUMN - 79"

3. SET UP GUIDE UNIVENDOR-2

Product	CAM POSITION	BACK SPACER	GAGE BAR	Sold out Lever	SIDE SHIM	GAGE BAR CLIP	
						Part No.	Position
20 oz BOLT	2	13	1	389242 SHORT	NONE	1066112	1

Note: To properly vend 20 oz.Bolt. The Univendor-2 must have the columns setup correctly. Kit # 1077457, longer sold out block will be needed.

4. GAGE BAR CLIP SET UP.

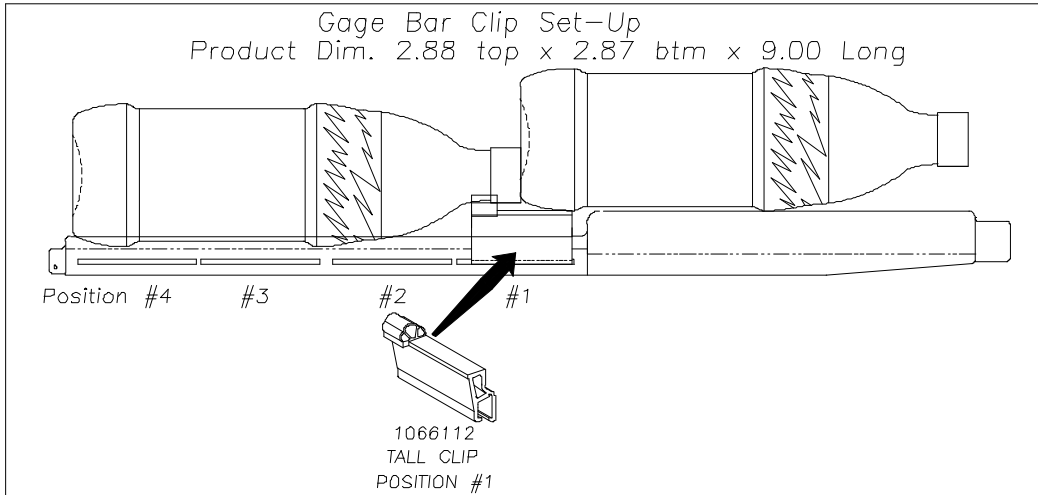

5. SET UP GUIDE.

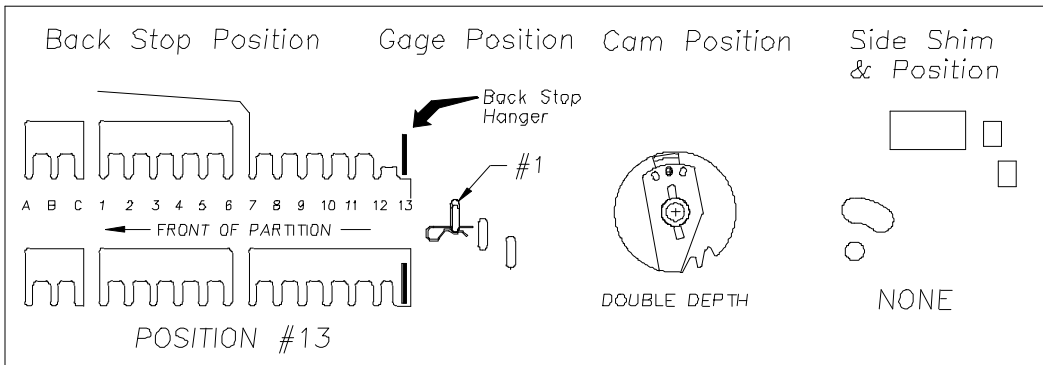

6. SOLD-OUT LEVER TO BE SHORT STYLE WITH FRONT SPACER PN 1077457. SPRING TO BE LOCATED ON THE RIGHT SIDE (LOW PRESSURE SETTING).

20 oz Vault Bottle

Setup Instructions for Vendo Vending Machines



Vender Models	Column Type	Loading Info.	Parts Needed for <u>Each</u> Column				Steps to complete for <u>Each</u> Column	
			?	#	Part Description	Part Number	?	
V-Max V-840 V-800 V-630 V-603 V-540 V-720	Narrow	Caps to Rear Double Depth		1 1 1	Gage Bar Clip A Short Sold Out Flap Sold Out Spacer	1066112 1083449 1077457		1. Install gage bar clip A: Position # 1 2. Gage bar location: 1 3. Adjust rear spacer: hole # 17
V-21	Narrow	Caps to Rear Double Depth						1. Adjust rear spacer: 10 2. Lower partition clip: Back
Uni II	Narrow	Caps to Rear Single Depth		1 1 1	Gage Bar Clip A Short Sold Out Flap Sold Out Spacer	1066112 1083449 1077457		1. Install gage bar clip A: Position # 1 2. Gage bar location: 1 3. Adjust rear spacer: C
GFV	Shelves	Package Upright			N/A	N/A		N/A

NOTES:

- For technical assistance, contact The Vendo Company at 1-800-344-7216 or www.vendoco.com.

1. PRODUCT

500 ML, 1 PT.9 OZ. NAYA CANADIAN WATER PET BOTTLE - 2.41 Top x 2.43 Btm x 8.68 Long

2. PRODUCT CAPACITY

34 PER COLUMN - 72", 42 PER COLUMN - 79"

3. SET UP GUIDE UNIVENDOR-2

Product	CAM POSITION	BACK SPACER	GAGE BAR	Sold out Lever	SIDE SPACER	GAGE BAR CLIP	
						Part No.	Position
500 ML NAYA	2	13	3	389242 SHORT	1069791	NONE	0

Note: To properly vend 500ML. NAYA. The Univendor-2 must have the columns setup correctly.

4. GAGE BAR CLIP SET UP.

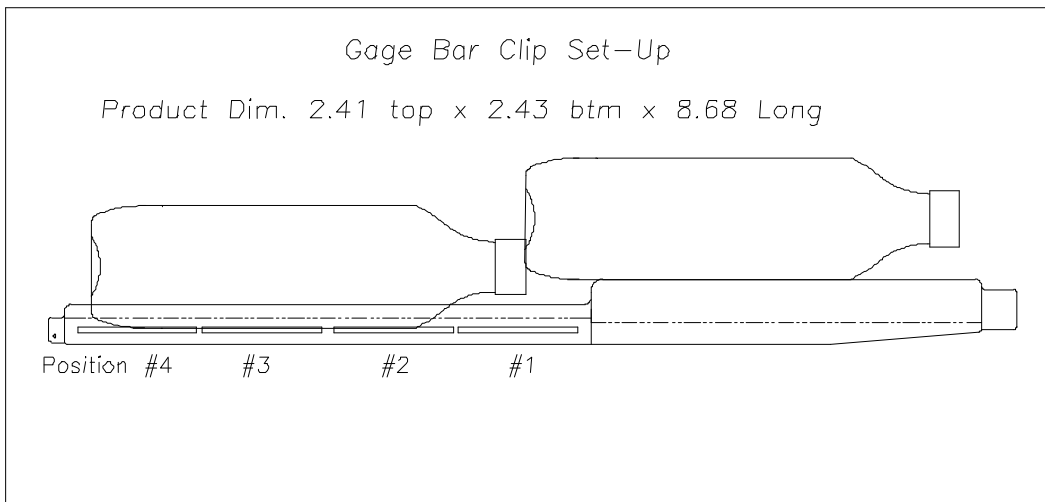

5. SET UP GUIDE.

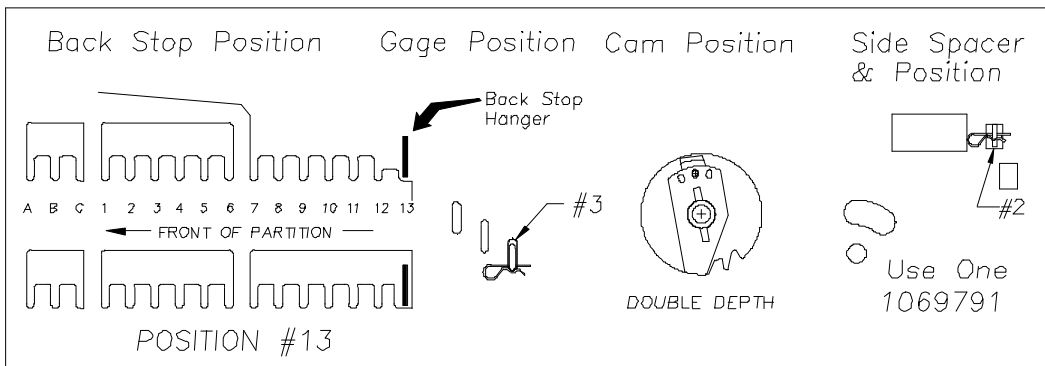

6. SOLD-OUT LEVER TO BE SHORT STYLE WITH FRONT SPACER. SPRING TO BE LOCATED ON THE RIGHT SIDE (LOW PRESSURE SETTING).

POWERADE (ATLANTA) HORIZONTAL LOGO TOP 20 OZ P.E.T. BOTTLE



UNIVENDOR-2 PRODUCT SET-UP GUIDE

11/25/96

REV. 1/23/97

1. PRODUCT

2.905 ±.080 x 7.693 ±.060 Long

2. PRODUCT CAPACITY

28 PER COLUMN - 72", 34 PER COLUMN - 79"

3. SET UP GUIDE

CAM POSITION	BACK SPACER	GAGE BAR	Sold out Lever	SIDE SHIM	GAGE BAR CLIP Part No.	Position
2	10	1	389242 SHORT	*TWO 1066821	1066112-1 1066104	1 2

4. GAGE BAR CLIP SET UP.

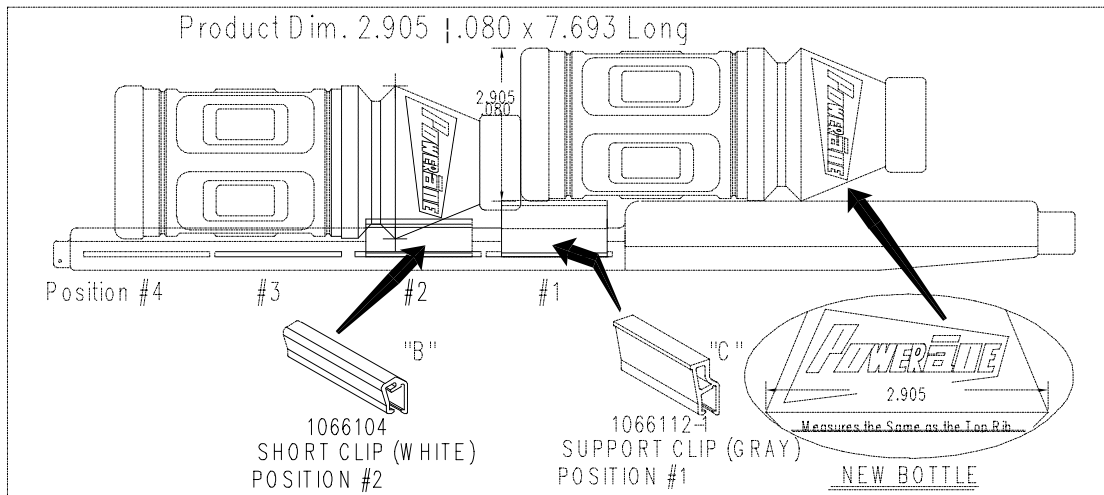

5. SET UP GUIDE.

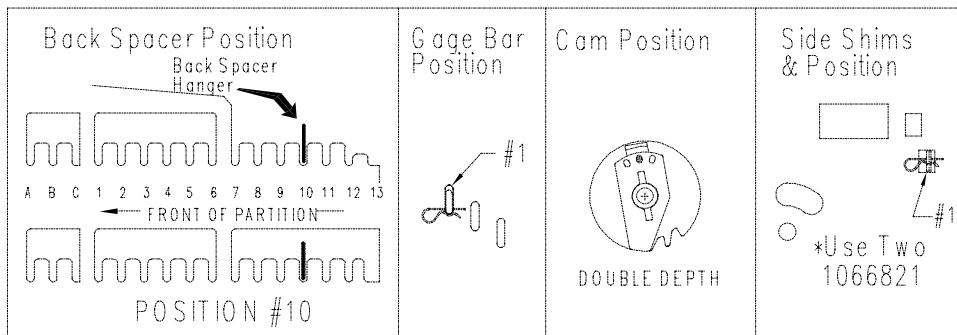

Note: *Due to the variance of diameter of the product from the PET Mfg. two flat shims will be required to properly vend 20oz. Powerade. If product exceeds the dimension of 2.905 +.080 remove shims accordingly.

6. SOLD-OUT LEVER TO BE SHORT STYLE WITH FRONT SPACER. SPRING TO BE LOCATED ON THE RIGHT SIDE (LOW PRESSURE SETTING).

7. FOR OTHER PRODUCT SET UP GUIDES CONTACT THE VENDO COMPANY.

***POWERADE (ATLANTA) HORIZONTAL LOGO
TOP 20 OZ P.E.T. BOTTLE***

TEL: (209) 439-1770 FAX: (209) 439-2083.

1. PRODUCT

20 OZ. POWERADE SLICK NECK WITH STD CAP - 2.90 Top x 2.90 Btm x 7.67 Long

2. PRODUCT CAPACITY

28 PER COLUMN - 72", 34 PER COLUMN - 79"

3. SET UP GUIDE UNIVENDOR-2

Product	CAM POSITION	BACK SPACER	GAGE BAR	Sold out Lever	SIDE SHIM	GAGE BAR CLIP	
						Part No.	Position
20 oz Powerade	2	9	1	389242 SHORT	*TWO	1066112-1	1
					1074465	1066104	2

Note: To properly vend 20oz Powerade. The Univendor-2 must have the columns setup correctly.

4. GAGE BAR CLIP SET UP.

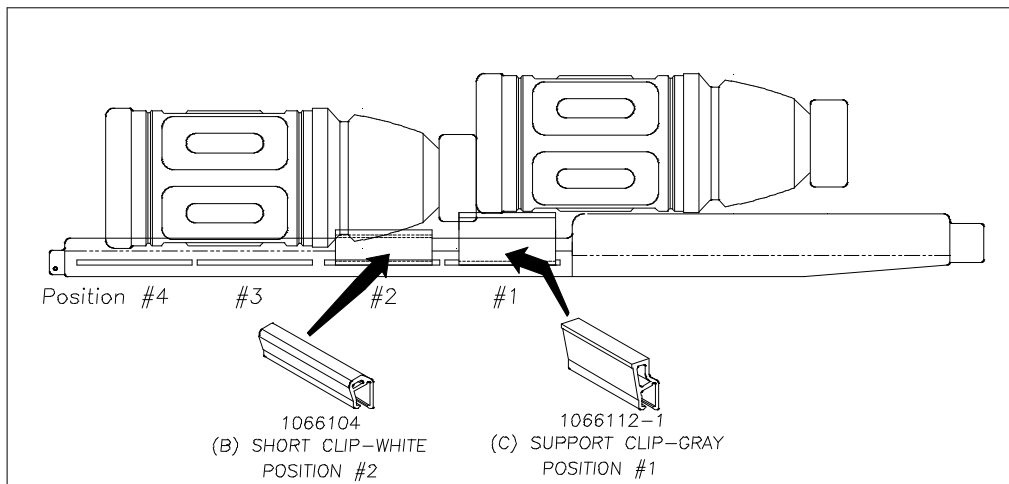

5. SET UP GUIDE.

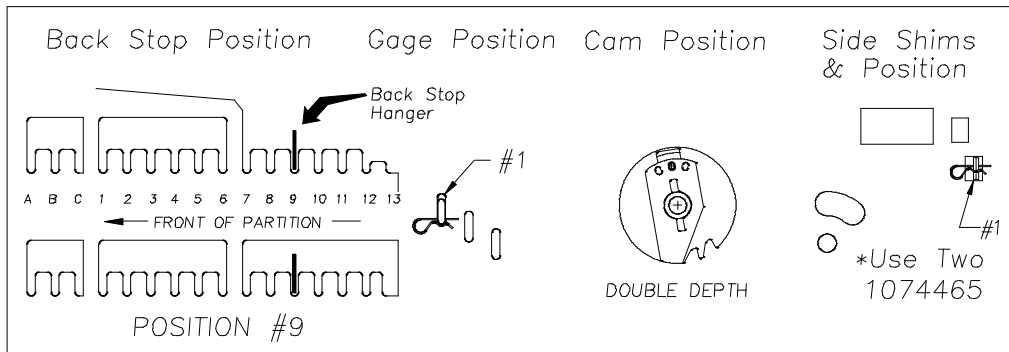

Note: *Due to the variance of diameter of the product from the PET Mfg. two flat shims will be required to properly vend 20oz. Powerade. If product exceeds the dimension of 2.905 +.080 remove shims accordingly.

**6. SOLD-OUT LEVER TO BE SHORT STYLE WITH FRONT SPACER.
SPRING TO BE LOCATED ON THE RIGHT SIDE (LOW PRESSURE SETTING).**

**7. FOR OTHER PRODUCT SET UP GUIDES CONTACT THE VENDO COMPANY.
TEL: (209) 439-1770 FAX: (209) 439-2083.**

POWERADE (GENERAL) 20 OZ. P.E.T. BOTTLE



UNIVENDOR-2 POWERADE PRODUCT TYPE VARIATIONS

5/22/96

REV. 1/23/97

1. **PRODUCT**
20 OZ. POWERADE PET
2. **PRODUCT CAPACITY**
28 PER COLUMN - 72", 34 PER COLUMN - 79"
3. **PRODUCT TYPES**

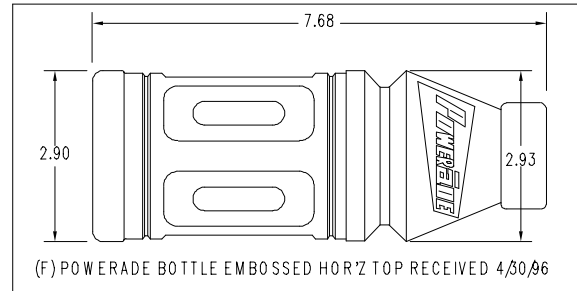
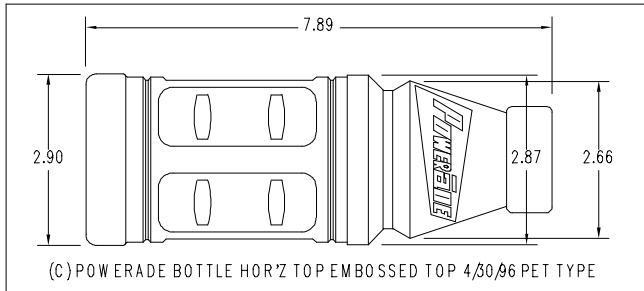
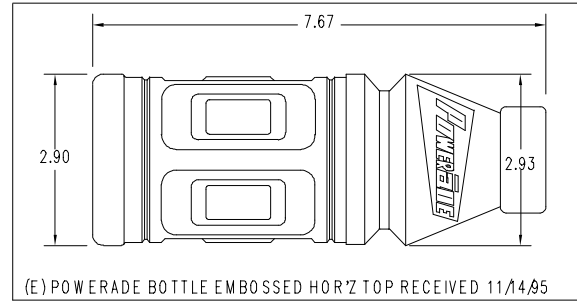
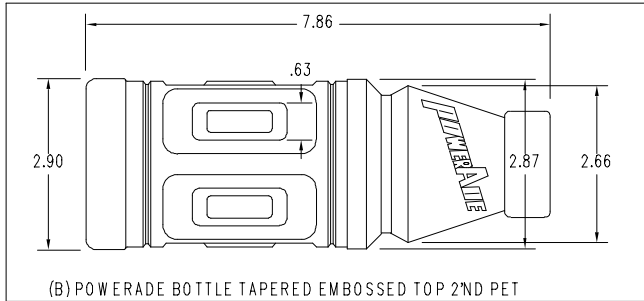
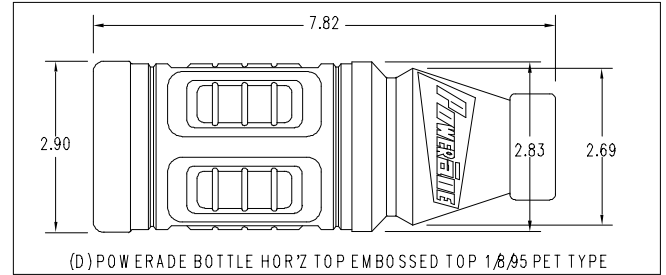
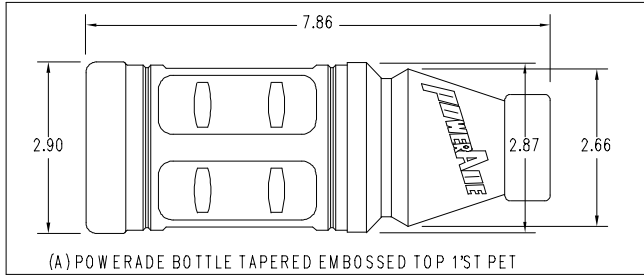

4. SET UP GUIDE FOR A - D POWERADE PRODUCTS ON UNIVENDOR-2

CAM POSITION	BACK SPACER	GAGE BAR	Sold out Lever	SIDE SHIM	GAGE BAR CLIP	
					Part No.	Position
2	9	1	389242 SHORT	TWO	1066112-1	1
				1066821	1066104	2

5. SET UP GUIDE FOR E - F POWERADE PRODUCTS ON UNIVENDOR-2

CAM POSITION	BACK SPACER	GAGE BAR	Sold out Lever	SIDE SHIM	GAGE BAR CLIP	
					Part No.	Position
2	10	1	389242 SHORT	NONE	1066112-1	1
					1066104	2

6. **FOR OTHER PRODUCT SET UP GUIDES CONTACT THE VENDO COMPANY.**
TEL: (209) 439-1770 FAX: (209) 439-2083.